

# Synthesis of Novel Molybdenum(II) Carbide Complexes: A Technical Guide

**Author:** BenchChem Technical Support Team. **Date:** April 2026

## Compound of Interest

Compound Name:	Carbanide;molybdenum(2+)
CAS No.:	109585-24-2
Cat. No.:	B15424929

[Get Quote](#)

For Researchers, Scientists, and Drug Development Professionals

This technical guide provides an in-depth overview of the synthesis, characterization, and experimental protocols for novel molybdenum(II) carbide complexes. The information is tailored for researchers and professionals in chemistry and drug development, with a focus on clear data presentation and reproducible methodologies.

## Introduction to Molybdenum(II) Carbide Complexes

Molybdenum carbide complexes, particularly those featuring a terminal carbide ligand ( $\text{Mo}\equiv\text{C}$ ), are a class of organometallic compounds with significant potential in catalysis and synthetic chemistry.[1][2] The Mo(II) oxidation state in these complexes allows for unique electronic properties and reactivity. The synthesis of these complexes is often challenging, requiring careful control of reaction conditions and the use of specialized ancillary ligands to stabilize the reactive carbide moiety.[1][2] This guide will focus on the synthesis and characterization of terminal molybdenum(II) carbide complexes, which are valuable as synthons for more complex molecules and materials.[3]

## Synthetic Methodologies

The primary route to terminal molybdenum(II) carbide complexes involves the reductive cleavage of a carbon-oxygen bond in a coordinated carbon monoxide (CO) ligand. This transformation is typically achieved using strong reducing agents in the presence of a suitable ancillary ligand system that can support the resulting low-valent molybdenum carbide fragment.

A key example is the synthesis of the terminal carbide complex  $[P_2Mo(\equiv C)(CO)]$ , where  $P_2$  represents a terphenyl diphosphine ligand.[1] The synthesis proceeds through a multi-step process involving the reduction of a Mo(II) precursor in the presence of CO.

## Synthesis of a Key Molybdenum(II) Carbide Precursor

A common precursor for the synthesis of terminal molybdenum(II) carbide complexes is a molybdenum dicarbonyl species supported by a pincer-type ligand. The synthesis of such a precursor is outlined below.

### Experimental Protocol: Synthesis of $P_2Mo(CO)_2$

This protocol describes the synthesis of a key precursor for the generation of the terminal carbide complex.

- Materials: Molybdenum(II) bromide dicarbonyl  $[MoBr_2(CO)_4]$ , terphenyl diphosphine ligand ( $P_2$ ), potassium graphite (KC8), tetrahydrofuran (THF), diethyl ether.
- Procedure:
  - A solution of  $[MoBr_2(CO)_4]$  in THF is treated with one equivalent of the terphenyl diphosphine ligand ( $P_2$ ) at room temperature.
  - The reaction mixture is stirred for 12 hours, during which time the color changes, indicating the formation of the  $P_2MoBr_2(CO)_2$  complex.
  - The resulting solution is then cooled to  $-35\text{ }^\circ\text{C}$  and two equivalents of potassium graphite (KC8) are added as a reducing agent.
  - The mixture is stirred for an additional 12 hours at  $-35\text{ }^\circ\text{C}$ .

- The solvent is removed under vacuum, and the residue is extracted with diethyl ether.
- The ether extract is filtered and concentrated to yield the desired  $P_2Mo(CO)_2$  product as a solid.

## Synthesis of Terminal Molybdenum(II) Carbide Complexes

The terminal carbide complex  $[K][P_2Mo(\equiv C)(CO)]$  is synthesized from the  $P_2Mo(CO)_2$  precursor through a carefully controlled reduction and CO cleavage process.

Experimental Protocol: Synthesis of  $[K][P_2Mo(\equiv C)(CO)]$

- Materials:  $P_2Mo(CO)_2$ , potassium graphite (KC8), 18-crown-6, tetrahydrofuran (THF), pentane.
- Procedure:
  - A solution of  $P_2Mo(CO)_2$  in THF is cooled to  $-35\text{ }^\circ\text{C}$ .
  - One equivalent of potassium graphite (KC8) and one equivalent of 18-crown-6 are added to the solution.
  - The reaction mixture is stirred for 12 hours at  $-35\text{ }^\circ\text{C}$ , during which time the solution color changes, indicating the formation of the carbide complex.
  - The solvent is removed under vacuum, and the residue is washed with pentane to remove any unreacted starting materials.
  - The resulting solid is dried under vacuum to yield  $[K][P_2Mo(\equiv C)(CO)]$  as a highly air- and moisture-sensitive solid.

## Quantitative Data

The synthesized molybdenum(II) carbide complexes have been characterized by various spectroscopic and analytical techniques. The key quantitative data are summarized in the tables below.

Table 1: Selected Spectroscopic Data for Molybdenum(II) Carbide Complexes

Complex	IR $\nu(\text{CO})$ ( $\text{cm}^{-1}$ )	$^{13}\text{C}$ NMR $\delta(\text{Mo}\equiv\text{C})$ (ppm)
[K][P2Mo( $\equiv\text{C}$ )(CO)]	1751	330.5
[P2Mo( $\equiv\text{C}$ )(CO)][BArF4]	1851	350.2

Data sourced from reference[1].

Table 2: Selected Crystallographic Data for [K(18-crown-6)][P2Mo( $\equiv\text{C}$ )(CO)]

Parameter	Value
Crystal System	Monoclinic
Space Group	P2 <sub>1</sub> /n
a (Å)	15.123(4)
b (Å)	25.456(7)
c (Å)	18.987(5)
$\beta$ (°)	98.765(4)
V (Å <sup>3</sup> )	7214(3)
Mo $\equiv$ C Bond Length (Å)	1.75(1)

Data sourced from reference[1].

## Visualization of Synthetic Pathways

The following diagrams illustrate the key synthetic workflows described in this guide.

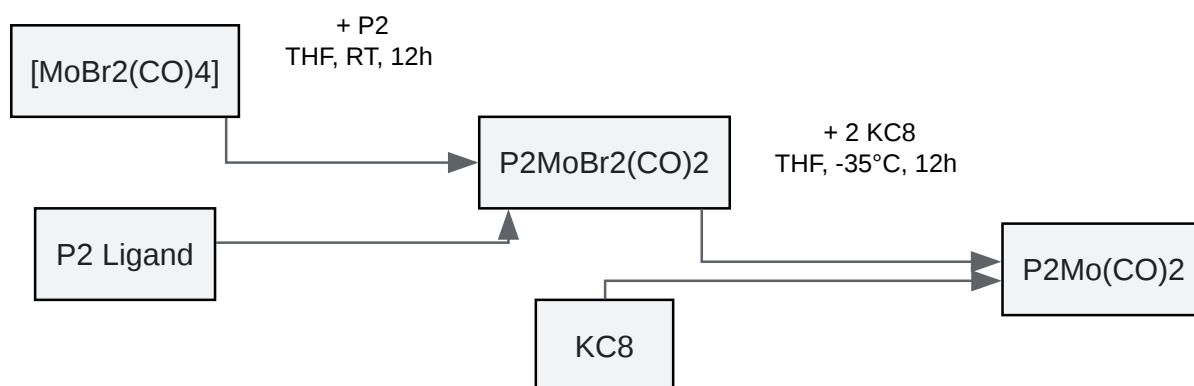

[Click to download full resolution via product page](#)

Caption: Synthesis of the  $P_2Mo(CO)_2$  precursor.

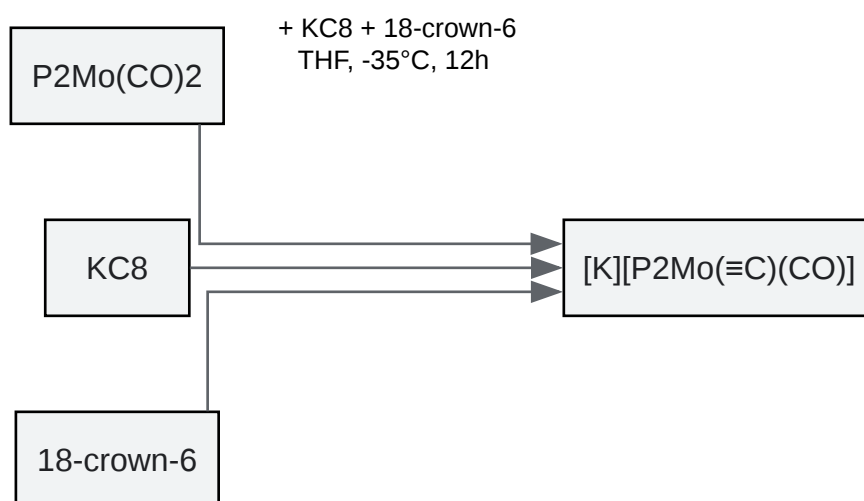

[Click to download full resolution via product page](#)

Caption: Synthesis of the terminal carbide complex.

## Conclusion

This guide has provided a detailed overview of the synthesis of novel molybdenum(II) carbide complexes, focusing on the preparation of the terminal carbide  $[K][P_2Mo(\equiv C)(CO)]$ . The experimental protocols and quantitative data presented herein are intended to serve as a valuable resource for researchers in the field. The synthetic methodologies described offer a foundation for the further exploration and development of new molybdenum carbide complexes with potential applications in catalysis and organic synthesis. The careful handling of these air-

and moisture-sensitive compounds is crucial for successful synthesis and subsequent reactivity studies.

### Need Custom Synthesis?

BenchChem offers custom synthesis for rare earth carbides and specific isotopic labeling.

Email: [info@benchchem.com](mailto:info@benchchem.com) or [Request Quote Online](#).

## References

- [1. pubs.acs.org \[pubs.acs.org\]](https://pubs.acs.org)
- [2. pubs.acs.org \[pubs.acs.org\]](https://pubs.acs.org)
- [3. Molybdenum–Iron–Sulfur Cluster with a Bridging Carbide Ligand as a Partial FeMoco Model: CO Activation, EPR Studies, and Bonding Insight - PMC \[pmc.ncbi.nlm.nih.gov\]](https://pubmed.ncbi.nlm.nih.gov/31111111/)
- To cite this document: BenchChem. [Synthesis of Novel Molybdenum(II) Carbide Complexes: A Technical Guide]. BenchChem, [2026]. [Online PDF]. Available at: [\[https://www.benchchem.com/product/b15424929/docs#synthesis-of-novel-molybdenum-ii-carbide-complexes-a-technical-guide\]](https://www.benchchem.com/product/b15424929/docs#synthesis-of-novel-molybdenum-ii-carbide-complexes-a-technical-guide)

---

### Disclaimer & Data Validity:

The information provided in this document is for Research Use Only (RUO) and is strictly not intended for diagnostic or therapeutic procedures. While BenchChem strives to provide accurate protocols, we make no warranties, express or implied, regarding the fitness of this product for every specific experimental setup.

**Technical Support:** The protocols provided are for reference purposes. Unsure if this reagent suits your experiment?

**Need Industrial/Bulk Grade?** [Request Custom Synthesis Quote](#)

# BenchChem

Our mission is to be the trusted global source of essential and advanced chemicals, empowering scientists and researchers to drive progress in science and industry.

## Contact

Address: 3281 E Guasti Rd

Ontario, CA 91761, United States

Phone: (601) 213-4426

Email: [info@benchchem.com](mailto:info@benchchem.com)

[Contact our Ph.D. Support Team for a compatibility check](#)