

# Technical Support Center: Enhancing the Long-Term Stability of Calcium Arsenate

**Author:** BenchChem Technical Support Team. **Date:** May 2026

## Compound of Interest

Compound Name: Calcium arsenate

CAS No.: 10103-62-5

Cat. No.: B154242

[Get Quote](#)

## Introduction

**Calcium arsenate** ( $\text{Ca}_3(\text{AsO}_4)_2$ ) is an inorganic compound that has seen historical use as a pesticide and herbicide.[1] In contemporary research and industrial applications, particularly within metallurgy and waste remediation, controlling its stability is paramount.[2][3] **Calcium arsenate** compounds are inherently unstable, especially with prolonged exposure to moisture and atmospheric carbon dioxide.[2] This guide provides researchers, scientists, and drug development professionals with in-depth technical support for enhancing the long-term stability of **calcium arsenate** in experimental and storage contexts. We will explore the mechanisms of degradation and provide actionable troubleshooting advice and protocols.

The primary challenge in maintaining the stability of **calcium arsenate** lies in its susceptibility to hydrolysis and reaction with atmospheric  $\text{CO}_2$ . These reactions can lead to the release of soluble, and therefore more mobile and potentially toxic, arsenic species.[2] Understanding the chemical principles that govern these degradation pathways is the first step toward effective stabilization.

## Troubleshooting Guide: Common Stability Issues

This section addresses specific issues you may encounter during your experiments, providing not just a solution but the scientific reasoning behind it.

## Issue 1: A white precipitate forms in my aqueous calcium arsenate solution, or the solution appears cloudy over time.

Q: Why is my **calcium arsenate** solution becoming heterogeneous?

A: This is often a sign of degradation, specifically hydrolysis or carbonation. **Calcium arsenate** has low solubility in water, but its stability is highly dependent on pH.[4][5] In neutral or acidic conditions, it can hydrolyze to form more soluble and phytotoxic arsenic acid. Furthermore, exposure to air allows atmospheric carbon dioxide to dissolve in the solution, forming carbonic acid. This lowers the pH and reacts with calcium ions to precipitate calcium carbonate (CaCO<sub>3</sub>), a white, insoluble solid. This reaction simultaneously releases arsenic into the solution, increasing its mobility.[2]

Causality Explained: The degradation is driven by two main chemical reactions:

- Hydrolysis:  $\text{Ca}_3(\text{AsO}_4)_2(\text{s}) + 6\text{H}_2\text{O}(\text{l}) \rightleftharpoons 3\text{Ca}^{2+}(\text{aq}) + 2\text{AsO}_4^{3-}(\text{aq}) + 6\text{H}_2\text{O}(\text{l}) \rightarrow 3\text{Ca}(\text{OH})_2(\text{aq}) + 2\text{H}_3\text{AsO}_4(\text{aq})$
- Carbonation:  $\text{Ca}_3(\text{AsO}_4)_2(\text{s}) + 3\text{CO}_2(\text{g}) + 3\text{H}_2\text{O}(\text{l}) \rightarrow 3\text{CaCO}_3(\text{s}) + 2\text{H}_3\text{AsO}_4(\text{aq})$

Solutions & Preventative Measures:

- pH Control: Maintain a high pH (alkaline) environment, ideally above pH 11.[4] The lowest equilibrium concentrations of arsenic, indicating highest stability, are observed at high pH.[4] You can achieve this by preparing your solutions with a buffer or by adding a base like calcium hydroxide (lime).
- Inert Atmosphere: To prevent carbonation, handle and store solutions under an inert atmosphere, such as nitrogen or argon. This minimizes contact with atmospheric CO<sub>2</sub>. [2]
- Excess Calcium Ions: The presence of excess calcium ions in the solution can suppress the dissolution of **calcium arsenate** through the common ion effect.[2] Preparing solutions with a

saturated lime (calcium hydroxide) solution can provide both a high pH and an excess of  $\text{Ca}^{2+}$  ions.[2]

## Issue 2: Analytical quantification shows a decrease in the concentration of solid calcium arsenate and an increase in soluble arsenic over time.

Q: What is causing the active compound to leach into the supernatant?

A: This indicates that the equilibrium of the dissolution reaction is shifting to favor the formation of soluble arsenic species. The primary factors influencing this are pH, temperature, and the presence of competing ions. As discussed, lower pH significantly increases solubility.[4] Elevated temperatures can also increase the rate of dissolution and degradation.

Causality Explained: The stability of various **calcium arsenate** hydrates is delicately balanced. For example, different hydrated forms like  $\text{Ca}_4(\text{OH})_2(\text{AsO}_4)_2 \cdot 4\text{H}_2\text{O}$  and  $\text{Ca}_5(\text{AsO}_4)_3\text{OH}$  (arsenate apatite) exhibit their lowest solubility and greatest stability at high pH levels, often above 12.[4] A decrease in pH below this optimal range will invariably lead to increased dissolution.

Solutions & Preventative Measures:

- **Strict pH Monitoring:** Regularly monitor and adjust the pH of your solutions and slurries to maintain highly alkaline conditions.
- **Temperature Control:** Store stock solutions and experimental setups at controlled, cool temperatures (e.g., 4°C) unless the protocol specifies otherwise. Avoid exposure to heat sources.
- **Solid-State Storage:** For long-term storage, it is best to keep **calcium arsenate** as a dry, solid powder in a desiccated, airtight container to prevent interaction with moisture and  $\text{CO}_2$ .  
[2]

## Frequently Asked Questions (FAQs)

Q1: What is the ideal pH for storing **calcium arsenate** solutions to ensure maximum stability?

A1: The ideal pH is high, typically above 11 and preferably around 12.5.[4] Studies have shown that certain **calcium arsenate** hydrates, such as  $\text{Ca}_4(\text{OH})_2(\text{AsO}_4)_2 \cdot 4\text{H}_2\text{O}$ , achieve minimum arsenic equilibrium concentrations (as low as 0.01 mg/L) at a pH near 12.5, indicating maximum stability.[4]

Q2: How does the presence of other ions, like phosphate, affect stability? A2: Phosphate ions can compete with arsenate ions. However, studies on the formation of solid solutions between arsenate apatite ( $\text{Ca}_5(\text{AsO}_4)_3\text{OH}$ ) and hydroxyapatite ( $\text{Ca}_5(\text{PO}_4)_3\text{OH}$ ) have shown that under ambient conditions, a stable solid solution does not readily form. Instead, the more stable arsenate apatite tends to form at the expense of the phosphate compound, suggesting that in some systems, the presence of phosphate may not necessarily destabilize the **calcium arsenate** solid.[4]

Q3: Can I stabilize **calcium arsenate** by co-precipitation with other metals? A3: Yes, this is a common strategy in waste remediation. Co-precipitation with ferric iron ( $\text{Fe}^{3+}$ ) to form iron arsenates like scorodite ( $\text{FeAsO}_4 \cdot 2\text{H}_2\text{O}$ ) is a widely accepted method for long-term arsenic stabilization.[3][6] Scorodite is significantly less soluble than **calcium arsenate**, especially under acidic to neutral conditions.[4] Recently, a novel method involves coating **calcium arsenate** particles with a layer of iron arsenate, which dramatically improves stability and resistance to leaching.[7]

Q4: What are the best analytical techniques to monitor the stability of my **calcium arsenate** samples? A4: A combination of techniques is recommended. To measure the concentration of soluble arsenic that has leached from the solid, use Inductively Coupled Plasma Mass Spectrometry (ICP-MS) or Atomic Absorption Spectrometry (AAS) for their high sensitivity.[8][9] To analyze the solid phase and identify any changes in its crystalline structure or the formation of degradation products (like calcium carbonate), use X-ray Diffraction (XRD).[2]

## Stabilization & Analysis Protocols

### Protocol 1: Preparation of a Stabilized Calcium Arsenate Slurry

This protocol describes how to prepare an aqueous slurry of **calcium arsenate** with enhanced stability for experimental use.

Objective: To create a homogeneous slurry of **calcium arsenate** that minimizes dissolution and degradation.

Materials:

- **Calcium arsenate** ( $\text{Ca}_3(\text{AsO}_4)_2$ ) powder
- Calcium hydroxide ( $\text{Ca}(\text{OH})_2$ )
- Deionized,  $\text{CO}_2$ -free water (prepare by boiling DI water for 30 minutes and cooling under an inert gas)
- pH meter and probe
- Magnetic stirrer and stir bar
- Airtight storage container
- Nitrogen or Argon gas source

Procedure:

- **Prepare Saturated Lime Solution:** Add an excess of calcium hydroxide to  $\text{CO}_2$ -free deionized water in a beaker. Stir vigorously for 1 hour to ensure saturation. Allow the undissolved solid to settle.
- **Decant Supernatant:** Carefully decant the clear supernatant. This is your saturated lime solution, which should have a pH of approximately 12.4.
- **Prepare Slurry:** In a new container, add the desired amount of **calcium arsenate** powder.
- **Add Lime Solution:** Slowly add the saturated lime solution to the **calcium arsenate** powder while stirring to achieve the target concentration.
- **Inert Gas Purge:** Purge the headspace of the container with nitrogen or argon gas for 5 minutes to displace air and  $\text{CO}_2$ .
- **Seal and Store:** Seal the container tightly. Store at a controlled cool temperature (e.g.,  $4^\circ\text{C}$ ).

- Validation: Before use, allow the slurry to settle, and measure the soluble arsenic concentration in the supernatant using ICP-MS to confirm low dissolution.

## Protocol 2: Accelerated Stability Testing using the Toxicity Characteristic Leaching Procedure (TCLP)

This protocol is a standard method to assess the stability of a solid material and its potential to leach hazardous components into the environment.[2]

Objective: To determine the stability of a **calcium arsenate** formulation by measuring the amount of arsenic leached under specified extraction conditions.

Materials:

- **Calcium arsenate** sample
- TCLP Extraction Fluid #1 (0.1 M acetic acid/sodium acetate buffer, pH 4.93 ± 0.05)
- Rotary agitation apparatus
- Filtration device (0.6 to 0.8 µm glass fiber filter)
- Collection vials
- ICP-MS or AAS for analysis

Procedure:

- Sample Preparation: Weigh 10 grams of your solid **calcium arsenate** sample.
- Extraction: Place the sample in an extraction vessel. Add 200 mL of TCLP Extraction Fluid #1.
- Agitation: Seal the vessel and secure it in the rotary agitation apparatus. Rotate at 30 ± 2 rpm for 18 ± 2 hours at room temperature (23 ± 2°C).
- Filtration: After agitation, filter the mixture through a new glass fiber filter to separate the solid from the liquid extract (leachate).

- Analysis: Analyze the leachate for arsenic concentration using ICP-MS or AAS.
- Interpretation: A lower concentration of arsenic in the leachate indicates higher stability of the original sample. Unstabilized **calcium arsenates** can yield very high TCLP leachate concentrations (e.g., >300 mg/L), while effectively stabilized forms will be significantly lower. [7]

## Data Summary

The stability of **calcium arsenate** is critically dependent on pH. The following table summarizes the relationship between pH and the equilibrium concentration of dissolved arsenic for different **calcium arsenate** compounds, demonstrating the importance of maintaining high pH.

Calcium Arsenate Compound	pH	Equilibrium Arsenic Conc. (mg/L)	Source
$\text{Ca}_4(\text{OH})_2(\text{AsO}_4)_2 \cdot 4\text{H}_2\text{O}$	~12.5	0.01	[4]
$\text{Ca}_4(\text{OH})_2(\text{AsO}_4)_2 \cdot 4\text{H}_2\text{O}$	Stable Range	< 0.5	[4]
$\text{Ca}_5(\text{AsO}_4)_3\text{OH}$ (Arsenate Apatite)	~12.5	< 0.5	[4]
$\text{Ca}_3(\text{AsO}_4)_2 \cdot x\text{H}_2\text{O}$	Not specified	High	[2]

## Visual Diagrams

### Degradation Pathways of Calcium Arsenate

The following diagram illustrates the primary chemical pathways through which **calcium arsenate** degrades in the presence of water and carbon dioxide.

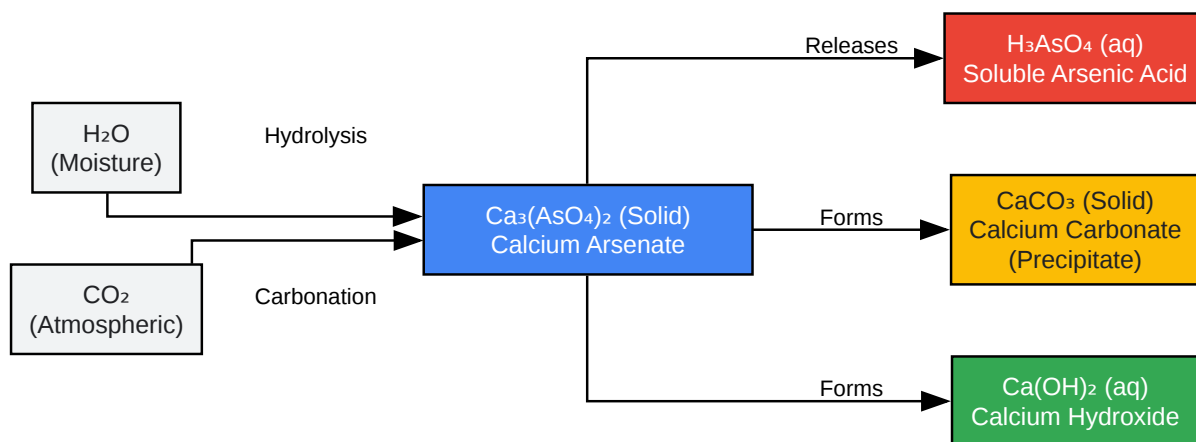

[Click to download full resolution via product page](#)

Caption: Key degradation pathways for **calcium arsenate**.

## Experimental Workflow for Stability Assessment

This diagram outlines the key steps in assessing the stability of a **calcium arsenate** sample, from preparation to final analysis.

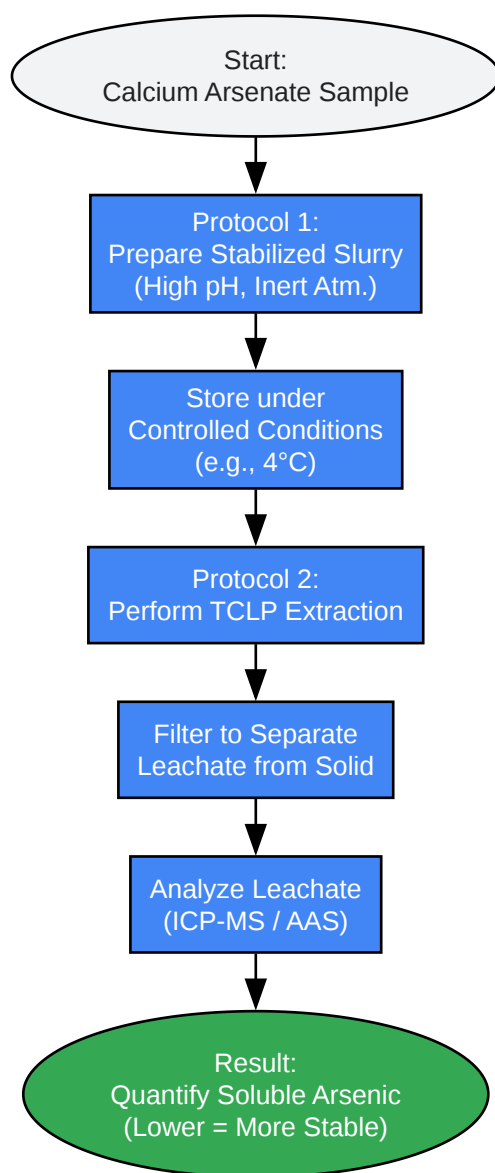

[Click to download full resolution via product page](#)

Caption: Workflow for **calcium arsenate** stability testing.

## References

- Botnen, A., et al. (1999). Arsenic Immobilization by **Calcium Arsenate** Formation. *Environmental Science & Technology*, 33(21), 3767-3772. [[Link](#)]
- AERU, University of Hertfordshire. (n.d.). **Calcium arsenate**. [[Link](#)]

- Swash, P. M., & Monhemius, A. J. (n.d.). Characteristics of **calcium arsenate** compounds relevant to disposal of arsenic from industrial processes. ResearchGate. [[Link](#)]
- National Center for Biotechnology Information. (n.d.). **Calcium arsenate**. PubChem. [[Link](#)]
- New Jersey Department of Health. (2002). Hazardous Substance Fact Sheet: Calcium Arsenite. [[Link](#)]
- Zhu, Y. N., et al. (2006). Solubility and Stability of **Calcium Arsenates** at 25°C. Water, Air, and Soil Pollution, 169(1-4), 221-238. [[Link](#)]
- Wikipedia. (n.d.). **Calcium arsenate**. [[Link](#)]
- Li, J., et al. (2023). Divergent Aging Mechanisms of Calcium Arsenic Residue under Dry-Wet and Freeze-Thaw Cycles: Toxic Metal Mobility, Multiscale Physicochemical Characterization, and Escalated Ecological Risks. Environmental Science and Pollution Research, 30(58), 1-15. [[Link](#)]
- Tanaka, Y., Matsuhashi, K., & Ogra, Y. (2025). Analytical techniques for arsenic speciation. Analytical Sciences. [[Link](#)]
- Wang, Q., Li, J., & Wei, Y. (2016). Stabilization of arsenic in the mining and metallurgical industries – a review. ResearchGate. [[Link](#)]
- Zhang, Y., et al. (2020). Alternative Method for the Treatment of Hydrometallurgical Arsenic–Calcium Residues: The Immobilization of Arsenic as Scorodite. ACS Omega, 5(22), 13036-13044. [[Link](#)]
- Tanaka, Y., Matsuhashi, K., & Ogra, Y. (2025). Analytical techniques for arsenic speciation. ResearchGate. [[Link](#)]
- Ramos-Arroyo, Y. R., & Siebe, C. (2021). Stabilization and encapsulation of arsenic-/antimony-bearing mine waste: Overview and outlook of existing techniques. Taylor & Francis Online. [[Link](#)]
- Tanaka, Y., Matsuhashi, K., & Ogra, Y. (2025). Analytical techniques for arsenic speciation. SpringerLink. [[Link](#)]

- Zhang, Y., et al. (2020). The synthesis of **calcium arsenate**@iron arsenate coating materials and their application for arsenic-containing wastewater treatment. RSC Advances, 10(2), 949-957. [[Link](#)]
- Nanor, J. B. (2000). Removal and stabilization of arsenic. Globe Thesis. [[Link](#)]
- Shakoor, M. B., & Niazi, N. K. (2017). Physical, Chemical, and Biological Methods for the Removal of Arsenic Compounds. BioMed Research International, 2017, 6032392. [[Link](#)]

### Need Custom Synthesis?

BenchChem offers custom synthesis for rare earth carbides and specific isotopic labeling.

Email: [info@benchchem.com](mailto:info@benchchem.com) or [Request Quote Online](#).

## Sources

- [1. Calcium arsenate - Wikipedia \[en.wikipedia.org\]](#)
- [2. researchgate.net \[researchgate.net\]](#)
- [3. researchgate.net \[researchgate.net\]](#)
- [4. pubs.acs.org \[pubs.acs.org\]](#)
- [5. Calcium arsenate \[sitem.herts.ac.uk\]](#)
- [6. Physical, Chemical, and Biological Methods for the Removal of Arsenic Compounds - PMC \[pmc.ncbi.nlm.nih.gov\]](#)
- [7. The synthesis of calcium arsenate@iron arsenate coating materials and their application for arsenic-containing wastewater treatment - PMC \[pmc.ncbi.nlm.nih.gov\]](#)
- [8. Analytical techniques for arsenic speciation - PMC \[pmc.ncbi.nlm.nih.gov\]](#)
- [9. d-nb.info \[d-nb.info\]](#)
- To cite this document: BenchChem. [Technical Support Center: Enhancing the Long-Term Stability of Calcium Arsenate]. BenchChem, [2026]. [Online PDF]. Available at: [<https://www.benchchem.com/product/b154242/docs#technical-support-center-enhancing-the-long-term-stability-of-calcium-arsenate>]

---

### Disclaimer & Data Validity:

The information provided in this document is for Research Use Only (RUO) and is strictly not intended for diagnostic or therapeutic procedures. While BenchChem strives to provide accurate protocols, we make no warranties, express or implied, regarding the fitness of this product for every specific experimental setup.

**Technical Support:** The protocols provided are for reference purposes. Unsure if this reagent suits your experiment?

**Need Industrial/Bulk Grade?** [Request Custom Synthesis Quote](#)

## BenchChem

Our mission is to be the trusted global source of essential and advanced chemicals, empowering scientists and researchers to drive progress in science and industry.

### Contact

Address: 3281 E Guasti Rd  
Ontario, CA 91761, United States  
Phone: (601) 213-4426  
Email: [info@benchchem.com](mailto:info@benchchem.com)

[Contact our Ph.D. Support Team for a compatibility check](#)