

Application Note: Elucidating the Mass Spectrometry Fragmentation Pattern of Methyl 2-Propylpentanoate

Author: BenchChem Technical Support Team. **Date:** May 2026

Compound of Interest

Compound Name: *Methyl 2-propylpentanoate*

CAS No.: 22632-59-3

Cat. No.: B154064

[Get Quote](#)

Introduction

Methyl 2-propylpentanoate is a branched-chain fatty acid methyl ester (FAME) that serves as a valuable model compound in various research areas, including metabolomics, flavor and fragrance analysis, and as a biomarker for certain metabolic disorders. Understanding its behavior under electron ionization (EI) mass spectrometry is crucial for its unambiguous identification and quantification in complex matrices. This application note provides a detailed guide to the fragmentation pattern of **methyl 2-propylpentanoate**, explaining the underlying mechanistic principles and offering a validated protocol for its analysis by gas chromatography-mass spectrometry (GC-MS).

The structural elucidation of organic molecules by mass spectrometry relies on the predictable fragmentation of the molecular ion. For esters like **methyl 2-propylpentanoate**, characteristic fragmentation pathways, including α -cleavage and McLafferty rearrangement, provide a structural fingerprint. This guide will dissect these pathways to build a comprehensive understanding of the resulting mass spectrum.

Core Principles of Ester Fragmentation in EI-MS

Upon electron ionization, **methyl 2-propylpentanoate** loses an electron to form a molecular ion ($M^{\bullet+}$). The charge is typically localized on the oxygen atom of the carbonyl group, which directs the subsequent fragmentation. The molecular weight of **methyl 2-propylpentanoate** ($C_9H_{18}O_2$) is 158.24 g/mol, and its molecular ion will be observed at an m/z of 158, although it may be of low abundance due to the facile fragmentation of esters.^[1]

Two primary fragmentation mechanisms govern the breakdown of the **methyl 2-propylpentanoate** molecular ion:

- α -Cleavage: This involves the cleavage of the C-C bond adjacent to the carbonyl group. This is a highly favored process as it leads to the formation of a resonance-stabilized acylium ion.^[1]
- McLafferty Rearrangement: This is a characteristic fragmentation of carbonyl compounds that possess a γ -hydrogen. It involves the transfer of a hydrogen atom from the γ -carbon to the carbonyl oxygen via a six-membered transition state, followed by the cleavage of the β -C-C bond.^[1]

Predicted Fragmentation Pattern of Methyl 2-Propylpentanoate

Based on these established principles and analysis of structurally similar compounds like methyl 2-methylpentanoate, the following key fragment ions are predicted for **methyl 2-propylpentanoate**:

m/z	Proposed Ion Structure	Fragmentation Pathway	Significance
158	$[\text{C}_9\text{H}_{18}\text{O}_2]^{\bullet+}$	Molecular Ion	Confirms molecular weight.
127	$[\text{M} - \text{OCH}_3]^+$	α -Cleavage	Loss of the methoxy radical.
115	$[\text{M} - \text{C}_3\text{H}_7]^+$	α -Cleavage	Loss of a propyl radical from the α -position.
101	$[\text{CH}(\text{C}_3\text{H}_7)\text{COOCH}_3]^{\bullet+}$	McLafferty Rearrangement	Loss of propene (C_3H_6).
88	$[\text{CH}_2=\text{C}(\text{OH})\text{OCH}_3]^{\bullet+}$	McLafferty Rearrangement	Characteristic for methyl esters with a γ -hydrogen.
74	$[\text{CH}_3\text{OC}(\text{OH})=\text{CH}_2]^{\bullet+}$	McLafferty Rearrangement	A common fragment for many fatty acid methyl esters.
59	$[\text{COOCH}_3]^+$	α -Cleavage	Methoxycarbonyl cation.
43	$[\text{C}_3\text{H}_7]^+$	Alkyl fragment	Propyl cation.

Visualizing the Fragmentation Pathways

The primary fragmentation pathways of **methyl 2-propylpentanoate** can be visualized to better understand the origin of the key fragment ions.

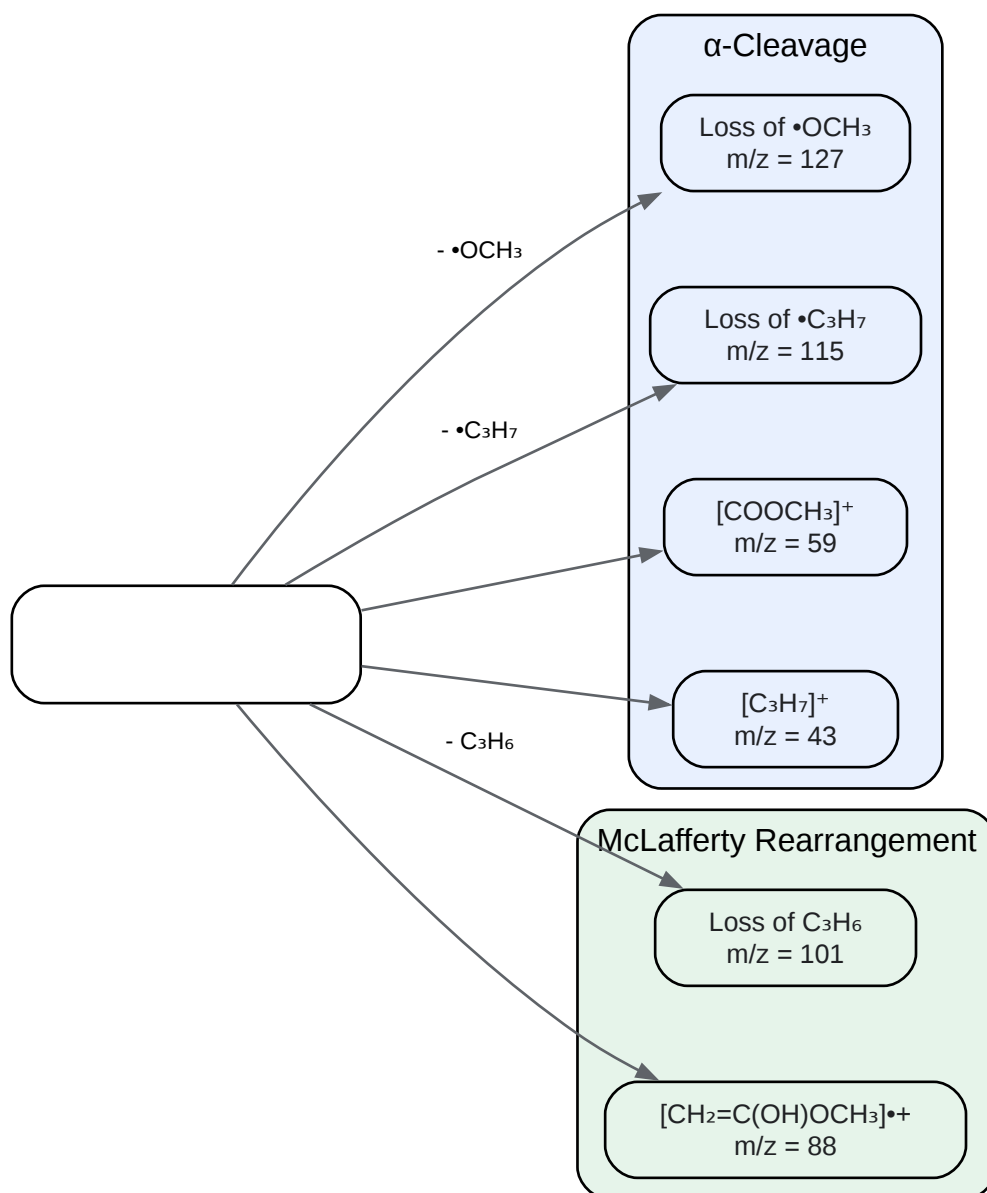

[Click to download full resolution via product page](#)

Need Custom Synthesis?

BenchChem offers custom synthesis for rare earth carbides and specific isotopic labeling.

Email: info@benchchem.com or [Request Quote Online](#).

Sources

- [1. chem.libretexts.org \[chem.libretexts.org\]](https://chem.libretexts.org)
- To cite this document: BenchChem. [Application Note: Elucidating the Mass Spectrometry Fragmentation Pattern of Methyl 2-Propylpentanoate]. BenchChem, [2026]. [Online PDF]. Available at: [<https://www.benchchem.com/product/b154064/docs#application-note-elucidating-the-mass-spectrometry-fragmentation-pattern-of-methyl-2-propylpentanoate>]

Disclaimer & Data Validity:

The information provided in this document is for Research Use Only (RUO) and is strictly not intended for diagnostic or therapeutic procedures. While BenchChem strives to provide accurate protocols, we make no warranties, express or implied, regarding the fitness of this product for every specific experimental setup.

Technical Support: The protocols provided are for reference purposes. Unsure if this reagent suits your experiment?

Need Industrial/Bulk Grade? [Request Custom Synthesis Quote](#)

BenchChem

Our mission is to be the trusted global source of essential and advanced chemicals, empowering scientists and researchers to drive progress in science and industry.

Contact

Address: 3281 E Guasti Rd
Ontario, CA 91761, United States
Phone: (601) 213-4426
Email: info@benchchem.com

[Contact our Ph.D. Support Team for a compatibility check](#)