

# Technical Support Center: Optimizing PROTAC Ternary Complex Formation

**Author:** BenchChem Technical Support Team. **Date:** April 2026

## Compound of Interest

Compound Name: Thalidomide-PEG5-NH2

Cat. No.: B11935376

[Get Quote](#)

Welcome to the technical support center for researchers, scientists, and drug development professionals working with Proteolysis Targeting Chimeras (PROTACs). This resource provides in-depth troubleshooting guides and frequently asked questions (FAQs) to address common challenges encountered during the optimization of PROTAC ternary complex formation, a critical step for successful targeted protein degradation.

## Frequently Asked Questions (FAQs)

Q1: What is a PROTAC ternary complex and why is its formation critical?

A PROTAC (Proteolysis Targeting Chimera) is a heterobifunctional molecule designed to eliminate specific proteins from within a cell. It consists of two distinct ligands connected by a chemical linker: one ligand binds to the target protein of interest (POI), and the other recruits an E3 ubiquitin ligase. The critical step in a PROTAC's mechanism of action is the formation of a ternary complex, where the PROTAC simultaneously binds to both the POI and the E3 ligase, bringing them into close proximity. This proximity facilitates the transfer of ubiquitin from the E3 ligase to the POI, marking the POI for degradation by the cell's proteasome.<sup>[1][2]</sup> Therefore, the stability and conformation of this ternary complex are paramount for efficient and selective protein degradation.

Q2: What is the "hook effect" in PROTAC experiments?

The "hook effect" is a phenomenon observed in PROTAC dose-response experiments where, at high concentrations, the degradation of the target protein paradoxically decreases.<sup>[2][3][4]</sup> This results in a bell-shaped dose-response curve. The effect is caused by the formation of unproductive binary complexes (PROTAC-target or PROTAC-E3 ligase) at excessive PROTAC concentrations, which compete with the formation of the productive ternary complex. Recognizing and mitigating the hook effect is crucial for accurately determining a PROTAC's potency (DC50) and efficacy (Dmax).

Q3: What is "cooperativity" in the context of ternary complex formation?

Cooperativity ( $\alpha$ ,  $\alpha$ ) is a measure of how the binding of one protein partner (either the target protein or the E3 ligase) to the PROTAC influences the binding of the other.

- Positive cooperativity ( $\alpha > 1$ ): The formation of a binary complex with one protein increases the PROTAC's affinity for the other protein, thus stabilizing the ternary complex.
- Negative cooperativity ( $\alpha < 1$ ): The formation of a binary complex with one protein decreases the PROTAC's affinity for the other.
- No cooperativity ( $\alpha = 1$ ): The binding events are independent.

High positive cooperativity is often a desirable feature in PROTACs as it can lead to more stable and long-lived ternary complexes, which in turn can result in more efficient protein degradation and can help mitigate the hook effect.

Q4: How does the choice of E3 ligase (e.g., VHL vs. CRBN) impact ternary complex formation and degradation?

The two most commonly used E3 ligases in PROTAC design are von Hippel-Lindau (VHL) and Cereblon (CRBN). The choice between them can significantly impact a PROTAC's performance. Factors to consider include:

- Tissue and tumor expression levels: VHL and CRBN expression can vary across different cell lines and tissues. For instance, VHL-based PROTACs may have broader utility as CRBN is sometimes found to be inactivated or expressed at low levels in certain cancer cell lines.

- Subcellular localization: CRBN is primarily nuclear, while VHL is found in both the cytoplasm and the nucleus, which can influence the degradation of targets in different cellular compartments.
- Ternary complex conformation: Different E3 ligases can induce distinct ternary complex structures, leading to variations in degradation efficiency and selectivity.
- Intrinsic properties: CRBN complexes may have faster turnover rates, which could be advantageous for rapidly dividing cells, whereas VHL forms more stable complexes, potentially better for more stable target proteins.

Q5: What is the role of the linker in PROTAC design?

The linker is not just a passive connector; it plays a crucial role in determining the efficacy of a PROTAC. Its length, composition, and attachment points dictate the geometry of the ternary complex. An optimal linker facilitates a productive orientation of the target protein and the E3 ligase, leading to efficient ubiquitination. An improperly designed linker can cause steric hindrance or an unfavorable conformation, thereby reducing degradation efficiency.

## Troubleshooting Guide

### Problem 1: Low or No Target Degradation

This is one of the most common challenges in PROTAC development. A systematic approach is necessary to pinpoint the issue.

Possible Cause	Troubleshooting Step & Rationale	Recommended Experiment(s)
Poor target engagement	Verify that the PROTAC is binding to the target protein in a cellular context. A lack of binding is a fundamental reason for inactivity.	Cellular Thermal Shift Assay (CETSA): A shift in the thermal stability of the target protein upon PROTAC treatment indicates direct engagement.
Inefficient ternary complex formation	Confirm that the PROTAC can successfully bring together the target protein and the E3 ligase. The inability to form a stable ternary complex is a major hurdle.	Co-immunoprecipitation (Co-IP): Pulldown of the E3 ligase should result in the co-precipitation of the target protein in a PROTAC-dependent manner. Proximity Ligation Assay (PLA): Provides in-situ evidence of ternary complex formation within cells.
Proteasome-independent degradation	Ensure that the observed protein loss is mediated by the proteasome. This confirms the intended mechanism of action.	Proteasome Inhibitor Co-treatment: Co-treat cells with the PROTAC and a proteasome inhibitor (e.g., MG132). A "rescue" of the target protein from degradation confirms proteasome dependency.
Suboptimal linker length or composition	The linker may be too short, causing steric hindrance, or too long, leading to an unproductive complex. Synthesize and test a library of PROTACs with varying linker lengths and compositions.	Dose-response Western Blot: Compare the DC50 and Dmax values of different linker variants to identify the optimal design.
Low E3 ligase expression in the cell line	The chosen E3 ligase may not be sufficiently expressed in the experimental cell model.	Western Blot or qPCR: Quantify the expression level of the recruited E3 ligase (e.g.,

---

VHL or CRBN) in the cell line being used.

---

Poor cell permeability

The PROTAC molecule may not be efficiently entering the cells. PROTACs are often large molecules that can have difficulty crossing the cell membrane.

Cellular uptake assays: Use methods like LC-MS/MS to quantify intracellular PROTAC concentrations.

---

## Problem 2: A Pronounced "Hook Effect" is Observed

A significant hook effect can limit the therapeutic window of a PROTAC.

Possible Cause	Troubleshooting Step & Rationale	Recommended Experiment(s)
Formation of unproductive binary complexes at high concentrations	This is the primary cause of the hook effect. The goal is to favor the formation of the ternary complex.	Detailed Dose-Response Analysis: Perform experiments with a wide and granular range of PROTAC concentrations to accurately determine the optimal concentration for maximal degradation (Dmax) and the onset of the hook effect.
Low cooperativity	Weak protein-protein interactions within the ternary complex make it less stable than the binary complexes at high concentrations.	Biophysical Assays (SPR, ITC, FRET/BRET): Quantify the cooperativity of the ternary complex. Aim to re-engineer the PROTAC to enhance positive cooperativity.
High cellular efflux	Efflux pumps may be actively removing the PROTAC from the cell, affecting its intracellular concentration and contributing to complex dose-response behaviors.	Efflux Pump Inhibition Studies: Co-treat with known efflux pump inhibitors to see if the hook effect is altered.

## Quantitative Data Summary

The following tables summarize key quantitative data to illustrate the impact of linker length and E3 ligase choice on PROTAC performance.

Table 1: Impact of Linker Length on Estrogen Receptor (ER)  $\alpha$  Degradation

PROTAC Compound	Linker Length (atoms)	Degradation Efficacy
11	9	Moderate
12	12	High
13	16	Very High (Optimal)
14	19	Moderate
15	21	Low

Data adapted from studies on ER $\alpha$ -targeting PROTACs, demonstrating a clear optimal linker length for maximal degradation.

Table 2: Comparative Efficacy of VHL and CRBN-based PROTACs for BRD4 Degradation

PROTAC	Recruited E3 Ligase	Target	DC50	Dmax	Cell Line	Reference
PROTAC 139	VHL	BRD4	3.3 nM	97%	PC3	
dBET1	CRBN	BRD4	~10 nM	>95%	MV4-11	
ARV-771	VHL	BET Bromodomains	-	-	-	
ARV-110	CRBN	Androgen Receptor	1 nM	85%	VCaP	
DT2216	VHL	BCL-XL	63 nM	90.8%	MOLT-4	

This table provides a comparative overview of the degradation potency and efficacy of PROTACs recruiting either VHL or CRBN against various targets.

## Experimental Protocols

## Detailed Methodology: Co-Immunoprecipitation (Co-IP) for Ternary Complex Detection

Objective: To qualitatively or semi-quantitatively demonstrate the PROTAC-dependent formation of a ternary complex between the target protein and the E3 ligase in a cellular context.

Materials:

- ER $\alpha$ -positive breast cancer cell line (e.g., MCF-7)
- PROTAC of interest
- Proteasome inhibitor (e.g., MG132)
- Non-denaturing cell lysis buffer (e.g., 50 mM Tris-HCl pH 7.4, 150 mM NaCl, 1 mM EDTA, 1% NP-40, with freshly added protease and phosphatase inhibitors)
- Primary antibody for immunoprecipitation (e.g., Rabbit anti-VHL or anti-CRBN)
- Negative control IgG (e.g., Rabbit IgG)
- Protein A/G agarose beads
- Wash buffer (e.g., lysis buffer with lower detergent concentration)
- SDS-PAGE loading buffer
- Primary antibodies for Western blot (e.g., Mouse anti-ER $\alpha$ , Rabbit anti-VHL/CRBN)
- Appropriate secondary antibodies

Procedure:

- Cell Treatment: Seed MCF-7 cells and allow them to adhere. Treat the cells with the PROTAC at its optimal concentration, a vehicle control (e.g., DMSO), and a combination of the PROTAC and MG132 (to prevent degradation of the complex). Incubate for the desired time (e.g., 4 hours).

- **Cell Lysis:** Wash cells with ice-cold PBS and lyse with non-denaturing lysis buffer on ice. Centrifuge to pellet cell debris and collect the supernatant.
- **Protein Quantification:** Determine the protein concentration of the lysates and normalize all samples.
- **Pre-clearing:** Add Protein A/G agarose beads to the lysates and incubate to reduce non-specific binding. Centrifuge and collect the pre-cleared supernatant.
- **Immunoprecipitation:** Add the anti-VHL/CRBN antibody or control IgG to the pre-cleared lysates. Incubate overnight with rotation at 4°C.
- **Complex Capture:** Add Protein A/G agarose beads to capture the antibody-protein complexes. Incubate for 2-4 hours with rotation at 4°C.
- **Washing:** Pellet the beads and wash them multiple times with ice-cold wash buffer to remove non-specifically bound proteins.
- **Elution:** Elute the immunoprecipitated proteins from the beads by adding SDS-PAGE loading buffer and boiling.
- **Western Blot Analysis:** Separate the eluted proteins by SDS-PAGE, transfer to a membrane, and probe with antibodies against the target protein (ER $\alpha$ ) and the E3 ligase (VHL/CRBN). An increased signal for the target protein in the PROTAC-treated sample compared to the control indicates ternary complex formation.

## Detailed Methodology: Surface Plasmon Resonance (SPR) for Ternary Complex Kinetics

**Objective:** To quantitatively measure the binding affinities and kinetics of binary and ternary complex formation in vitro.

**Materials:**

- SPR instrument and sensor chips (e.g., Biacore™ with a Sensor Chip SA for streptavidin capture)

- Purified, biotinylated E3 ligase (e.g., VHL complex)
- Purified target protein (e.g., BRD4 bromodomain)
- PROTAC of interest
- SPR running buffer (e.g., HBS-EP+)

#### Procedure:

- E3 Ligase Immobilization: Immobilize the biotinylated E3 ligase onto the streptavidin-coated sensor chip surface.
- Binary Interaction Analysis (PROTAC to E3 Ligase): Inject a series of concentrations of the PROTAC over the immobilized E3 ligase surface to measure the binary binding affinity (KD) and kinetics ( $k_a$ ,  $k_d$ ).
- Binary Interaction Analysis (PROTAC to Target - Optional): If the target protein is immobilized, inject the PROTAC to determine its binary affinity for the target.
- Ternary Complex Analysis: Inject a solution containing a fixed, near-saturating concentration of the target protein mixed with a series of concentrations of the PROTAC over the immobilized E3 ligase surface.
- Data Analysis:
  - The sensorgrams from the ternary complex analysis will show an increased binding response compared to the PROTAC-only injections if a ternary complex is formed.
  - Fit the data to appropriate binding models to determine the affinity (KD) and kinetic parameters ( $k_a$ ,  $k_d$ ) of the ternary complex.
  - Calculate the cooperativity factor ( $\alpha$ ) using the formula:  $\alpha = (\text{KD of PROTAC to E3 ligase}) / (\text{KD of PROTAC to E3 ligase in the presence of the target protein})$ .

## Detailed Methodology: NanoBRET™ Ternary Complex Assay in Live Cells

Objective: To measure PROTAC-induced ternary complex formation in real-time within living cells.

Materials:

- HEK293 cells (or other suitable cell line)
- Expression vectors for NanoLuc®-fusion of the target protein and HaloTag®-fusion of the E3 ligase.
- Transfection reagent
- NanoBRET™ Nano-Glo® Substrate
- HaloTag® NanoBRET™ 618 Ligand
- PROTAC of interest
- Luminometer with appropriate filters (460 nm for donor, >600 nm for acceptor)

Procedure:

- Cell Transfection: Co-transfect cells with the NanoLuc®-target protein and HaloTag®-E3 ligase expression vectors. Plate the transfected cells in a multi-well plate.
- HaloTag® Labeling: Add the HaloTag® NanoBRET™ 618 Ligand to the cells and incubate to allow for covalent labeling of the HaloTag®-fusion protein.
- PROTAC Treatment: Add a serial dilution of the PROTAC to the cells. Include a vehicle control.
- Substrate Addition and Signal Detection: Add the NanoBRET™ Nano-Glo® Substrate. Immediately measure the donor emission (460 nm) and acceptor emission (618 nm) using a luminometer.
- Data Analysis: Calculate the NanoBRET™ ratio by dividing the acceptor signal by the donor signal. A PROTAC-dependent increase in the NanoBRET™ ratio indicates the formation of

the ternary complex. Plot the NanoBRET™ ratio against the PROTAC concentration to generate a dose-response curve.

## Visualizations

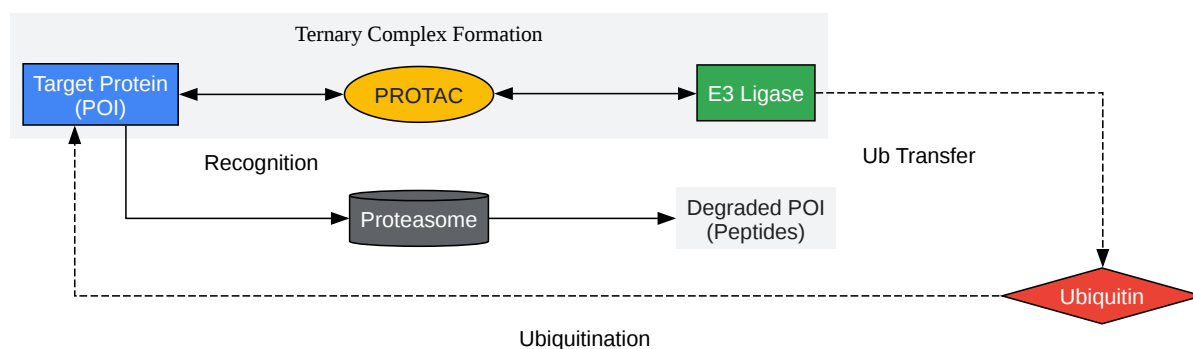

[Click to download full resolution via product page](#)

Caption: The mechanism of PROTAC-mediated protein degradation.

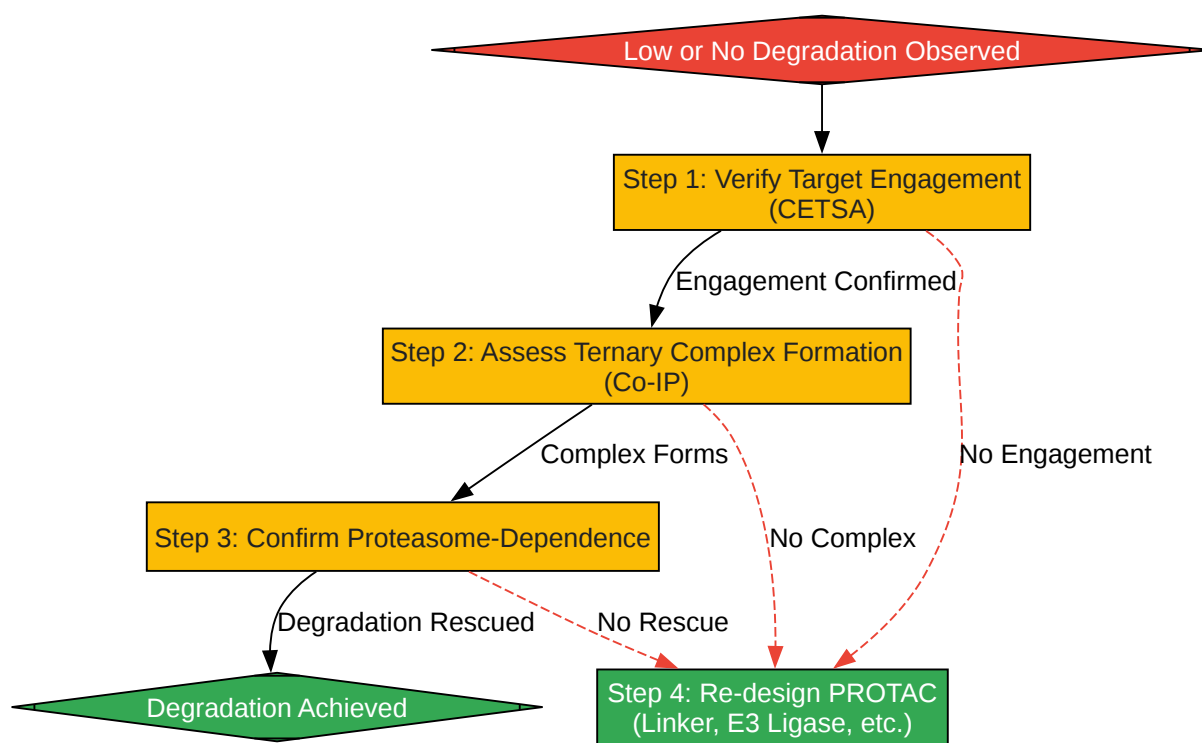

[Click to download full resolution via product page](#)

Caption: A logical workflow for troubleshooting low PROTAC efficacy.

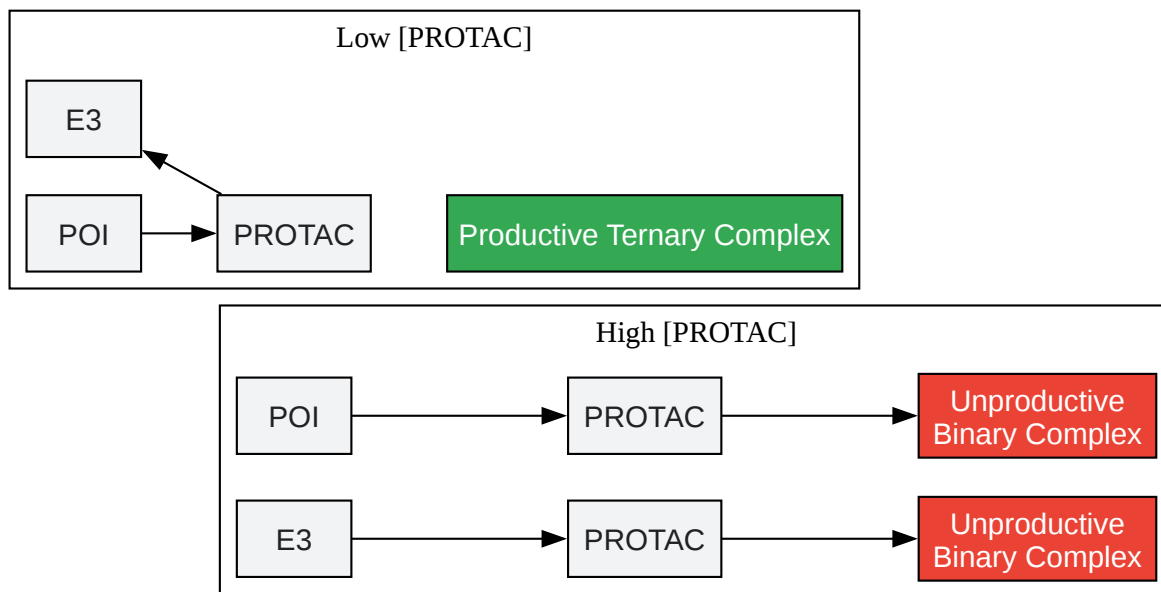

[Click to download full resolution via product page](#)

Caption: The formation of unproductive binary complexes at high PROTAC concentrations causes the "hook effect".

### Need Custom Synthesis?

BenchChem offers custom synthesis for rare earth carbides and specific isotopic labeling.

Email: [info@benchchem.com](mailto:info@benchchem.com) or [Request Quote Online](#).

## References

- [1. benchchem.com](https://www.benchchem.com) [benchchem.com]
- [2. researchgate.net](https://www.researchgate.net) [researchgate.net]
- [3. benchchem.com](https://www.benchchem.com) [benchchem.com]
- [4. benchchem.com](https://www.benchchem.com) [benchchem.com]

- To cite this document: BenchChem. [Technical Support Center: Optimizing PROTAC Ternary Complex Formation]. BenchChem, [2026]. [Online PDF]. Available at: [<https://www.benchchem.com/product/b11935376/docs#technical-support-center-optimizing-protac-ternary-complex-formation>]

---

### Disclaimer & Data Validity:

The information provided in this document is for Research Use Only (RUO) and is strictly not intended for diagnostic or therapeutic procedures. While BenchChem strives to provide accurate protocols, we make no warranties, express or implied, regarding the fitness of this product for every specific experimental setup.

**Technical Support:** The protocols provided are for reference purposes. Unsure if this reagent suits your experiment?

**Need Industrial/Bulk Grade?** [Request Custom Synthesis Quote](#)

## BenchChem

Our mission is to be the trusted global source of essential and advanced chemicals, empowering scientists and researchers to drive progress in science and industry.

### Contact

Address: 3281 E Guasti Rd  
Ontario, CA 91761, United States  
Phone: (601) 213-4426  
Email: [info@benchchem.com](mailto:info@benchchem.com)

[Contact our Ph.D. Support Team for a compatibility check](#)