

# Cross-Reactivity of Acromelic Acid D with Neurotransmitter Systems: A Comparative Guide

**Author:** BenchChem Technical Support Team. **Date:** December 2025

## Compound of Interest

Compound Name: *Acromelic acid D*

Cat. No.: *B15387709*

[Get Quote](#)

Disclaimer: Direct experimental data on the cross-reactivity of **Acromelic acid D** with various neurotransmitter systems is not readily available in the current scientific literature. This guide provides a comparative analysis based on the well-characterized pharmacology of its close structural analog, Acromelic acid A. Due to their analogous structures, it is presumed that **Acromelic acid D** exhibits a similar pharmacological profile, primarily acting as a potent agonist at ionotropic glutamate receptors, with a particular preference for kainate and AMPA receptor subtypes.

## Overview of Acromelic Acid D's Presumed Primary Target

**Acromelic acid D** belongs to a family of potent neuroexcitatory amino acids isolated from the poisonous mushroom *Clitocybe acromelalga*. Its structural analog, Acromelic acid A, is a well-established agonist of ionotropic glutamate receptors, which are crucial for fast excitatory neurotransmission in the central nervous system. The primary targets are believed to be the kainate and  $\alpha$ -amino-3-hydroxy-5-methyl-4-isoxazolepropionic acid (AMPA) receptors.<sup>[1][2][3]</sup>

## Comparative Binding Affinities of Acromelic Acid A

The following table summarizes the binding affinities ( $K_i$  values) of Acromelic acid A for kainate and AMPA receptors in rat brain synaptic plasma membranes. These values provide an indication of the high potency of this class of compounds at these specific glutamate receptor subtypes.

Receptor Subtype	Radioligand	Acromelic Acid A Ki (nM)	Reference Compound	Reference Compound Ki (nM)
Kainate (High Affinity)	[3H]-Kainic Acid	15.1	Kainic Acid	19.4
Kainate (Low Affinity)	[3H]-Kainic Acid	1490	Domoic Acid	14.5
AMPA	[3H]-AMPA	26	AMPA	184
AMPA (+ SCN <sup>-</sup> )	[3H]-AMPA	289	Domoic Acid	9020

#### Data Interpretation:

- Acromelic acid A demonstrates a high affinity for a subpopulation of kainate receptors, with a Ki value of 15.1 nM.[1]
- It also interacts with a lower affinity kainate binding site.[1]
- Notably, in the absence of thiocyanate ions (SCN<sup>-</sup>), Acromelic acid A is a more potent displacer of [3H]-AMPA than AMPA itself, indicating a strong interaction with the AMPA receptor.[1]

## Presumed Signaling Pathways

**Acromelic acid D**, like Acromelic acid A, is expected to exert its effects by directly binding to and activating kainate and AMPA receptors. This activation leads to the opening of ion channels permeable to sodium (Na<sup>+</sup>) and, in the case of certain AMPA and kainate receptor subunit combinations, calcium (Ca<sup>2+</sup>). The resulting influx of cations causes neuronal depolarization, leading to an excitatory postsynaptic potential and, at high concentrations, excitotoxicity.

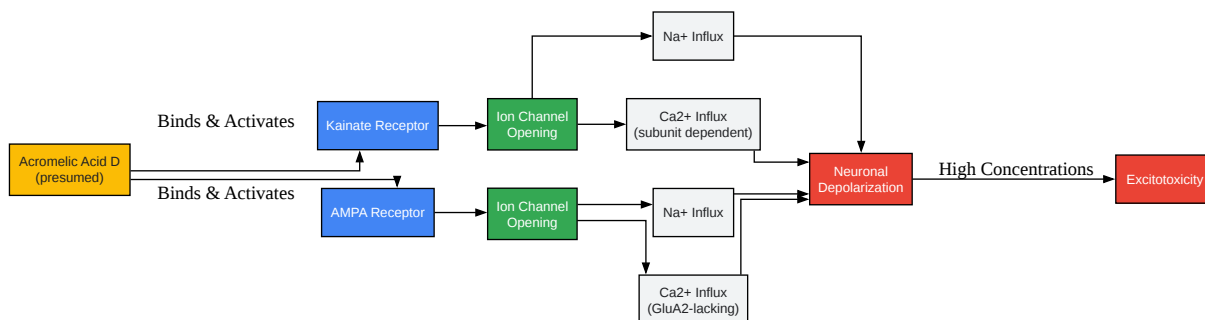

[Click to download full resolution via product page](#)

Caption: Presumed signaling pathway of **Acromelic acid D**.

## Experimental Protocols

The following are detailed methodologies for key experiments that would be utilized to determine the cross-reactivity and binding affinity of **Acromelic acid D**.

### Radioligand Binding Assay

This assay is the gold standard for determining the binding affinity of a compound for a specific receptor.

Objective: To determine the inhibitory constant ( $K_i$ ) of **Acromelic acid D** for various neurotransmitter receptors.

Materials:

- Rat brain synaptic plasma membranes
- Radioligands specific for the receptors of interest (e.g., [ $^3\text{H}$ ]-Kainic Acid for kainate receptors, [ $^3\text{H}$ ]-AMPA for AMPA receptors, [ $^3\text{H}$ ]-CNQX for AMPA/kainate receptors, [ $^3\text{H}$ ]-

CGP 39653 for NMDA receptors, etc.)

- **Acromelic acid D**
- Assay buffer (e.g., 50 mM Tris-HCl, pH 7.4)
- Glass fiber filters
- Scintillation counter

Procedure:

- **Membrane Preparation:** Homogenize rat brain tissue in ice-cold buffer and centrifuge to isolate the synaptic plasma membrane fraction. Resuspend the pellet in fresh buffer.
- **Assay Setup:** In a microplate, combine the membrane preparation, a fixed concentration of the specific radioligand, and varying concentrations of **Acromelic acid D** (or a known reference compound).
- **Incubation:** Incubate the plates at a controlled temperature (e.g., 4°C or room temperature) for a sufficient time to reach equilibrium.
- **Filtration:** Rapidly filter the incubation mixture through glass fiber filters to separate bound from free radioligand.
- **Washing:** Wash the filters with ice-cold buffer to remove non-specifically bound radioligand.
- **Counting:** Place the filters in scintillation vials with scintillation fluid and measure the radioactivity using a scintillation counter.
- **Data Analysis:** Determine the concentration of **Acromelic acid D** that inhibits 50% of the specific radioligand binding (IC50). Calculate the  $K_i$  value using the Cheng-Prusoff equation:  $K_i = IC_{50} / (1 + [L]/K_d)$ , where  $[L]$  is the concentration of the radioligand and  $K_d$  is its dissociation constant.

## Workflow for Radioligand Binding Assay

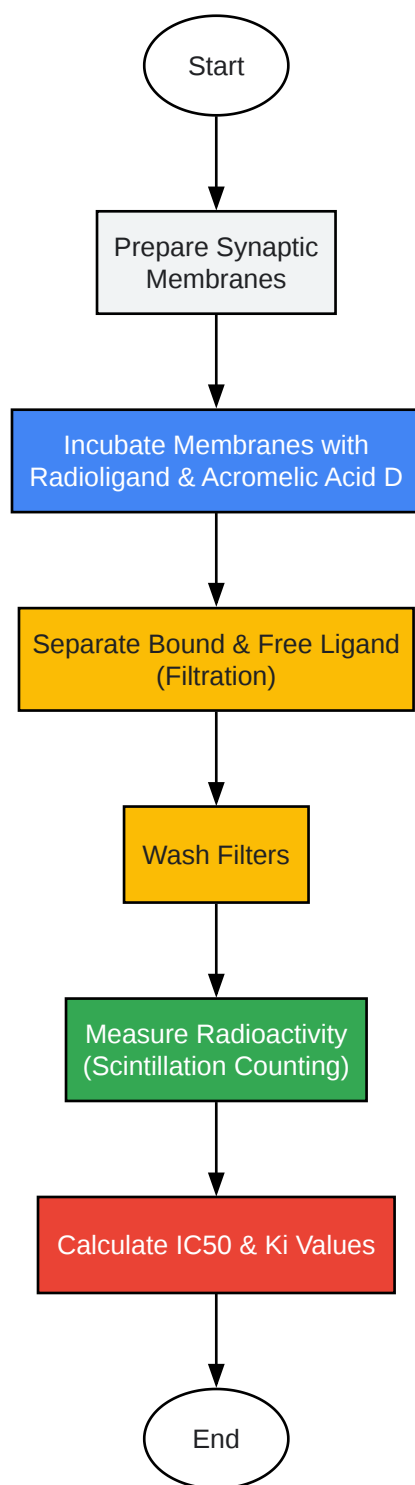

[Click to download full resolution via product page](#)

Caption: Workflow of a radioligand binding assay.

## Conclusion and Future Directions

Based on the data from its close analog, Acromelic acid A, it is highly probable that **Acromelic acid D** is a potent agonist at kainate and AMPA receptors with limited cross-reactivity to other major neurotransmitter systems at physiologically relevant concentrations. However, to definitively characterize the pharmacological profile of **Acromelic acid D**, direct experimental investigation is necessary. Future studies should include comprehensive radioligand binding screens against a broad panel of neurotransmitter receptors, transporters, and ion channels. Functional assays, such as electrophysiological recordings from cultured neurons or brain slices, would also be crucial to determine the functional consequences of **Acromelic acid D** binding to any identified off-target sites. Such studies are essential for a complete understanding of its neurotoxic effects and potential as a pharmacological tool.

### Need Custom Synthesis?

BenchChem offers custom synthesis for rare earth carbides and specific isotopic labeling.

Email: [info@benchchem.com](mailto:info@benchchem.com) or [Request Quote Online](#).

## References

- 1. Effects of acromelic acid A on the binding of [3H]-kainic acid and [3H]-AMPA to rat brain synaptic plasma membranes - PMC [pmc.ncbi.nlm.nih.gov]
- 2. Kainate receptor - Wikipedia [en.wikipedia.org]
- 3. AMPA receptor - Wikipedia [en.wikipedia.org]
- To cite this document: BenchChem. [Cross-Reactivity of Acromelic Acid D with Neurotransmitter Systems: A Comparative Guide]. BenchChem, [2025]. [Online PDF]. Available at: [<https://www.benchchem.com/product/b15387709#cross-reactivity-of-acromelic-acid-d-with-other-neurotransmitter-systems>]

### Disclaimer & Data Validity:

The information provided in this document is for Research Use Only (RUO) and is strictly not intended for diagnostic or therapeutic procedures. While BenchChem strives to provide accurate protocols, we make no warranties, express or implied, regarding the fitness of this product for every specific experimental setup.

**Technical Support:** The protocols provided are for reference purposes. Unsure if this reagent suits your experiment? [[Contact our Ph.D. Support Team for a compatibility check](#)]

**Need Industrial/Bulk Grade?** [Request Custom Synthesis Quote](#)

## BenchChem

Our mission is to be the trusted global source of essential and advanced chemicals, empowering scientists and researchers to drive progress in science and industry.

### Contact

Address: 3281 E Guasti Rd

Ontario, CA 91761, United States

Phone: (601) 213-4426

Email: [info@benchchem.com](mailto:info@benchchem.com)