

T-448 Technical Support Center: Optimizing Dosage and Mitigating Off-Target Effects

Author: BenchChem Technical Support Team. **Date:** April 2026

Compound of Interest

Compound Name: T-448
Cat. No.: B15376062

[Get Quote](#)

Welcome to the **T-448** Technical Support Center. To provide you with the most accurate guidance, please select the **T-448** compound you are working with:

- EOS-448 (also known as GSK4428859A or belrestotug): An anti-TIGIT monoclonal antibody.
- **T-448** (3-((1S,2R)-2-(cyclobutylamino)cyclopropyl)-N-(5-methyl-1,3,4-thiadiazol-2-yl)benzamide fumarate): A specific inhibitor of Lysine-Specific Demethylase 1 (LSD1).

EOS-448 (Anti-TIGIT Monoclonal Antibody)

Technical Support

This section provides troubleshooting guides and frequently asked questions (FAQs) to help researchers and drug development professionals optimize the dosage of EOS-448 and avoid potential off-target effects.

Frequently Asked Questions (FAQs)

Q1: What is the mechanism of action of EOS-448?

A1: EOS-448 is an antagonistic anti-TIGIT human immunoglobulin G1 (hIgG1) antibody.[1][2]

Its mechanism of action is multifaceted:

- TIGIT Blockade: It binds to the T-cell immunoglobulin and ITIM domain (TIGIT) receptor on T cells and Natural Killer (NK) cells, preventing its interaction with its ligands (e.g., CD155) on tumor cells. This blockade restores anti-tumor immune responses.
- Fcγ Receptor (FcγR) Engagement: As an IgG1 antibody, EOS-448's Fc region engages Fcγ receptors on immune cells, leading to:
 - Depletion of TIGIT-high regulatory T cells (Tregs) and exhausted T cells.[1][3][4]
 - Activation of antigen-presenting cells (APCs) and NK cells.

Q2: What are the known on-target and potential off-target effects of EOS-448?

A2: The primary on-target effects of EOS-448 are the restoration of T-cell function and the depletion of immunosuppressive cell populations. Potential off-target effects are primarily immune-related adverse events (irAEs) due to the broad activation of the immune system. These are generally considered "on-target, off-tumor" effects. Common side effects observed in clinical trials include fatigue, nausea, and infusion-related reactions.[5]

Q3: What is the recommended starting dose for preclinical in vivo studies?

A3: A starting dose for preclinical studies should be determined based on the specific animal model and experimental goals. However, based on clinical trial data where doses ranging from 20 mg to 1400 mg were evaluated, a dose-range finding study in a relevant animal model is recommended.[6]

Troubleshooting Guides

Issue 1: Suboptimal T-cell activation or tumor growth inhibition in preclinical models.

Possible Cause	Troubleshooting Step
Insufficient Dosage	Perform a dose-escalation study to determine the optimal dose for your model. Monitor pharmacodynamic markers such as Treg depletion and CD8+ T-cell activation.
Inappropriate Animal Model	Ensure the selected animal model has a compatible TIGIT pathway and expresses relevant ligands on tumor cells.
FcyR Engagement Issues	Confirm that the FcyR in your animal model can effectively interact with the human IgG1 Fc region of EOS-448.

Issue 2: Observation of significant immune-related adverse events (irAEs) in preclinical models.

Possible Cause	Troubleshooting Step
Dosage Too High	Reduce the dosage of EOS-448 and titrate to a level that maintains efficacy while minimizing toxicity.
Cytokine Release Syndrome	Monitor for signs of cytokine release syndrome (e.g., weight loss, ruffled fur, lethargy). Consider co-administration of agents to manage cytokine release.
On-Target, Off-Tumor Effects	Perform histological analysis of major organs to assess for immune cell infiltration and tissue damage.

Data Presentation

Table 1: Summary of Adverse Events from EOS-448 Phase 1 Clinical Trial[6]

Adverse Event	Grade	Frequency
Itching	1-2	Common
Infusion-related reactions	1-3	Common
Fatigue	1-2	Common
Rash	1-2	Common
Fever	1-2	Common
Systemic inflammatory response	2	One serious adverse event

Experimental Protocols

Protocol 1: Monitoring Immune Cell Populations by Flow Cytometry

This protocol outlines a method for monitoring changes in T-cell populations in peripheral blood or tumor tissue following EOS-448 treatment.

- Sample Preparation:
 - Isolate peripheral blood mononuclear cells (PBMCs) using density gradient centrifugation.
 - Prepare single-cell suspensions from tumor tissue by enzymatic digestion and mechanical dissociation.
- Antibody Staining:
 - Stain cells with a panel of fluorescently labeled antibodies to identify T-cell subsets. A recommended panel includes:
 - CD3 (T-cell marker)
 - CD4 (Helper T-cell marker)
 - CD8 (Cytotoxic T-cell marker)

- FoxP3 (Treg marker)
- TIGIT
- Ki-67 (Proliferation marker)
- CD25 (Activation marker)
- CD127 (IL-7 receptor)
- Flow Cytometry Analysis:
 - Acquire data on a flow cytometer.
 - Gate on live, single cells, then on CD3+ T cells.
 - Further gate on CD4+ and CD8+ populations.
 - Within the CD4+ population, identify Tregs as CD25^{high}FoxP3⁺.
 - Quantify the percentage and absolute number of each cell population.
 - Assess TIGIT expression levels on different T-cell subsets.

Mandatory Visualization

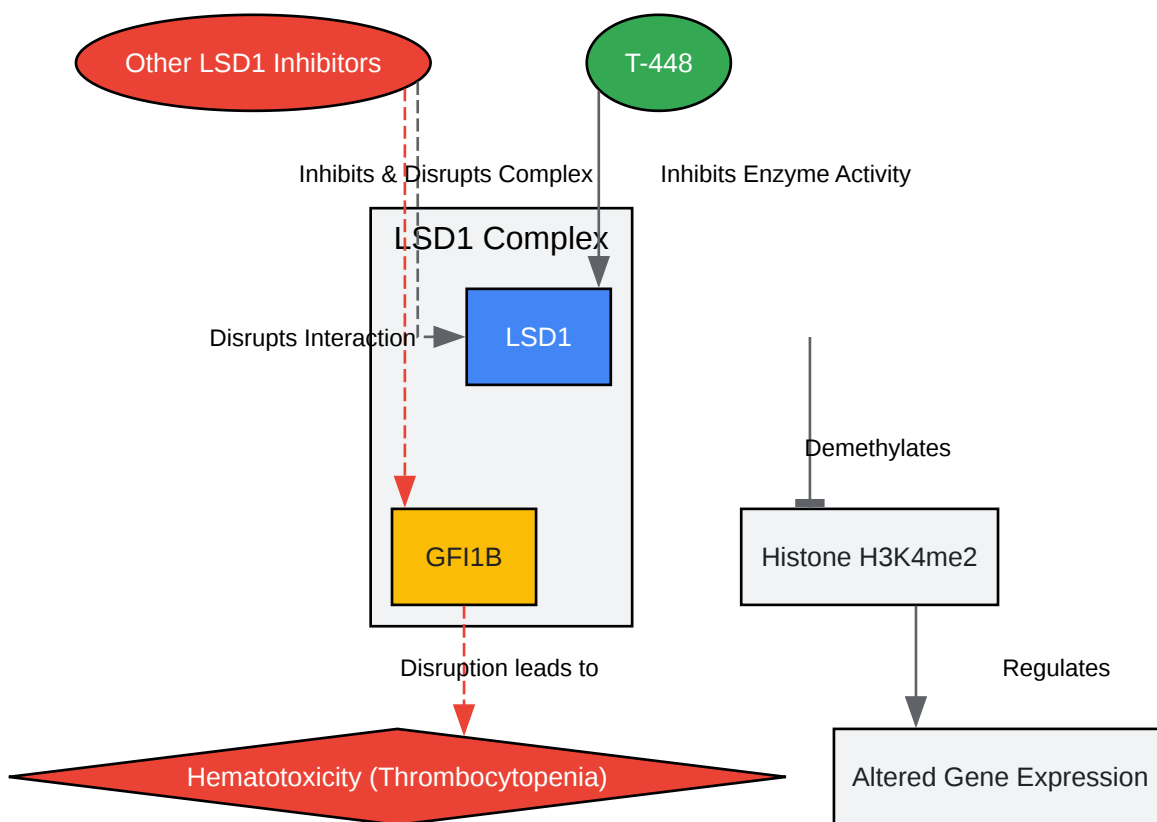
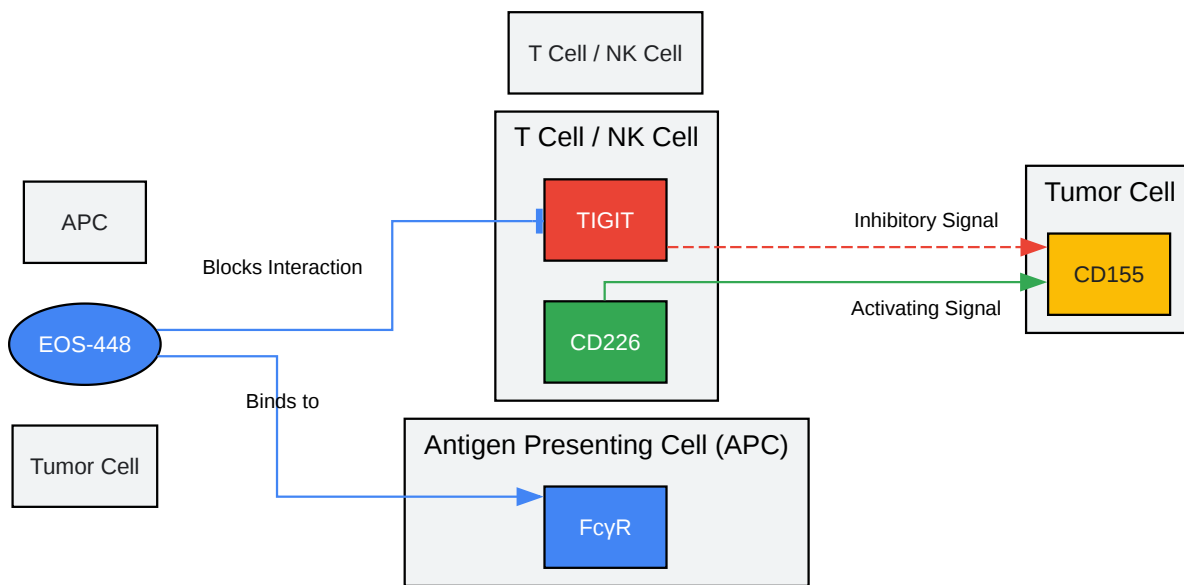

[Click to download full resolution via product page](#)

Need Custom Synthesis?

BenchChem offers custom synthesis for rare earth carbides and specific isotopic labeling.

Email: info@benchchem.com or [Request Quote Online](#).

References

- [1. researchgate.net \[researchgate.net\]](https://www.researchgate.net)
- [2. LSD1 inhibitors for cancer treatment: Focus on multi-target agents and compounds in clinical trials - PubMed \[pubmed.ncbi.nlm.nih.gov\]](https://pubmed.ncbi.nlm.nih.gov/)
- [3. hbmpartners.com \[hbmpartners.com\]](https://www.hbmpartners.com)
- [4. iTeos Announces New Data for its Anti-TIGIT Antibody, EOS-448, at the American Society of Hematology Annual Meeting and TIGIT Therapies Digital Summit 2021 - BioSpace \[biospace.com\]](https://www.biospace.com)
- [5. kuickresearch.com \[kuickresearch.com\]](https://www.kuickresearch.com)
- [6. iTeos Therapeutics Announces New Preliminary Data \[globenewswire.com\]](https://www.globenewswire.com)
- To cite this document: BenchChem. [T-448 Technical Support Center: Optimizing Dosage and Mitigating Off-Target Effects]. BenchChem, [2026]. [Online PDF]. Available at: [\[https://www.benchchem.com/product/b15376062/docs#t-448-technical-support-center-optimizing-dosage-and-mitigating-off-target-effects\]](https://www.benchchem.com/product/b15376062/docs#t-448-technical-support-center-optimizing-dosage-and-mitigating-off-target-effects)

Disclaimer & Data Validity:

The information provided in this document is for Research Use Only (RUO) and is strictly not intended for diagnostic or therapeutic procedures. While BenchChem strives to provide accurate protocols, we make no warranties, express or implied, regarding the fitness of this product for every specific experimental setup.

Technical Support: The protocols provided are for reference purposes. Unsure if this reagent suits your experiment?

Need Industrial/Bulk Grade? [Request Custom Synthesis Quote](#)

BenchChem

Our mission is to be the trusted global source of essential and advanced chemicals, empowering scientists and researchers to drive progress in science and industry.

Contact

Address: 3281 E Guasti Rd

Ontario, CA 91761, United States

Phone: (601) 213-4426

Email: info@benchchem.com

[Contact our Ph.D. Support Team for a compatibility check](#)