

Technical Support Center: Temperature Optimization for 4-Bromoquinoline Substitution

Author: BenchChem Technical Support Team. **Date:** April 2026

Compound of Interest

Compound Name: 4-Bromo-6,8-dimethoxyquinoline

Cat. No.: B15354968

[Get Quote](#)

Core Directive: The Reactivity Landscape

The 4-bromoquinoline scaffold presents a unique reactivity profile. Unlike standard aryl halides, the nitrogen atom in the quinoline ring renders the C4 position highly electrophilic, activating it for Nucleophilic Aromatic Substitution (

). However, this activation is double-edged: it facilitates the desired substitution but also makes the substrate prone to hydrolysis (formation of 4-hydroxyquinoline/quinolone) and polymerization at elevated temperatures.

The Critical Decision: Temperature optimization is not just about "heating it up." It is a function of the Nucleophile Strength, Catalytic Strategy, and Solvent Polarity.

Decision Matrix: Selecting the Right Methodology

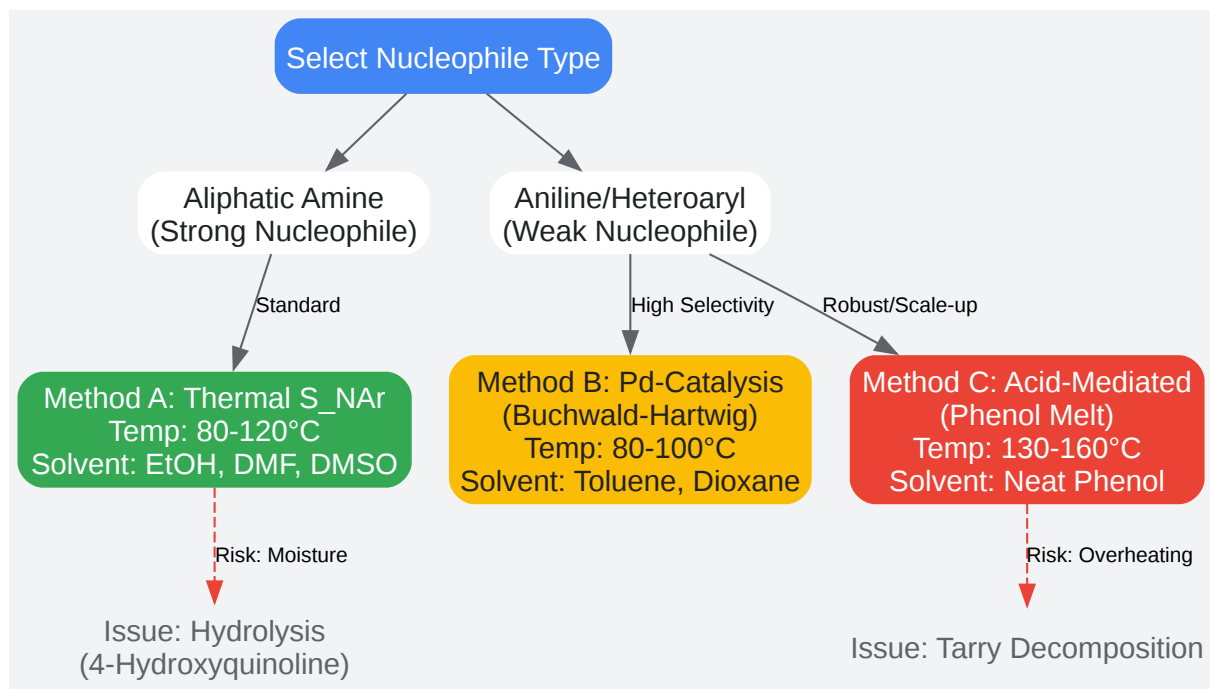

[Click to download full resolution via product page](#)

Figure 1: Decision matrix for selecting reaction conditions based on nucleophile type.

Troubleshooting Guide & FAQs

This section addresses specific failure modes encountered in the lab, synthesizing mechanistic insights with practical solutions.

Q1: My reaction stalls at 50% conversion even after 24h at reflux in Ethanol. Why?

Diagnosis: Ethanol (boiling point ~78°C) often fails to provide sufficient thermal energy to overcome the activation barrier for

on 4-bromoquinoline, especially with sterically hindered amines. **The Fix:**

- **Switch Solvent:** Move to a polar aprotic solvent like DMF or DMSO. These solvents stabilize the polar Meisenheimer intermediate (see Figure 2), effectively lowering the activation

energy [1].

- Increase Temperature: Target 120–140°C.
- Acid Catalysis: Add 1.0 eq of HCl (in dioxane) or use the "Phenol Melt" protocol (Method C). Protonation of the quinoline nitrogen () dramatically increases the electrophilicity at [2].

Q2: I observe a major side product with mass [M-79+17]. What is it?

Diagnosis: This is 4-hydroxyquinoline (or its tautomer, 4-quinolone).[1] It results from the hydrolysis of the C-Br bond by adventitious water. Causality: At high temperatures (>100°C), even trace moisture in "anhydrous" solvents becomes a potent nucleophile, competing with your amine. The Fix:

- Strict Moisture Control: Flame-dry glassware and use molecular sieves in the reaction vessel.
- Buffer the System: If using acid catalysis, ensure the system is sealed.
- Temperature Ceiling: Do not exceed 150°C unless absolutely necessary; hydrolysis rates scale exponentially with temperature [3].

Q3: Why does 4-Chloroquinoline sometimes react faster than 4-Bromoquinoline in

?

Expert Insight: In classical

, the rate-determining step is the attack of the nucleophile, not the breaking of the C-X bond. Highly electronegative atoms (F > Cl) stabilize the transition state more effectively than Br or I.

- Order: F >> Cl
Br > I

- Pd-Catalyzed Order: I > Br > Cl >> F (Bond breaking is rate-determining)
- Actionable Advice: If you are running a standard thermal substitution and it is sluggish, switching to the 4-fluoro analog (if available) or using acid catalysis (which levels the electronegativity difference) may be more effective than simply increasing temperature [4].

Q4: My Pd-catalyzed reaction turns black and yields are low. Is it temperature?

Diagnosis: "Palladium black" formation indicates catalyst decomposition, often caused by overheating or lack of stabilizing ligands. The Fix:

- Lower Temperature: Buchwald-Hartwig reactions on 4-bromoquinoline typically work well at 80–100°C. Going above 110°C often degrades the catalyst before the reaction completes.
- Ligand Choice: Use robust ligands like XPhos or BrettPhos which form stable catalytic species at elevated temperatures [5].

Experimental Protocols

Protocol A: Thermal

(For Primary/Secondary Alkyl Amines)

Best for: Simple aliphatic amines (e.g., morpholine, butylamine).

- Setup: 10 mL microwave vial or pressure tube.
- Reagents: 4-bromoquinoline (1.0 mmol), Amine (1.5 mmol), DIPEA (2.0 mmol).
- Solvent: NMP (N-Methyl-2-pyrrolidone) or DMSO (3 mL). Note: Avoid EtOH for difficult substrates.
- Temperature: Heat to 120°C.
- Time: 2–6 hours.
- Workup: Dilute with water (crash out product) or extract with EtOAc.

- Validation: TLC should show complete consumption of SM (in 50% EtOAc/Hex).

Protocol B: The "Phenol Melt" (For Weak Nucleophiles/Anilines)

Best for: Anilines, sterically hindered amines. This is an "Expert" protocol leveraging acid catalysis and solvent effects.

- Setup: Round bottom flask with reflux condenser.
- Reagents: 4-bromoquinoline (1.0 mmol), Aniline derivative (1.1 mmol).
- Solvent/Catalyst: Phenol (solid) (4-5 equivalents).
- Mechanism: Phenol acts as both a high-boiling solvent and a proton shuttle, activating the quinoline nitrogen.
- Temperature: Heat to 140–160°C (melt).
- Time: 1–4 hours.
- Workup: Cool to RT. Dilute with EtOAc. Wash extensively with 1M NaOH to remove phenol.
- Note: This method is robust against moisture compared to Pd-catalysis [6].

Protocol C: Pd-Catalyzed Buchwald-Hartwig

Best for: Very weak nucleophiles, amides, or when regioselectivity is critical.

- Setup: Schlenk tube (inert atmosphere required).
- Reagents: 4-bromoquinoline (1.0 mmol), Amine (1.2 mmol), NaOtBu (1.4 mmol).
- Catalyst:
(2 mol%), XPhos (4 mol%).
- Solvent: Anhydrous Toluene or Dioxane.

- Temperature: 80–100°C. Do not exceed 110°C.
- Time: 12–18 hours.

Data & Visualization

Comparative Efficiency Table

Variable	Thermal (EtOH)	Thermal (DMSO)	Phenol Melt	Pd-Catalysis
Temp Range	78°C (Reflux)	120–150°C	140–160°C	80–100°C
Reaction Time	12–48 h	2–6 h	1–4 h	8–16 h
Yield (Aniline)	<10% (Poor)	30–50% (Moderate)	85–95% (Excellent)	80–90% (Good)
Yield (Alkyl Amine)	60–70%	90–95%	N/A (Overkill)	N/A
Key Risk	Incomplete Rxn	Polymerization	Difficult Workup	Catalyst Death

Mechanistic Pathway: Thermal vs. Acid-Catalyzed

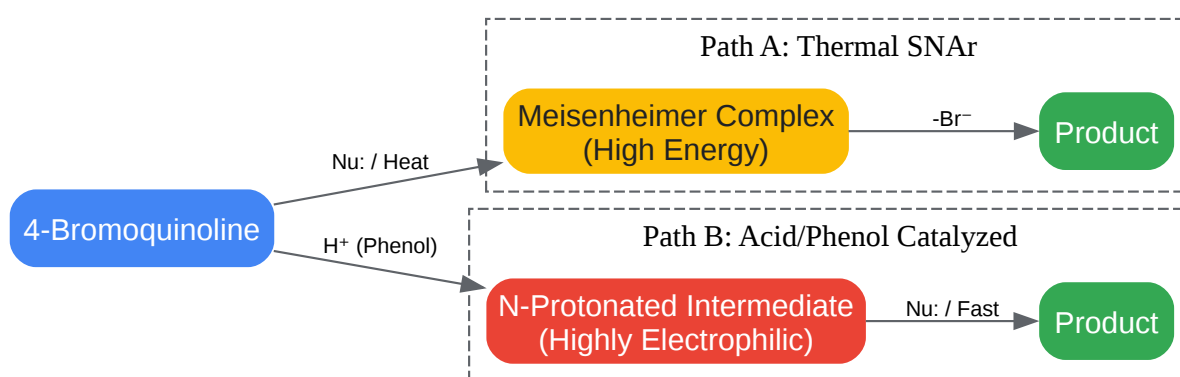

[Click to download full resolution via product page](#)

Figure 2: Comparison of standard thermal pathway vs. acid-activated pathway. Note the protonation step lowers the activation energy for nucleophilic attack.

References

- Solvent Effects in

: Bunnett, J. F., & Zahler, R. E. (1951). Chemical Reviews. "Nucleophilic Substitution Reactions in Aromatic Systems."
- Acid Catalysis in Quinoline Substitution: Surrey, A. R., & Cutler, R. A. (1951). Journal of the American Chemical Society. "The Preparation of 4-Aminoquinolines."
- Hydrolysis Side Reactions: Schofield, K. (1967). Hetero-aromatic Nitrogen Compounds: Pyrroles and Pyridines. Butterworths.
- Halogen Reactivity Order: Miller, J. (1968). Aromatic Nucleophilic Substitution. Elsevier.
- Buchwald-Hartwig Conditions: Surry, D. S., & Buchwald, S. L. (2008). Angewandte Chemie International Edition. "Biaryl Phosphane Ligands in Palladium-Catalyzed Amination."
- Phenol Melt Protocol: Wolf, C., et al. (2008). Journal of Organic Chemistry. "Efficient Synthesis of 4-Aminoquinolines."

Need Custom Synthesis?

BenchChem offers custom synthesis for rare earth carbides and specific isotopic labeling.

Email: info@benchchem.com or [Request Quote Online](#).

Sources

- [1. derisilab.ucsf.edu](http://1.derisilab.ucsf.edu) [derisilab.ucsf.edu]
- To cite this document: BenchChem. [Technical Support Center: Temperature Optimization for 4-Bromoquinoline Substitution]. BenchChem, [2026]. [Online PDF]. Available at: [<https://www.benchchem.com/product/b15354968/docs#technical-support-center-temperature-optimization-for-4-bromoquinoline-substitution>]

Disclaimer & Data Validity:

The information provided in this document is for Research Use Only (RUO) and is strictly not intended for diagnostic or therapeutic procedures. While BenchChem strives to provide

accurate protocols, we make no warranties, express or implied, regarding the fitness of this product for every specific experimental setup.

Technical Support: The protocols provided are for reference purposes. Unsure if this reagent suits your experiment?

Need Industrial/Bulk Grade? [Request Custom Synthesis Quote](#)

BenchChem

Our mission is to be the trusted global source of essential and advanced chemicals, empowering scientists and researchers to drive progress in science and industry.

Contact

Address: 3281 E Guasti Rd

Ontario, CA 91761, United States

Phone: (601) 213-4426

Email: info@benchchem.com

[Contact our Ph.D. Support Team for a compatibility check](#)