

Technical Support Center: Acid-Mediated Ring Closure Reactions

Author: BenchChem Technical Support Team. **Date:** May 2026

Compound of Interest

Compound Name: 2-Bromo-N-(2,2-diethoxyethyl)acetamide

CAS No.: 1202781-08-5

Cat. No.: B15345252

[Get Quote](#)

Welcome to the Technical Support Center for Acid-Mediated Ring Closure. This guide is designed for researchers, chemists, and drug development professionals who encounter challenges with byproduct formation during these critical synthetic transformations. As your Senior Application Scientist, my goal is to provide not just protocols, but a deep, mechanistic understanding to empower you to troubleshoot and optimize your reactions effectively.

Acid-catalyzed cyclizations are powerful tools for constructing cyclic scaffolds, but they are often plagued by competing reaction pathways that lead to undesired byproducts such as polymers, elimination products, and regioisomers. Understanding the delicate balance of kinetics and thermodynamics, and the subtle interplay between substrate, catalyst, solvent, and temperature, is paramount to success. This guide provides field-proven insights and actionable protocols to help you navigate these complexities and enhance the selectivity of your ring-closure reactions.

Troubleshooting Guide

This section addresses specific, common problems encountered during acid-mediated cyclization experiments. Each answer delves into the root chemical causes and provides concrete steps for resolution.

Q1: My reaction is yielding significant polymeric or dimeric byproducts. How can I favor the desired intramolecular cyclization?

A1: The formation of polymers or dimers is a classic sign that an intermolecular reaction is outcompeting your desired intramolecular ring closure. This is fundamentally a concentration-dependent problem. The intramolecular pathway is a first-order process (rate depends on the concentration of your substrate), while the intermolecular pathway is second-order (rate depends on the concentration of your substrate squared). Therefore, the key is to manipulate conditions to favor the first-order kinetics.

Core Strategy: High-Dilution Conditions

The most effective strategy is to perform the reaction under high-dilution conditions. By significantly lowering the substrate concentration, you decrease the probability of two substrate molecules encountering each other, thus suppressing the intermolecular pathway.^[1]

Step-by-Step Protocol for High-Dilution Reaction:

- **Setup:** Use a large-volume reaction flask, typically 1000 mL or greater, equipped with a mechanical stirrer and a dropping funnel.
- **Solvent:** Fill the flask with the bulk of the anhydrous solvent. Ensure the solvent is appropriate for your reaction and capable of fully dissolving your substrate at low concentrations.
- **Catalyst:** Add the acid catalyst to the solvent in the main reaction flask.
- **Slow Addition:** Dissolve your substrate in a small amount of the same anhydrous solvent and place it in the dropping funnel. Add the substrate solution dropwise to the stirred, heated catalyst-solvent mixture over an extended period (e.g., 4-12 hours). This maintains a pseudo-low concentration of the uncyclized substrate in the flask at any given moment.

- Monitoring: Monitor the reaction by TLC or LCMS to ensure the starting material is being consumed and to avoid excessive reaction times that might lead to degradation.

Table 1: General Parameters to Favor Intramolecular vs. Intermolecular Reactions

Parameter	To Favor Intramolecular Cyclization	To Favor Intermolecular Reaction (Polymerization)	Rationale
Concentration	Low (0.001 - 0.05 M)	High (> 0.1 M)	Favors first-order kinetics over second-order.[1]
Addition Rate	Slow (Syringe pump or dropping funnel over hours)	Rapid (All at once)	Maintains a consistently low concentration of reactant.
Temperature	Optimized for cyclization	Often higher temperatures can increase reaction rates	Temperature should be high enough for cyclization but low enough to avoid degradation.

Q2: I'm observing significant elimination byproducts (e.g., C=C bond formation) instead of the desired ring. What adjustments should I make?

A2: Elimination is a common competing pathway, especially when the reaction generates a carbocation intermediate that has an accessible proton on an adjacent carbon. The stability of the resulting alkene can be a strong thermodynamic driver. Minimizing elimination involves carefully selecting your acid catalyst and controlling the temperature.

Causality and Solutions:

- **Acid Strength:** Very strong Brønsted or Lewis acids can promote elimination by creating a highly reactive carbocation and a weakly coordinating conjugate base. The conjugate base may not be nucleophilic enough to assist in the desired cyclization but can facilitate deprotonation.
 - **Action:** Screen weaker acids. For instance, if concentrated sulfuric acid is causing elimination, consider milder Brønsted acids like p-toluenesulfonic acid (p-TsOH) or phosphoric acid (H₃PO₄).^[2] In some cases, Lewis acids that can coordinate with the nucleophile may be a better choice.
- **Temperature Control:** Higher temperatures provide the activation energy needed for elimination pathways.^[3] Many cyclizations can proceed at lower temperatures, albeit more slowly.
 - **Action:** Run the reaction at the lowest temperature that allows for a reasonable reaction rate. Start at 0 °C or even room temperature and only heat if necessary. Monitor progress closely.
- **Specialized Reagents:** For dehydrative cyclizations (e.g., Pictet-Spengler, Bischler-Napieralski), consider reagents specifically designed for this purpose that operate under milder conditions. Eaton's reagent (a solution of P₂O₅ in methanesulfonic acid) is a powerful dehydrating agent that often provides higher yields and fewer byproducts than polyphosphoric acid (PPA) at lower temperatures.^{[4][5][6]}

Q3: My reaction is producing a mixture of regioisomers. How can I improve selectivity?

A3: Regioisomer formation is dictated by the relative stability of intermediates and transition states. In acid-catalyzed reactions involving electrophilic attack on an aromatic ring (like Friedel-Crafts) or the opening of an unsymmetrical epoxide, the site of reaction is highly sensitive to both electronic and steric factors.

Strategies for Controlling Regioselectivity:

- **Solvent Effects:** The polarity of the solvent can dramatically influence product distribution. In some Friedel-Crafts acylations, for example, non-polar solvents like carbon disulfide (CS₂) or

dichloromethane (CH_2Cl_2) may favor the kinetic product, while more polar solvents like nitrobenzene can allow for equilibration to the more thermodynamically stable product.[7] This is often because the intermediate-catalyst complex may be insoluble in non-polar solvents, preventing reversal to form the thermodynamic product.[7]

- **Temperature Control:** Temperature can be a deciding factor between kinetic and thermodynamic control.[8] Lower temperatures often favor the kinetically preferred product (the one that forms faster), while higher temperatures can provide enough energy to overcome a higher activation barrier to form the more stable, thermodynamic product.[9] A study on intramolecular electrophilic ring closures showed that different cyclization modes (7-endo-dig vs. 6-endo-dig) could be favored by simply changing the reaction temperature from 40 °C to 90 °C.[8]
- **Catalyst Choice:** The size and nature of the Lewis acid can influence regioselectivity. A bulky Lewis acid might sterically hinder attack at one position, favoring another. For acid-catalyzed epoxide openings, the mechanism can be on the borderline between $\text{S}_{\text{n}}1$ and $\text{S}_{\text{n}}2$. [10][11] [12][13] With strong acids, there is significant positive charge buildup on the carbon that can best support it (tertiary > secondary), leading to nucleophilic attack at the more substituted position (an $\text{S}_{\text{n}}1$ -like outcome).[10] Milder conditions may favor attack at the less sterically hindered carbon (an $\text{S}_{\text{n}}2$ -like outcome).

Table 2: Example of Solvent Influence on Regioselectivity in the Friedel-Crafts Acetylation of Naphthalene

Solvent	Product Ratio (1-acetylnaphthalene : 2-acetylnaphthalene)	Product Type Favored	Rationale
Carbon Disulfide (CS ₂)	High ratio of 1-isomer	Kinetic	The 1-acetylnaphthalene-AlCl ₃ complex is insoluble, preventing equilibration.[7]
Nitrobenzene	High ratio of 2-isomer	Thermodynamic	The complex is soluble, allowing for reversal of the initial acylation and formation of the more stable isomer.[7]

Q4: The reaction is sluggish or stalls completely. How can I drive it to completion without increasing byproducts?

A4: A stalled reaction indicates that the activation energy barrier is not being overcome or that the catalyst has been deactivated. Simply increasing the temperature or adding more catalyst can often lead to byproduct formation.

Troubleshooting Steps:

- **Verify Catalyst Activity:** Ensure your catalyst is pure and active. Lewis acids like AlCl₃ or TiCl₄ are highly sensitive to moisture. Use freshly opened bottles or rigorously dried reagents. Ensure all glassware is flame-dried and the reaction is run under an inert atmosphere (e.g., argon or nitrogen).[14]
- **Consider a Stronger, Yet Selective, Catalyst:** If a mild acid is ineffective, a more potent catalyst system may be required. Eaton's reagent is often more effective than PPA and works

at lower temperatures.[6] A mixture of trifluoromethanesulfonic acid (TfOH) and P₄O₁₀ can also be highly effective for certain cyclizations.[15]

- **Substrate Inhibition/Coordination:** The substrate or product itself might be coordinating to the Lewis acid catalyst, effectively poisoning it. This is common with substrates containing basic nitrogen atoms (amines), which can bind tightly to Lewis acids.[16] In such cases, using a stoichiometric amount of the Lewis acid might be necessary, or choosing a Brønsted acid instead.
- **Removal of Byproducts:** Some cyclizations are reversible or produce inhibitory byproducts (like water in a dehydration reaction). Removing water using a Dean-Stark trap or molecular sieves can help drive the equilibrium toward the product.

Q5: I'm seeing degradation of my starting material or product. What is causing this and how can I prevent it?

A5: Degradation is typically caused by overly harsh reaction conditions—either the acid is too strong or the temperature is too high. Acid-sensitive functional groups on your molecule can be particularly susceptible.

Mitigation Strategies:

- **Reduce Acid Concentration/Strength:** Use the minimum amount of catalyst necessary. Screen weaker acids that are still effective for the cyclization. For example, some cyclizations that work with TfOH might also proceed with methanesulfonic acid (MsOH) with less degradation.
- **Lower the Temperature:** As a rule, run the reaction at the lowest feasible temperature. Even a reduction of 20 °C can significantly decrease the rate of decomposition.
- **Minimize Reaction Time:** Monitor the reaction closely and quench it as soon as the starting material is consumed. Unnecessarily long exposure to acidic conditions can degrade the desired product.
- **Protect Sensitive Groups:** If your substrate contains acid-labile functional groups that are not involved in the cyclization, consider protecting them before the ring-closure step and deprotecting them afterward.

Frequently Asked Questions (FAQs)

Q1: How do I select the appropriate acid catalyst (Lewis vs. Brønsted) for my substrate?

A1: The choice between a Lewis acid and a Brønsted acid is critical and depends on the reaction mechanism and the nature of your substrate.

- Brønsted Acids (e.g., H₂SO₄, p-TsOH, TfOH): These donate a proton. They are ideal for reactions that proceed through protonation of a functional group, such as activating a carbonyl for nucleophilic attack, intramolecular hydroalkoxylation of an alkene, or certain cascade cyclizations.^{[17][18]} They are often used in dehydrative cyclizations.
- Lewis Acids (e.g., AlCl₃, BF₃·OEt₂, TiCl₄, SnCl₄): These accept an electron pair. They excel at activating functional groups by coordination. They are the catalysts of choice for Friedel-Crafts acylations (generating an acylium ion) and some Nazarov cyclizations (activating a divinyl ketone).^{[19][20]} They can also be effective in cyclizations involving substrates with basic sites, though stoichiometric amounts may be needed.^[16]

Decision Workflow:

- Analyze the Mechanism: Does the key step involve protonation (use Brønsted) or complexation/generation of a cationic species like an acylium ion (use Lewis)?
- Consider the Substrate: Does your substrate have basic groups (e.g., amines) that could be protonated by a Brønsted acid (potentially deactivating the nucleophile) or that might irreversibly bind to a Lewis acid?^[16]
- Review the Literature: Look for precedents with similar substrates. The choice of acid is often empirically determined and highly substrate-dependent.

Q2: What is the role of the solvent in controlling byproduct formation?

A2: The solvent plays a multifaceted role beyond simply dissolving the reactants. It can influence reaction rates, equilibria, and the stability of intermediates, all of which affect selectivity.

- **Polarity:** As discussed in the Troubleshooting Guide (Q3), solvent polarity can determine whether a reaction is under kinetic or thermodynamic control by affecting the solubility of intermediate complexes.[7]
- **Coordinating vs. Non-Coordinating:** Solvents like acetonitrile or THF can coordinate with Lewis acid catalysts, potentially moderating their reactivity or inhibiting them altogether.[21] Non-coordinating solvents like dichloromethane, chloroform, or nitrobenzene are often preferred for Lewis acid-catalyzed reactions.
- **Protic vs. Aprotic:** Protic solvents (e.g., alcohols, water) are generally incompatible with strong Lewis acids and moisture-sensitive reagents. Anhydrous, aprotic solvents are the standard for most of these reactions.[14][22]

Q3: How does temperature influence the outcome of an acid-mediated cyclization?

A3: Temperature is one of the most powerful variables for controlling selectivity. Its influence stems from its role in overcoming activation energy barriers.

- **Kinetic vs. Thermodynamic Control:** This is the most common effect. Lower temperatures favor the product that forms fastest (kinetic product), while higher temperatures allow for equilibrium to be established, favoring the most stable product (thermodynamic product).[8][9]
- **Competing Pathways:** Different reaction pathways (e.g., cyclization vs. elimination vs. rearrangement) will have different activation energies. By adjusting the temperature, you can favor one pathway over another. For instance, a desired cyclization might proceed at room temperature, while a higher-energy elimination pathway only becomes significant at elevated temperatures.[3]
- **Reaction Rate vs. Degradation:** While higher temperatures increase the rate of the desired reaction, they also accelerate the rate of degradation. The optimal temperature is a balance between achieving a practical reaction time and minimizing the decomposition of starting materials and products.[3]

Q4: What are common pitfalls in specific named reactions like the Nazarov or Friedel-Crafts cyclizations?

A4:

- Nazarov Cyclization: This acid-catalyzed 4π -electrocyclic ring closure of a divinyl ketone is a powerful method for making cyclopentenones.[\[19\]](#)[\[23\]](#)[\[24\]](#)
 - Pitfall 1: Regioselectivity: In unsymmetrical divinyl ketones, the elimination step to form the final double bond can lead to mixtures of products. The double bond generally forms to give the most substituted, thermodynamically favored alkene.[\[20\]](#)
 - Pitfall 2: Stereoselectivity: Stereocenters alpha to the ketone can be prone to epimerization under the strongly acidic conditions, leading to low diastereoselectivity.[\[20\]](#)
 - Solution: Modern variants use directing groups (e.g., a silicon group) to control the regioselectivity of the elimination step.[\[20\]](#) Using milder catalysts or chiral Lewis acids can sometimes improve stereocontrol.
- Intramolecular Friedel-Crafts Acylation: This is a key C-C bond-forming reaction to build polycyclic aromatic systems.
 - Pitfall 1: Ring Strain: The reaction is generally only effective for forming 5- and 6-membered rings. Attempts to form 7-membered rings or larger are often difficult due to unfavorable thermodynamics and ring strain.
 - Pitfall 2: Deactivation: The product ketone is less electron-rich than the starting material and will form a complex with the Lewis acid catalyst. Therefore, at least a stoichiometric amount of the Lewis acid is required.
 - Solution: For challenging cyclizations, stronger catalyst systems like Eaton's reagent or neat TfOH may be necessary. Ensure at least 1.1 equivalents of the Lewis acid are used.

Visualizations and Workflows

Decision-Making Workflow for Troubleshooting

This diagram outlines a logical sequence for diagnosing and solving common issues in acid-mediated cyclization.

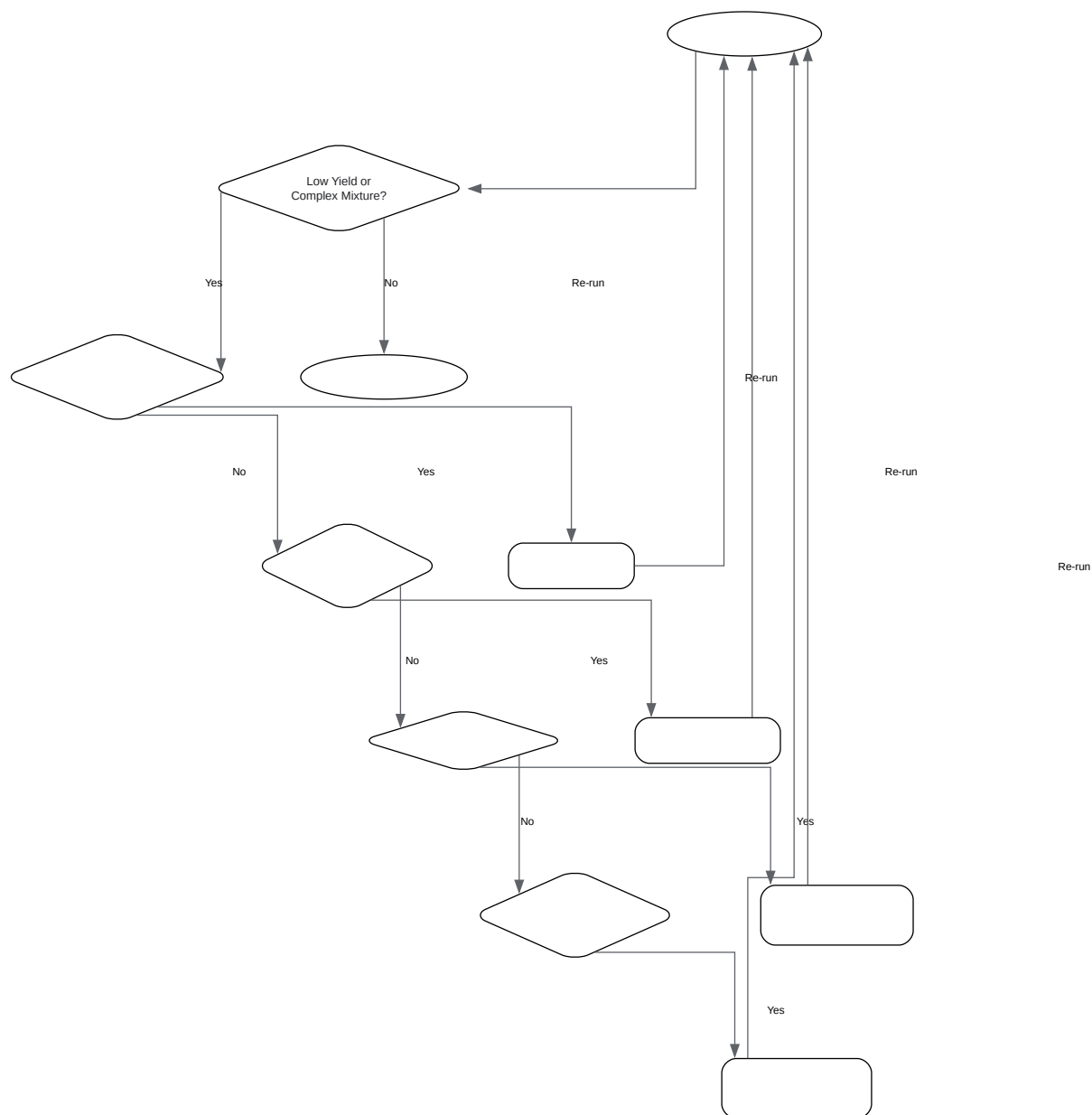

[Click to download full resolution via product page](#)

Caption: Troubleshooting workflow for acid-mediated cyclizations.

Competing Reaction Pathways

This diagram illustrates the competition between the desired first-order intramolecular cyclization and the undesired second-order intermolecular polymerization.

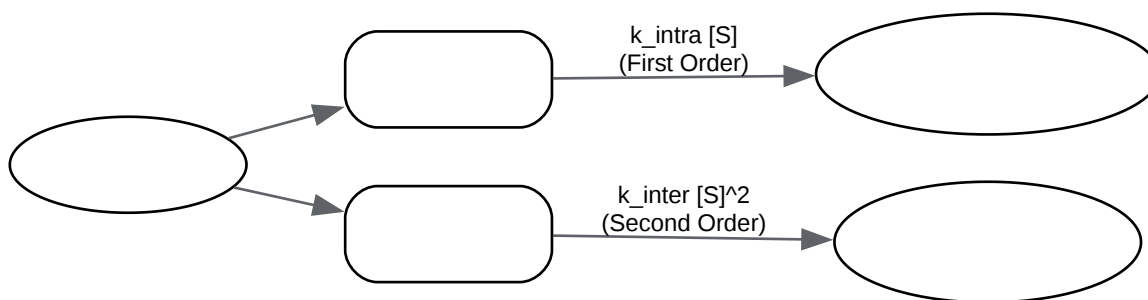

[Click to download full resolution via product page](#)

Caption: Kinetic competition between cyclization and polymerization.

References

- Chemistry Stack Exchange. (2019). Solvent Effects in Friedel–Crafts Reaction. [\[Link\]](#)
- Organic Letters. (2017). Altering the Cyclization Modes: Temperature-Dependent Intramolecular 7-Endo-Dig vs 6-Endo-Dig Electrophilic Ring Closures. [\[Link\]](#)
- ACS Publications. (2009). Process Development and Pilot-Scale Synthesis of New Cyclization Conditions of Substituted Phenylacetamides to Tetrahydroisoquinoline-2-ones Using Eaton's Reagent. [\[Link\]](#)
- Temperature regiocontrol of intramolecular cyclization of di-hydroxysecoacids. (2025). [\[Link\]](#)
- Chemical Reviews. (2021). Catalytic Asymmetric Hydroalkoxylation of C–C Multiple Bonds. [\[Link\]](#)
- RSC Publishing. (2022). P 4 O 10 /TfOH mediated domino condensation–cyclization of amines with diacids: a route to indolizidine alkaloids under catalyst. [\[Link\]](#)

- PMC - NIH. Thermally-Induced Substrate Release Via Intramolecular Cyclizations of Amino Esters and Amino Carbonates. [[Link](#)]
- Organic Reactions. The Nazarov Cyclization. [[Link](#)]
- Organic Syntheses Procedure. Submitted by Qiang Yang, et al. [[Link](#)]
- PMC - NIH. Applications of Friedel–Crafts reactions in total synthesis of natural products. [[Link](#)]
- Wikipedia. Nazarov cyclization reaction. [[Link](#)]
- ResearchGate. The effect of solvent on the conversion and selectivity of the Friedel-Crafts acetylation. [[Link](#)]
- ResearchGate. The Nazarov Cyclization | Request PDF. [[Link](#)]
- IRIS UPO. Approaches to the synthesis of cyclic peptides with inhibitory activity. [[Link](#)]
- Organic Chemistry Portal. Nazarov Cyclization. [[Link](#)]
- PubMed. Effects of temperature on excluded volume-promoted cyclization and concatemerization of cohesive-ended DNA longer than 0.04 Mb. [[Link](#)]
- International Journal of Chemical Studies. (2015). Friedel-Crafts alkylation and acylation of aromatic compounds under solvent free conditions using solid acid catalysts. [[Link](#)]
- Study Mind. Friedel-Crafts Acylation and Alkylation (A-Level Chemistry). [[Link](#)]
- ACS Publications. (2005). Lewis Acid Assisted Ring-Closing Metathesis of Chiral Diallylamines: An Efficient Approach to Enantiopure Pyrrolidine Derivatives. [[Link](#)]
- PMC. (2021). Highly Efficient Cyclization Approach of Propargylated Peptides via Gold(I)-Mediated Sequential C–N, C–O, and C–C Bond Formation. [[Link](#)]
- RSC Publishing. The effects of buffer, pH, and temperature upon SPAAC reaction rates. [[Link](#)]

- Green Chemistry (RSC Publishing). Brønsted acid-catalyzed cascade cyclization: an efficient strategy for divergent synthesis of cyclohepta[b]indole derivatives. [\[Link\]](#)
- ResearchGate. (PDF) A Simple, Selective, and General Catalyst for Ring Closing Depolymerization of Polyesters and Polycarbonates for Chemical Recycling. [\[Link\]](#)
- PMC - NIH. Enzyme-Catalyzed Intramolecular Enantioselective Hydroalkoxylation. [\[Link\]](#)
- Organic Chemistry: A Tenth Edition. 18.5 Reactions of Epoxides: Ring-Opening. [\[Link\]](#)
- Chemistry Stack Exchange. (2013). Regioselectivity of acid-catalyzed ring-opening of epoxides. [\[Link\]](#)
- Patsnap Eureka. (2025). How to Reduce Toxic Byproducts in Carboxylic Acid Reactions? [\[Link\]](#)
- ResearchGate. Investigation of cyclization reaction of 20 in PPA. [\[Link\]](#)
- Chemistry LibreTexts. (2024). 18.6: Reactions of Epoxides - Ring-opening. [\[Link\]](#)
- PMC. A highly efficient and sustainable catalyst system for terminal epoxy-carboxylic acid ring opening reactions. [\[Link\]](#)
- CHIMIA. The Mechanism of the Acid-Catalyzed Ring Opening of Epoxides - A Reinterpretative Review. [\[Link\]](#)
- PMC. Palladium-Catalyzed Oxidative Cyclization of O-Aryl Cyclic Vinylogous Esters: Synthesis of Benzofuran-Fused Cyclohexenones. [\[Link\]](#)
- SciSpace. Mechanistic Analysis of Gold(I)-Catalyzed Intramolecular Allene Hydroalkoxylation Reveals an Off-Cycle Bis. [\[Link\]](#)
- Lumen Learning. 9.6. Epoxide reactions | Organic Chemistry 1: An open textbook. [\[Link\]](#)
- Organic Chemistry. (2019). Acid Catalyze ring opening of Epoxides - HBr, HCl, HI, H2SO4/H2O. [\[Link\]](#)

- SciSpace. Studies on Lewis acid-mediated intramolecular cyclization reactions of allene-ene systems. [[Link](#)]
- The Royal Society of Chemistry. (2014). Intramolecular Hydroalkoxylation Catalyzed inside a Self-assembled Cavity of an Enzyme-like Host Structure. [[Link](#)]
- MDPI. (2021). Earth-Abundant 3d Transition Metal Catalysts for Hydroalkoxylation and Hydroamination of Unactivated Alkenes. [[Link](#)]
- PubMed. (2009). Enantioselective Brønsted Acid-Catalyzed N-acyliminium Cyclization Cascades. [[Link](#)]
- ACID CATALYZED CYCLIZATION REACTION OF 3-HYDRAZONO-1,1,1-. (2005). [[Link](#)]

Need Custom Synthesis?

BenchChem offers custom synthesis for rare earth carbides and specific isotopic labeling.

Email: info@benchchem.com or [Request Quote Online](#).

Sources

- [1. Highly Efficient Cyclization Approach of Propargylated Peptides via Gold\(I\)-Mediated Sequential C–N, C–O, and C–C Bond Formation - PMC \[pmc.ncbi.nlm.nih.gov\]](#)
- [2. BJOC - Recent total synthesis of natural products leveraging a strategy of enamide cyclization \[beilstein-journals.org\]](#)
- [3. pdf.benchchem.com \[pdf.benchchem.com\]](#)
- [4. Buy Eaton's Reagent \(EVT-354210\) | 39394-84-8 \[evitachem.com\]](#)
- [5. pubs.acs.org \[pubs.acs.org\]](#)
- [6. Organic Syntheses Procedure \[orgsyn.org\]](#)
- [7. chemistry.stackexchange.com \[chemistry.stackexchange.com\]](#)
- [8. Altering the Cyclization Modes: Temperature-Dependent Intramolecular 7-Endo-Dig vs 6-Endo-Dig Electrophilic Ring Closures - PubMed \[pubmed.ncbi.nlm.nih.gov\]](#)
- [9. researchgate.net \[researchgate.net\]](#)

- [10. 18.5 Reactions of Epoxides: Ring-Opening – Organic Chemistry: A Tenth Edition – OpenStax adaptation 1 \[ncstate.pressbooks.pub\]](#)
- [11. chem.libretexts.org \[chem.libretexts.org\]](#)
- [12. chimia.ch \[chimia.ch\]](#)
- [13. 9.6. Epoxide reactions | Organic Chemistry 1: An open textbook \[courses.lumenlearning.com\]](#)
- [14. pdf.benchchem.com \[pdf.benchchem.com\]](#)
- [15. P 4 O 10 /TfOH mediated domino condensation–cyclization of amines with diacids: a route to indolizidine alkaloids under catalyst- and solvent-free con ... - RSC Advances \(RSC Publishing\) DOI:10.1039/D2RA02534E \[pubs.rsc.org\]](#)
- [16. pubs.acs.org \[pubs.acs.org\]](#)
- [17. Brønsted acid-catalyzed cascade cyclization: an efficient strategy for divergent synthesis of cyclohepta\[b\]indole derivatives - Green Chemistry \(RSC Publishing\) \[pubs.rsc.org\]](#)
- [18. Enzyme-Catalyzed Intramolecular Enantioselective Hydroalkoxylation - PMC \[pmc.ncbi.nlm.nih.gov\]](#)
- [19. Nazarov cyclization reaction - Wikipedia \[en.wikipedia.org\]](#)
- [20. Nazarov Cyclization \[organic-chemistry.org\]](#)
- [21. Applications of Friedel–Crafts reactions in total synthesis of natural products - PMC \[pmc.ncbi.nlm.nih.gov\]](#)
- [22. studymind.co.uk \[studymind.co.uk\]](#)
- [23. organicreactions.org \[organicreactions.org\]](#)
- [24. Nazarov Cyclization | Thermo Fisher Scientific - TW \[thermofisher.com\]](#)
- [To cite this document: BenchChem. \[Technical Support Center: Acid-Mediated Ring Closure Reactions\]. BenchChem, \[2026\]. \[Online PDF\]. Available at: \[https://www.benchchem.com/product/b15345252/docs#technical-support-center-acid-mediated-ring-closure-reactions\]](#)

Disclaimer & Data Validity:

The information provided in this document is for Research Use Only (RUO) and is strictly not intended for diagnostic or therapeutic procedures. While BenchChem strives to provide accurate protocols, we make no warranties, express or implied, regarding the fitness of this product for every specific experimental setup.

Technical Support: The protocols provided are for reference purposes. Unsure if this reagent suits your experiment?

Need Industrial/Bulk Grade? [Request Custom Synthesis Quote](#)

BenchChem

Our mission is to be the trusted global source of essential and advanced chemicals, empowering scientists and researchers to drive progress in science and industry.

Contact

Address: 3281 E Guasti Rd
Ontario, CA 91761, United States
Phone: (601) 213-4426
Email: info@benchchem.com

[Contact our Ph.D. Support Team for a compatibility check](#)