

Application Notes and Protocols: Flow Chemistry for Handling Unstable Intermediates

Author: BenchChem Technical Support Team. **Date:** May 2026

Compound of Interest

Compound Name: *Tetraphosphorus disulfide*

CAS No.: 12165-70-7

Cat. No.: B15343920

[Get Quote](#)

Introduction: Taming the Transient—A Paradigm Shift in Chemical Synthesis

In the realm of chemical synthesis, the path from reactants to products is often traversed through a landscape populated by fleeting, highly reactive species known as unstable intermediates. These transient molecules, such as organometallics, diazo compounds, and nitronium ions, are pivotal to constructing complex molecular architectures. However, their high energy and short lifetimes present significant challenges in traditional batch-wise synthesis.^[1]^[2]^[3] The accumulation of these intermediates in a batch reactor can lead to uncontrolled exothermic events, side reactions, and even explosive decomposition, posing substantial safety risks and limiting scalability.^[4]^[5]^[6]

Flow chemistry emerges as a transformative technology that fundamentally alters how we handle these challenging chemical entities.^[7]^[8] By conducting reactions in a continuous stream through a microreactor or a packed-bed system, flow chemistry offers unparalleled control over reaction parameters.^[9]^[10] The small reactor volumes and high surface-area-to-volume ratios enable superior heat and mass transfer, effectively mitigating the risks associated with highly exothermic reactions.^[5]^[11]^[12] This paradigm shift allows for the in situ generation

and immediate consumption of unstable intermediates, preventing their accumulation and enabling reactions that were previously deemed too hazardous for practical use.[13][14]

This comprehensive guide delves into the principles and practical applications of flow chemistry for managing unstable intermediates. We will explore specific case studies, provide detailed experimental protocols, and offer insights into the causality behind experimental design, empowering researchers to harness the full potential of this powerful technology.

Organometallic Intermediates: Precision and Safety in C-C Bond Formation

Organometallic reagents, particularly organolithium and Grignard reagents, are workhorses in organic synthesis for forming carbon-carbon bonds. However, their high reactivity and accompanying exothermicity often necessitate cryogenic temperatures (-78 °C or lower) in batch processing to control their reactivity and prevent side reactions.[7][15] Flow chemistry provides a robust solution to safely handle these powerful reagents at more practical temperatures.[16][17]

The Causality Behind Flow Chemistry's Advantage

The enhanced safety and efficiency of handling organometallics in flow stem from several key principles:

- **Superior Heat Transfer:** The high surface-area-to-volume ratio in microreactors allows for rapid dissipation of the heat generated during the formation and reaction of organometallic species. This prevents the formation of hot spots that can lead to decomposition and side reactions.[12][18]
- **Precise Residence Time Control:** Flow reactors enable exact control over the time the unstable organometallic intermediate exists before it is quenched or reacted with the next reagent. This minimizes decomposition and unwanted rearrangements.[19][15]
- **In Situ Generation and Consumption:** Organometallic reagents can be generated on-demand in one part of the flow system and immediately telescoped into the next reaction step, eliminating the need for their isolation and storage.[17][20]

Experimental Protocol: Lithiation and Borylation in Flow

This protocol details the continuous synthesis of a boronic acid via a bromine-lithium exchange, a process that often suffers from side reactions in batch.[\[21\]](#)[\[22\]](#)

Reagents and Equipment:

- Reagent A: Solution of an aryl bromide (1.0 M) in anhydrous THF.
- Reagent B: Solution of n-butyllithium (n-BuLi, 1.6 M) in hexanes.
- Reagent C: Solution of triisopropyl borate (1.2 M) in anhydrous THF.
- Quench Solution: 1 M HCl (aq).
- Flow Chemistry System: A system equipped with at least three pump channels, a T-mixer, a residence time unit (e.g., PFA tubing), and a back-pressure regulator.

Step-by-Step Methodology:

- System Preparation: Purge the entire flow system with an inert gas (e.g., nitrogen or argon) to ensure anhydrous and oxygen-free conditions.
- Reagent Pumping: Pump Reagent A (aryl bromide solution) and Reagent B (n-BuLi solution) at controlled flow rates to a T-mixer. The stoichiometry is controlled by the relative flow rates.
- Lithiation: The mixed stream flows through a residence time unit (e.g., a 10 mL PFA coil) maintained at a specific temperature (e.g., 0 °C). The residence time is determined by the total flow rate and the volume of the coil. A short residence time (e.g., 0.25 seconds) is often sufficient to generate the unstable aryllithium intermediate.[\[21\]](#)
- Borylation: The stream containing the aryllithium intermediate is then mixed with Reagent C (triisopropyl borate solution) at a second T-mixer.
- Quenching: The reaction mixture immediately flows into a stream of the quench solution (1 M HCl) to hydrolyze the boronate ester to the desired boronic acid.
- Collection and Analysis: The product stream is collected, and the yield and purity are determined by standard analytical techniques (e.g., HPLC, NMR).

Workflow Diagram

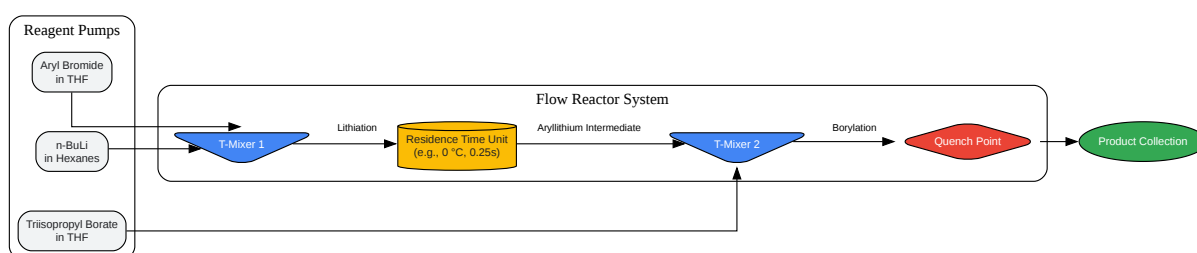

[Click to download full resolution via product page](#)

Caption: Workflow for continuous lithiation and borylation.

Data Summary

Intermediate Type	Reaction	Batch Conditions	Flow Conditions	Key Advantage in Flow
Aryllithium	Lithiation-Borylation	-78 °C, slow addition	0 °C, 0.25s residence time	Suppression of side reactions, improved safety. [21][22]
Grignard Reagent	C(sp ²)-C(sp ³) Coupling	Batch generation and use	On-demand generation in packed-bed	Enables library synthesis, avoids storage of reactive reagents. [20]

Diazomethane: On-Demand Generation for Safe Methylations and Cyclopropanations

Diazomethane (CH_2N_2) is a highly versatile reagent for methylation and cyclopropanation reactions. However, it is also a toxic, carcinogenic, and explosive gas, making its handling in batch, especially on a large scale, extremely hazardous.^{[18][23][24]} Flow chemistry provides a safe and scalable solution by enabling the on-demand, in situ generation and immediate consumption of diazomethane, ensuring that only small quantities are present at any given time.^{[24][25][26]}

The Causality Behind Flow Chemistry's Advantage

- **Minimized Inventory:** The core safety principle is the continuous generation and immediate use of diazomethane, keeping the amount of this hazardous substance in the system to a minimum (often below a few grams).^{[18][23]}
- **Containment:** The entire process occurs within a closed and contained flow system, minimizing operator exposure to the toxic gas.
- **Controlled Stoichiometry:** Precise control over the flow rates of precursors and substrates ensures efficient consumption of the generated diazomethane, preventing its accumulation.

Experimental Protocol: Continuous Generation and Consumption of Diazomethane

This protocol describes a two-step flow process for the generation of diazomethane from N-methyl-N-nitrosourea (MNU), which itself is generated in situ from non-hazardous N-methylurea.^[25]

Reagents and Equipment:

- **Reagent A:** Aqueous solution of N-methylurea and sodium nitrite.
- **Reagent B:** Aqueous sulfuric acid.
- **Reagent C:** Aqueous potassium hydroxide.

- **Substrate Stream:** Substrate (e.g., a carboxylic acid) dissolved in a suitable organic solvent.
- **Flow Chemistry System:** A multi-stage system with pumps, reactors (coils or packed beds), and a gas-liquid separator or a membrane separator. A tube-in-tube reactor with a gas-permeable membrane (e.g., Teflon AF-2400) is particularly effective.[26]

Step-by-Step Methodology:

- **MNU Generation:** Pump Reagent A and Reagent B into a first reactor coil to generate the unstable intermediate N-methyl-N-nitrosourea (MNU).
- **Diazomethane Generation:** The MNU stream is then mixed with Reagent C (aqueous KOH) in a second reactor to generate diazomethane.
- **Gas-Liquid Separation:** The resulting stream, containing diazomethane in an organic/aqueous mixture, is passed through a membrane separator. The gaseous diazomethane diffuses through the membrane into a separate stream containing the substrate dissolved in an organic solvent.[26]
- **Reaction:** The diazomethane-containing substrate stream flows through a final reactor coil (which can be heated or cooled as required by the specific reaction) to form the product.
- **Quenching (Optional but Recommended):** A small amount of acetic acid can be introduced into the product stream to quench any unreacted diazomethane.
- **Collection:** The final product is collected for analysis and purification.

Workflow Diagram

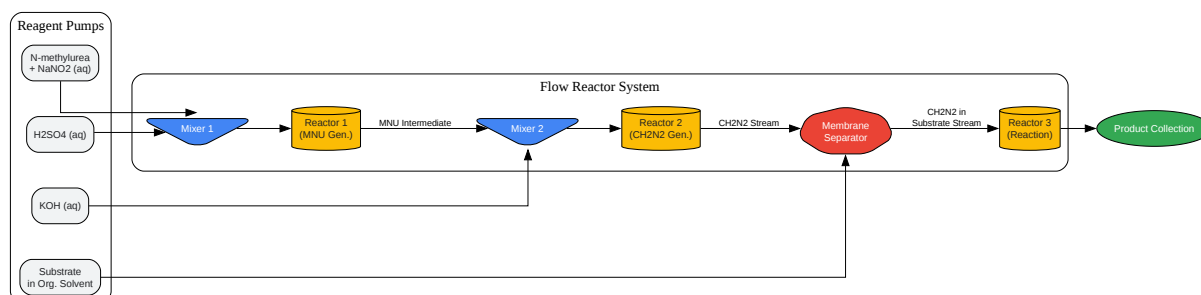

[Click to download full resolution via product page](#)

Caption: On-demand generation and use of diazomethane in flow.

Nitration Reactions: Mastering Exothermic Processes

Nitration is a fundamental transformation in organic chemistry, but it is notoriously hazardous due to the use of highly corrosive and oxidizing strong acids and the strongly exothermic nature of the reaction.[27][28] In batch processing, poor heat dissipation can lead to thermal runaways, over-nitration, and the formation of explosive byproducts.[6][28] Flow chemistry offers a significantly safer and more efficient alternative for conducting nitration reactions.[11]

The Causality Behind Flow Chemistry's Advantage

- Isothermal Control: The excellent heat transfer capabilities of flow reactors allow for precise temperature control, preventing hot spots and ensuring the reaction proceeds under optimal, isothermal conditions.[7][11]

- **Reduced Reaction Volume:** The small volume of the reacting mixture at any given time drastically reduces the potential energy of a thermal runaway, making the process inherently safer.[5][6][11]
- **Enhanced Mixing:** Rapid and efficient mixing of the organic substrate and the nitrating agent in microreactors leads to improved reaction rates and selectivity, minimizing the formation of unwanted byproducts.[9]

Experimental Protocol: Continuous Nitration of an Aromatic Compound

This protocol outlines a general procedure for the continuous nitration of an aromatic substrate using a mixed acid system.

Reagents and Equipment:

- **Reagent A:** Aromatic substrate dissolved in a suitable solvent (e.g., dichloromethane or sulfuric acid).
- **Reagent B:** Nitrating mixture (e.g., a pre-mixed and cooled solution of nitric acid and sulfuric acid).
- **Flow Chemistry System:** A system with at least two pumps, a T-mixer, and a temperature-controlled residence time unit. The materials of construction must be resistant to strong acids (e.g., PFA, Hastelloy).

Step-by-Step Methodology:

- **System Preparation:** Ensure the flow system is clean, dry, and compatible with the corrosive reagents.
- **Reagent Pumping:** Pump the substrate solution (Reagent A) and the nitrating mixture (Reagent B) through separate channels to a T-mixer. The pumps should be capable of handling corrosive fluids.
- **Mixing and Reaction:** The reagents are rapidly mixed and enter a temperature-controlled reactor coil. The temperature is precisely maintained to control the reaction rate and selectivity.

- Residence Time: The reaction mixture flows through the coil for a defined residence time, sufficient for the reaction to reach completion.
- Quenching: The product stream is continuously quenched by mixing it with a stream of cold water or a basic solution to neutralize the strong acids.
- Collection and Work-up: The quenched mixture is collected for subsequent extraction, purification, and analysis.

Workflow Diagram

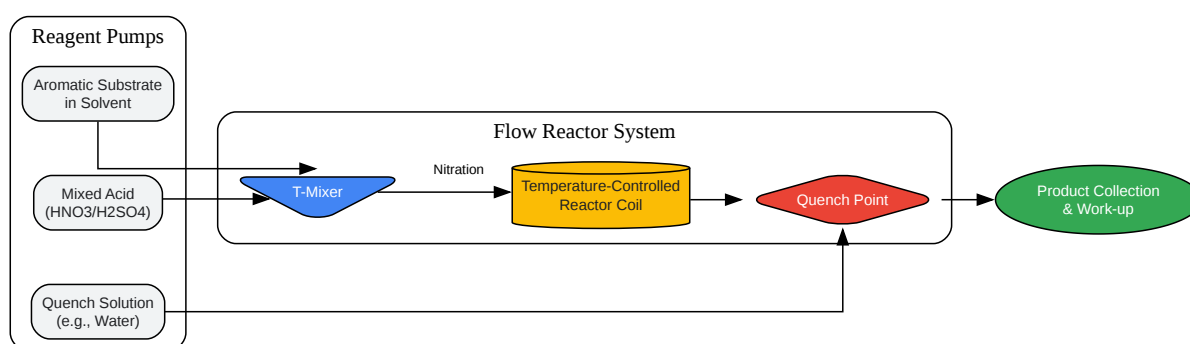

[Click to download full resolution via product page](#)

Caption: Continuous flow nitration of an aromatic compound.

Data Summary

Reaction Type	Key Hazard	Batch Challenges	Flow Solution	Key Advantage in Flow
Nitration	Highly Exothermic, Corrosive Reagents	Thermal runaway, over-nitration, safety risks.[28]	Precise temperature control, small reaction volume. [11]	Enhanced safety, improved selectivity, higher yields.[28]
Diazotization	Unstable Diazonium Salts	Accumulation of explosive intermediates.	In-situ generation and immediate consumption.	Prevents isolation of hazardous diazonium salts.
Ozonolysis	Explosive Ozonides	Accumulation of unstable ozonide intermediates.	Continuous generation and quenching of ozonides.	Safe handling of a highly energetic reaction.

Conclusion: A Safer, More Efficient Future for Chemistry

Flow chemistry represents a fundamental advancement in our ability to safely and efficiently handle unstable intermediates.[9][29] By leveraging principles of superior heat and mass transfer, precise residence time control, and in situ reagent generation, this technology transforms hazardous and challenging reactions into manageable and scalable processes.[5][10][30] The protocols and principles outlined in this guide provide a foundation for researchers, scientists, and drug development professionals to explore the vast potential of flow chemistry. As the field continues to evolve, the adoption of continuous processing will undoubtedly lead to new discoveries and innovations, paving the way for a safer, more efficient, and sustainable future for chemical synthesis.

References

- Gemoets, H. P. L. et al. (2016). A scalable and safe continuous flow procedure for in-line generation of diazomethane and its precursor MNU. Green Chemistry. Available at: [\[Link\]](#)

- Movsisyan, M. et al. (2016). Taming hazardous chemistry by continuous flow technology. *Chemical Society Reviews*. Available at: [\[Link\]](#)
- Chen, Y. et al. (2023). Continuous-flow-enabled intensification in nitration processes: a review of technological developments and practical applications over the past decade. *Beilstein Journal of Organic Chemistry*. Available at: [\[Link\]](#)
- Pastre, J. C. et al. (2015). Flow Chemistry: Recent Developments in the Synthesis of Pharmaceutical Products. *ACS Medicinal Chemistry Letters*. Available at: [\[Link\]](#)
- NJ Bio, Inc. Flow Chemistry. Available at: [\[Link\]](#)
- Pharmaceutical Technology. (2017). Hazardous Chemistry: Choosing Batch or Flow. Available at: [\[Link\]](#)
- Mettler Toledo. Benefits of Continuous Flow Chemistry. Available at: [\[Link\]](#)
- Mastronardi, F. et al. (2013). Continuous Flow Generation and Reactions of Anhydrous Diazomethane Using a Teflon AF-2400 Tube-in-Tube Reactor. *Organic Letters*. Available at: [\[Link\]](#)
- Yoshida, J. et al. (2012). Flow Chemistry Processes for Reactions Utilizing Unstable Intermediates: Applications Toward Pharmaceutical Production. *Journal of Flow Chemistry*. Available at: [\[Link\]](#)
- Maddox, D. et al. (2024). Enabling organometallic libraries by flow: a tale of two metals. *Reaction Chemistry & Engineering*. Available at: [\[Link\]](#)
- IOP Conference Series: Earth and Environmental Science. (2023). Nitration and flow chemistry. Available at: [\[Link\]](#)
- ResearchGate. (2016). Taming Hazardous Chemistry by Continuous Flow Technology. Available at: [\[Link\]](#)
- Noël, T. et al. (2021). A field guide to flow chemistry for synthetic organic chemists. *Nature Communications*. Available at: [\[Link\]](#)

- ResearchGate. (2018). Safely scaling hazardous chemistry through continuous flow technology. Available at: [\[Link\]](#)
- LinkedIn. (2024). Efficiency and Safety: Transforming Chemical Processes with Flow Chemistry. Available at: [\[Link\]](#)
- Semantic Scholar. (2023). Nitration and flow chemistry. Available at: [\[Link\]](#)
- Vapourtec. Nitration Reactions | Continuous Flow Processing. Available at: [\[Link\]](#)
- Synfacts. (2021). Safer Handling of Diazomethane through Continuous Generation and Consumption. Available at: [\[Link\]](#)
- Amar Equipment. (2024). Flow Chemistry: Revolutionizing the Safeguarding of Energetic Materials Production. Available at: [\[Link\]](#)
- Wikipedia. Diazomethane. Available at: [\[Link\]](#)
- Britton, J. et al. (2020). How to approach flow chemistry. Chemical Society Reviews. Available at: [\[Link\]](#)
- Interchim – Blog. (2017). Processing unstable intermediates with Flow Chemistry. Available at: [\[Link\]](#)
- CHEManager Online. (2011). Flow Chemistry for Hazardous Reactions. Available at: [\[Link\]](#)
- Vapourtec. (2018). Safe Use of Hazardous Chemicals in Flow. Available at: [\[Link\]](#)
- Sai Life Sciences. Flow Chemistry & Continuous Processing. Available at: [\[Link\]](#)
- Vapourtec. Advantages of continuous flow production. Available at: [\[Link\]](#)
- MDPI. (2020). Micromixing and Co-Precipitation in Continuous Microreactors with Swirled Flows and Microreactors with Impinging Swirled Flows. Available at: [\[Link\]](#)
- Semantic Scholar. (2016). Figure 1 from Taming hazardous chemistry by continuous flow technology. Available at: [\[Link\]](#)

- National Institutes of Health. (2022). Understanding flow chemistry for the production of active pharmaceutical ingredients. Available at: [\[Link\]](#)
- ResearchGate. (2018). Effective Utilization of Flow Chemistry: Use of Unstable Intermediates, Inhibition of Side Reactions, and Scale-Up for Boronic Acid Synthesis. Available at: [\[Link\]](#)
- ACS Publications. (2020). The Concept of Chemical Generators: On-Site On-Demand Production of Hazardous Reagents in Continuous Flow. Available at: [\[Link\]](#)
- Organic Process Research & Development. (2018). Effective Utilization of Flow Chemistry: Use of Unstable Intermediates, Inhibition of Side Reactions, and Scale-Up for Boronic Acid Synthesis. Available at: [\[Link\]](#)
- Fraunhofer IMM. (2022). Organometallics in Flow. Available at: [\[Link\]](#)
- National Institutes of Health. (2020). The Concept of Chemical Generators: On-Site On-Demand Production of Hazardous Reagents in Continuous Flow. Available at: [\[Link\]](#)
- ResearchGate. (2022). (PDF) Understanding Flow Chemistry for the Production of Active Pharmaceutical Ingredients. Available at: [\[Link\]](#)
- ResearchGate. (2019). Principle of generation and reaction of unstable short-lived reactive intermediates based on residence time control in a flow microreactor. Available at: [\[Link\]](#)
- YouTube. (2024). How Do Chemists Detect Unstable Reaction Intermediates?. Available at: [\[Link\]](#)
- ResearchGate. (2020). (PDF) The Concept of Chemical Generators: On-Site On-Demand Production of Hazardous Reagents in Continuous Flow. Available at: [\[Link\]](#)
- DSpace@MIT. (2018). Enabling the use of unstable, hazardous reagents with continuous flow synthesis. Available at: [\[Link\]](#)
- YouTube. (2024). What Techniques Are Used To Characterize Unstable Intermediates?. Available at: [\[Link\]](#)

- YouTube. (2024). Why Are Reaction Intermediates Unstable Species?. Available at: [\[Link\]](#)
- YouTube. (2024). Are All Reaction Intermediates Highly Unstable?. Available at: [\[Link\]](#)

Need Custom Synthesis?

BenchChem offers custom synthesis for rare earth carbides and specific isotopic labeling.

Email: info@benchchem.com or [Request Quote Online](#).

Sources

- 1. youtube.com [youtube.com]
- 2. youtube.com [youtube.com]
- 3. youtube.com [youtube.com]
- 4. pharmtech.com [pharmtech.com]
- 5. comchart.com [comchart.com]
- 6. amarequip.com [amarequip.com]
- 7. A field guide to flow chemistry for synthetic organic chemists - PMC [[pmc.ncbi.nlm.nih.gov](https://pubmed.ncbi.nlm.nih.gov)]
- 8. Flow Chemistry for Hazardous Reactions • CHEManager is the market-leading medium for the management of the chemical and pharmaceutical industry [chemanager-online.com]
- 9. Taming hazardous chemistry by continuous flow technology - Chemical Society Reviews (RSC Publishing) [pubs.rsc.org]
- 10. mt.com [mt.com]
- 11. BJOC - Continuous-flow-enabled intensification in nitration processes: a review of technological developments and practical applications over the past decade [beilstein-journals.org]
- 12. vapourtec.com [vapourtec.com]
- 13. The Concept of Chemical Generators: On-Site On-Demand Production of Hazardous Reagents in Continuous Flow - PMC [[pmc.ncbi.nlm.nih.gov](https://pubmed.ncbi.nlm.nih.gov)]
- 14. researchgate.net [researchgate.net]
- 15. ousar.lib.okayama-u.ac.jp [ousar.lib.okayama-u.ac.jp]
- 16. pubs.acs.org [pubs.acs.org]

- [17. How to approach flow chemistry - Chemical Society Reviews \(RSC Publishing\)](#) [DOI:10.1039/C9CS00832B] [[pubs.rsc.org](#)]
- [18. njbio.com](#) [[njbio.com](#)]
- [19. Understanding flow chemistry for the production of active pharmaceutical ingredients - PMC](#) [[pmc.ncbi.nlm.nih.gov](#)]
- [20. Enabling organometallic libraries by flow: a tale of two metals - Reaction Chemistry & Engineering \(RSC Publishing\)](#) [[pubs.rsc.org](#)]
- [21. researchgate.net](#) [[researchgate.net](#)]
- [22. Effective Utilization of Flow Chemistry: Use of Unstable Intermediates, Inhibition of Side Reactions, and Scale-Up for Boronic Acid Synthesis | Semantic Scholar](#) [[semanticscholar.org](#)]
- [23. Thieme E-Journals - Synfacts / Abstract](#) [[thieme-connect.com](#)]
- [24. Diazomethane - Wikipedia](#) [[en.wikipedia.org](#)]
- [25. A scalable and safe continuous flow procedure for in-line generation of diazomethane and its precursor MNU - Green Chemistry \(RSC Publishing\)](#) [[pubs.rsc.org](#)]
- [26. pubs.acs.org](#) [[pubs.acs.org](#)]
- [27. pdfs.semanticscholar.org](#) [[pdfs.semanticscholar.org](#)]
- [28. vapourtec.com](#) [[vapourtec.com](#)]
- [29. researchgate.net](#) [[researchgate.net](#)]
- [30. researchgate.net](#) [[researchgate.net](#)]
- To cite this document: BenchChem. [Application Notes and Protocols: Flow Chemistry for Handling Unstable Intermediates]. BenchChem, [2026]. [Online PDF]. Available at: [<https://www.benchchem.com/product/b15343920/docs#application-notes-and-protocols-flow-chemistry-for-handling-unstable-intermediates>]

Disclaimer & Data Validity:

The information provided in this document is for Research Use Only (RUO) and is strictly not intended for diagnostic or therapeutic procedures. While BenchChem strives to provide accurate protocols, we make no warranties, express or implied, regarding the fitness of this product for every specific experimental setup.

Technical Support: The protocols provided are for reference purposes. Unsure if this reagent suits your experiment?

Need Industrial/Bulk Grade? [Request Custom Synthesis Quote](#)

BenchChem

Our mission is to be the trusted global source of essential and advanced chemicals, empowering scientists and researchers to drive progress in science and industry.

Contact

Address: 3281 E Guasti Rd
Ontario, CA 91761, United States
Phone: (601) 213-4426
Email: info@benchchem.com

[Contact our Ph.D. Support Team for a compatibility check](#)