

Application Note: Characterization of 1,3-Diethylcyclohexane Isomers using NMR Spectroscopy

Author: BenchChem Technical Support Team. **Date:** May 2026

Compound of Interest

Compound Name: 1,3-Diethylcyclohexane

CAS No.: 1678-99-5

Cat. No.: B15342211

[Get Quote](#)

Introduction

1,3-Diethylcyclohexane exists as two distinct geometric isomers: **cis-1,3-diethylcyclohexane** and **trans-1,3-diethylcyclohexane**. The spatial arrangement of the two ethyl groups relative to the cyclohexane ring significantly influences their physical, chemical, and spectroscopic properties. Nuclear Magnetic Resonance (NMR) spectroscopy is a powerful, non-destructive analytical technique that provides detailed information about molecular structure, making it an ideal tool for the unambiguous differentiation and characterization of these isomers. This application note provides a comprehensive overview of the application of one-dimensional (^1H and ^{13}C) and two-dimensional (COSY, HSQC, and HMBC) NMR experiments for the structural elucidation of **cis-** and **trans-1,3-diethylcyclohexane**. Detailed experimental protocols are provided to guide researchers in acquiring high-quality NMR data for these and similar small molecules.

Conformational Analysis

The stereochemical differences between the cis and trans isomers of **1,3-diethylcyclohexane** lead to distinct conformational preferences, which are reflected in their NMR spectra.

- **cis-1,3-Diethylcyclohexane**: In its most stable chair conformation, both ethyl groups can occupy equatorial positions to minimize steric hindrance. This results in a molecule with a plane of symmetry, simplifying the NMR spectrum. Due to rapid chair-flipping at room temperature, certain protons and carbons become chemically equivalent on the NMR timescale.
- **trans-1,3-Diethylcyclohexane**: In the chair conformation, one ethyl group must be in an axial position while the other is in an equatorial position. Through ring inversion, the axial and equatorial positions of the ethyl groups are interchanged. At room temperature, this rapid interconversion leads to an averaged spectrum.

The differences in symmetry and the steric environments of the nuclei in the preferred conformations of the cis and trans isomers result in unique sets of chemical shifts and coupling constants, allowing for their clear differentiation by NMR.

Predicted NMR Data

Due to the limited availability of experimental NMR data for **1,3-diethylcyclohexane** isomers in publicly accessible databases, the following ^1H and ^{13}C NMR chemical shifts have been generated using a reliable online NMR prediction tool. This data provides a strong basis for the identification and assignment of the signals for each isomer.

Predicted ^1H NMR Data

Isomer	Atom	Predicted Chemical Shift (ppm)	Predicted Multiplicity	Predicted Coupling Constant (J, Hz)
cis-1,3-Diethylcyclohexane	H-1, H-3	1.25	m	-
	H-2a, H-2e	1.70, 1.15	m	-
	H-4a, H-4e	1.75, 1.20	m	-
	H-5a, H-5e	1.30, 1.30	m	-
	H-6a, H-6e	1.75, 1.20	m	-
	CH ₂ (ethyl)	1.35	q	7.4
	CH ₃ (ethyl)	0.88	t	7.4
trans-1,3-Diethylcyclohexane	H-1	1.30	m	-
	H-2a, H-2e	1.80, 1.10	m	-
	H-3	1.30	m	-
	H-4a, H-4e	1.78, 1.18	m	-
	H-5a, H-5e	1.35, 1.35	m	-
	H-6a, H-6e	1.78, 1.18	m	-
	CH ₂ (ethyl, eq)	1.40	q	7.5
	CH ₃ (ethyl, eq)	0.90	t	7.5
	CH ₂ (ethyl, ax)	1.20	q	7.3
CH ₃ (ethyl, ax)	0.85	t	7.3	

Note: 'a' denotes axial and 'e' denotes equatorial protons. Multiplicities are denoted as s (singlet), d (doublet), t (triplet), q (quartet), and m (multiplet).

Predicted ^{13}C NMR Data

Isomer	Atom	Predicted Chemical Shift (ppm)
cis-1,3-Diethylcyclohexane	C-1, C-3	35.5
	C-2	30.0
	C-4, C-6	43.0
	C-5	26.5
	CH ₂ (ethyl)	28.5
	CH ₃ (ethyl)	11.0
	trans-1,3-Diethylcyclohexane	C-1
C-2		27.5
C-3		33.0
C-4, C-6		40.5
C-5		24.0
CH ₂ (ethyl, eq)		29.0
CH ₃ (ethyl, eq)		11.5
CH ₂ (ethyl, ax)		26.0
CH ₃ (ethyl, ax)	10.5	

Experimental Protocols

The following protocols provide a general framework for the NMR analysis of **1,3-diethylcyclohexane** isomers. Instrument-specific parameters may require optimization.

Sample Preparation

- **Sample Purity:** Ensure the sample of **1,3-diethylcyclohexane** is of high purity to avoid signals from contaminants.
- **Solvent Selection:** Choose a deuterated solvent that readily dissolves the sample. Deuterated chloroform (CDCl_3) is a common choice for non-polar compounds.
- **Concentration:** For ^1H NMR, prepare a solution of approximately 5-10 mg of the compound in 0.6-0.7 mL of the deuterated solvent. For ^{13}C NMR and 2D experiments, a more concentrated solution of 20-50 mg in the same volume is recommended.
- **Sample Filtration:** To remove any particulate matter, filter the sample solution through a small plug of glass wool in a Pasteur pipette directly into a clean, dry 5 mm NMR tube.
- **Internal Standard:** Tetramethylsilane (TMS) is commonly used as an internal standard for referencing the chemical shifts to 0.00 ppm. However, for routine analysis, the residual solvent peak can often be used as a secondary reference (e.g., CDCl_3 at 7.26 ppm for ^1H NMR and 77.16 ppm for ^{13}C NMR).

1D NMR Spectroscopy

- **Instrument Setup:** Tune and shim the spectrometer to achieve optimal magnetic field homogeneity.
- **Acquisition Parameters:**
 - **Pulse Sequence:** A standard single-pulse sequence (e.g., zg30 on Bruker instruments).
 - **Spectral Width:** Typically 12-16 ppm, centered around 5-6 ppm.
 - **Acquisition Time:** 2-4 seconds.
 - **Relaxation Delay:** 1-5 seconds.
 - **Number of Scans:** 8-16 scans for a moderately concentrated sample.
- **Processing:** Apply a Fourier transform to the Free Induction Decay (FID), followed by phase correction and baseline correction. Calibrate the spectrum using the TMS or residual solvent signal.

- Instrument Setup: Tune the carbon channel and shim the spectrometer.
- Acquisition Parameters:
 - Pulse Sequence: A standard proton-decoupled pulse sequence (e.g., zgpg30 on Bruker instruments).
 - Spectral Width: Typically 200-240 ppm, centered around 100-120 ppm.
 - Acquisition Time: 1-2 seconds.
 - Relaxation Delay: 2-5 seconds.
 - Number of Scans: 256-1024 scans, depending on the sample concentration.
- Processing: Apply a Fourier transform with an exponential window function, followed by phase and baseline correction. Reference the spectrum.

2D NMR Spectroscopy

- Purpose: To identify proton-proton (^1H - ^1H) spin-spin coupling networks.
- Acquisition:
 - Pulse Sequence: cosygpqf or similar gradient-selected sequence.
 - Spectral Width: Set identical spectral widths in both F2 and F1 dimensions, covering the entire proton chemical shift range.
 - Data Points: 1024-2048 points in F2 and 256-512 increments in F1.
 - Number of Scans: 2-8 scans per increment.
- Processing: Apply a sine-bell window function in both dimensions followed by a 2D Fourier transform. Symmetrize the spectrum if necessary.
- Purpose: To identify direct one-bond proton-carbon (^1H - ^{13}C) correlations.
- Acquisition:

- Pulse Sequence: hsqcedetgpsisp2.3 or a similar edited HSQC sequence to differentiate CH/CH₃ and CH₂ signals.
- Spectral Width: F2 (¹H) dimension should cover the proton spectral range, and F1 (¹³C) should cover the carbon spectral range.
- Data Points: 1024-2048 points in F2 and 128-256 increments in F1.
- Number of Scans: 4-16 scans per increment.
- Processing: Apply appropriate window functions (e.g., sine-bell in F2 and squared sine-bell in F1) and perform a 2D Fourier transform.
- Purpose: To identify long-range (typically 2-3 bond) proton-carbon (¹H-¹³C) correlations.
- Acquisition:
 - Pulse Sequence: hmbcgplpndqf or similar.
 - Spectral Width: Similar to HSQC, covering both proton and carbon chemical shift ranges.
 - Data Points: 1024-2048 points in F2 and 256-512 increments in F1.
 - Number of Scans: 8-32 scans per increment.
 - Long-Range Coupling Delay: Optimized for an average long-range J-coupling of 8 Hz.
- Processing: Apply appropriate window functions and perform a 2D Fourier transform.

Data Interpretation and Isomer Differentiation

The combination of 1D and 2D NMR data allows for the complete assignment of all proton and carbon signals for each isomer and their unambiguous differentiation.

- Number of Signals: Due to its C_s symmetry, the diequatorial conformer of **cis-1,3-diethylcyclohexane** is expected to show a smaller number of unique ¹³C signals compared to the less symmetric trans isomer where all carbons might be inequivalent in a static conformation. However, due to rapid ring flipping at room temperature, the trans isomer also

shows a simplified spectrum. The key difference will lie in the chemical shifts of the corresponding carbons.

- **Chemical Shifts:** The axial and equatorial ethyl groups in the trans isomer will experience different shielding effects, leading to distinct chemical shifts for their CH₂ and CH₃ groups. In the cis isomer, with both ethyl groups being equatorial, only one set of ethyl signals is expected.
- **COSY:** This experiment will confirm the connectivity within the ethyl groups (CH₂ to CH₃) and within the cyclohexane ring (e.g., H-1 to H-2 and H-6).
- **HSQC:** This will directly link each proton to its attached carbon, facilitating the assignment of the carbon spectrum based on the more easily assigned proton spectrum.
- **HMBC:** This experiment is crucial for confirming the overall carbon skeleton. For example, correlations from the ethyl CH₂ protons to C-1 and C-3 of the cyclohexane ring, and from the ring protons to the ethyl carbons, will solidify the structural assignment.

Visualization of Experimental Workflow and Logic

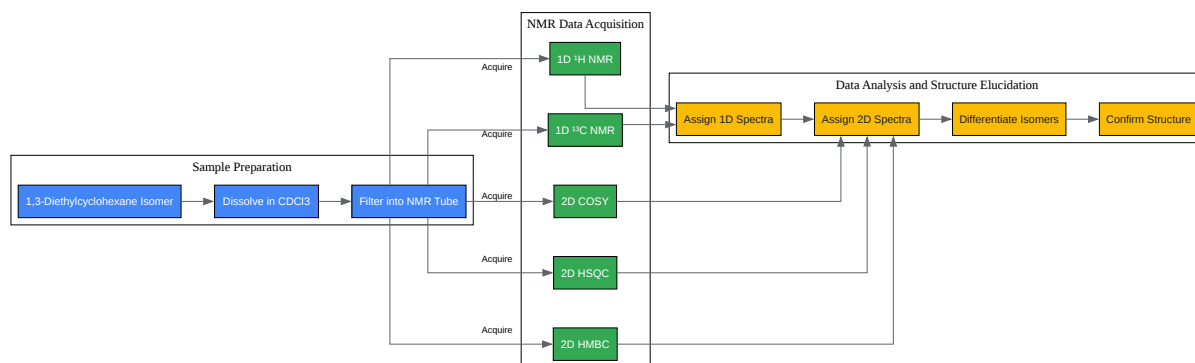

[Click to download full resolution via product page](#)

Caption: Experimental workflow for the NMR characterization of **1,3-diethylcyclohexane** isomers.

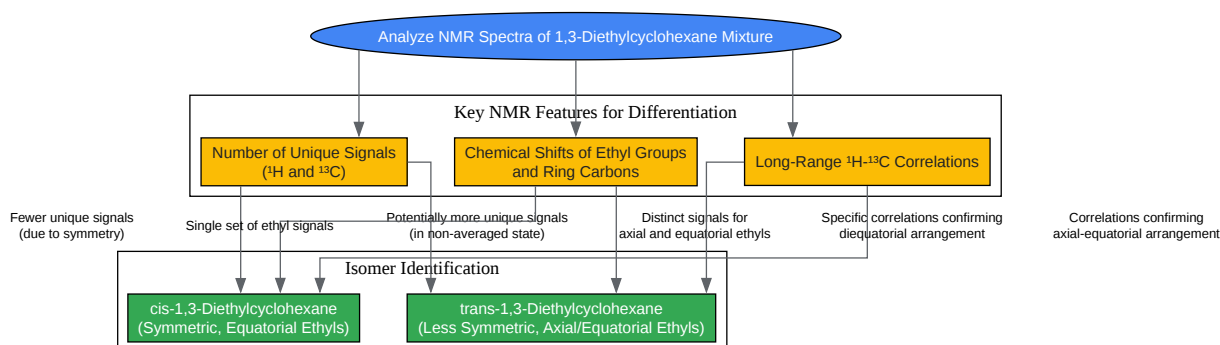

[Click to download full resolution via product page](#)

Caption: Logical workflow for differentiating cis and trans isomers based on NMR data.

Conclusion

NMR spectroscopy, through a combination of 1D and 2D experiments, provides a robust and definitive method for the characterization and differentiation of cis- and trans-**1,3-diethylcyclohexane** isomers. The distinct stereochemistry of these isomers leads to unique NMR spectral features, including the number of signals and specific chemical shifts, which can be fully assigned using COSY, HSQC, and HMBC experiments. The protocols and predicted data presented in this application note serve as a valuable resource for researchers in organic chemistry, drug development, and related fields for the structural elucidation of substituted cyclohexanes and other small organic molecules.

- To cite this document: BenchChem. [Application Note: Characterization of 1,3-Diethylcyclohexane Isomers using NMR Spectroscopy]. BenchChem, [2026]. [Online PDF]. Available at: [<https://www.benchchem.com/product/b15342211/docs#application-note-characterization-of-1-3-diethylcyclohexane-isomers-using-nmr-spectroscopy>]

Disclaimer & Data Validity:

The information provided in this document is for Research Use Only (RUO) and is strictly not intended for diagnostic or therapeutic procedures. While BenchChem strives to provide accurate protocols, we make no warranties, express or implied, regarding the fitness of this product for every specific experimental setup.

Technical Support: The protocols provided are for reference purposes. Unsure if this reagent suits your experiment?

Need Industrial/Bulk Grade? [Request Custom Synthesis Quote](#)

BenchChem

Our mission is to be the trusted global source of essential and advanced chemicals, empowering scientists and researchers to drive progress in science and industry.

Contact

Address: 3281 E Guasti Rd
Ontario, CA 91761, United States
Phone: (601) 213-4426
Email: info@benchchem.com

[Contact our Ph.D. Support Team for a compatibility check](#)