

Technical Support Center: N-Boc Protection & Deprotection

Author: BenchChem Technical Support Team. **Date:** April 2026

Compound of Interest

Compound Name: *2-(1-Boc-4-piperidyl)-4-Cbz-morpholine*

Cat. No.: *B15335827*

[Get Quote](#)

Welcome to the technical support center for N-Boc protection and deprotection. This guide is designed for researchers, scientists, and drug development professionals who utilize the tert-butoxycarbonyl (Boc) protecting group in their synthetic workflows. Here, we address common challenges through a series of in-depth troubleshooting guides and frequently asked questions, grounded in mechanistic principles and field-proven solutions.

Part 1: Troubleshooting N-Boc Protection

The N-Boc protection of amines is a cornerstone of modern organic synthesis, valued for its reliability. However, even this robust reaction can present challenges. This section addresses common issues encountered during the protection step.

Frequently Asked Questions (FAQs): N-Boc Protection

Q1: My N-Boc protection reaction is sluggish or incomplete. What are the likely causes?

Several factors can impede the progress of an N-Boc protection reaction, leading to low conversion rates.^{[1][2]}

- **Low Nucleophilicity of the Amine:** The inherent reactivity of the amine is critical. Sterically hindered amines or electron-deficient amines (e.g., anilines with electron-withdrawing groups) are less nucleophilic and will react more slowly with di-tert-butyl dicarbonate (Boc_2O).^{[1][3]}
- **Poor Solubility:** The starting amine, particularly zwitterionic compounds like amino acids, may have limited solubility in common organic solvents, leading to a heterogeneous reaction mixture and incomplete conversion.^{[1][4]}
- **Inappropriate Base or Stoichiometry:** While not always mandatory, a base is often used to neutralize acidic byproducts and accelerate the reaction.^[5] An incorrect choice of base or insufficient equivalents can stall the reaction.
- **Hydrolysis of Boc Anhydride:** Boc_2O can be hydrolyzed by water. In aqueous systems, if the rate of aminolysis is not significantly faster, this side reaction can consume the reagent and reduce yields.^[1]

Q2: How can I improve the yield for a poorly reactive amine?

For amines that are sterically hindered or electronically deactivated, several strategies can be employed:

- **Increase Temperature:** Gently heating the reaction can increase the rate. However, be aware that Boc_2O can decompose at elevated temperatures.^[1]
- **Use a Catalyst:** The addition of a nucleophilic catalyst, such as 4-(dimethylamino)pyridine (DMAP), can significantly accelerate the reaction by activating the Boc anhydride.^[1]
- **Solvent Choice:** Using solvents like 1,1,1,3,3,3-hexafluoroisopropanol (HFIP) or methanol can enhance the reaction rate, sometimes even without a base.^{[1][6]}
- **Alternative Reagents:** For particularly challenging cases, more reactive Boc-donating reagents, such as Boc-ON, can be considered.^[5]

Q3: I'm working with an amino acid and facing solubility issues. What is the best approach?

Amino acids are zwitterionic and often poorly soluble in standard organic solvents.[1][4] To overcome this:

- **Aqueous Basic Conditions:** Dissolve the amino acid in an aqueous solution of a base like sodium hydroxide (NaOH) or sodium bicarbonate (NaHCO₃). This deprotonates the ammonium group, forming a more soluble carboxylate salt that reacts readily with Boc₂O.[1]
- **Mixed Solvent Systems:** Employing a mixture of water and a miscible organic solvent such as THF, dioxane, or acetone can improve the solubility of both the amino acid and Boc₂O, facilitating a smoother reaction.[1]

Q4: My reaction is producing multiple products, including a di-Boc species. How can I improve selectivity?

The formation of multiple products typically points to over-reaction or reaction with other functional groups.

- **N,N-di-Boc Formation:** Primary amines can sometimes react twice, especially with a large excess of Boc₂O or in the presence of a strong base.[1] To prevent this, use a stoichiometric amount of Boc₂O (e.g., 1.1 equivalents) and monitor the reaction closely by TLC or LC-MS. [1]
- **Reaction with Other Nucleophiles:** If your substrate contains other nucleophilic groups like hydroxyls (-OH) or thiols (-SH), they may also react with Boc₂O. To favor N-protection, running the reaction at a lower temperature (0 °C to room temperature) without a strong base is advisable.[1]

N-Boc Protection: Mechanism & Workflow

The protection proceeds via a straightforward nucleophilic acyl substitution mechanism. The amine attacks one of the carbonyl carbons of the Boc anhydride, leading to the formation of a tetrahedral intermediate which then collapses to yield the N-Boc protected amine, tert-butanol, and carbon dioxide.

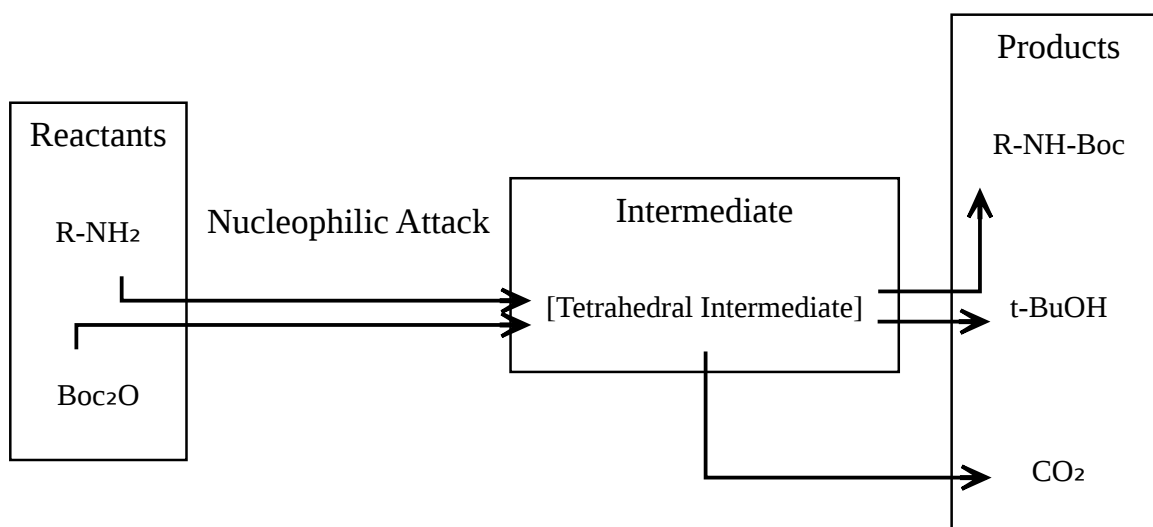

[Click to download full resolution via product page](#)

Caption: Mechanism of N-Boc Protection.

Standard Protocol for N-Boc Protection of a Primary Amine

- **Dissolution:** Dissolve the amine (1.0 eq) in a suitable solvent (e.g., Dichloromethane (DCM), THF, or a 1:1 mixture of Dioxane/Water).
- **Base Addition:** Add a base, such as triethylamine (TEA, 1.5 eq) or sodium bicarbonate (NaHCO₃, 3.0 eq if using aqueous media). Stir for 10-15 minutes.
- **Boc₂O Addition:** Add di-tert-butyl dicarbonate (Boc₂O, 1.1-1.2 eq) to the mixture.
- **Reaction:** Stir the reaction at room temperature. Monitor progress by TLC or LC-MS. Reactions are typically complete within 1-12 hours.^[1]
- **Work-up:**
 - Concentrate the reaction mixture under reduced pressure.
 - Dissolve the residue in an organic solvent like ethyl acetate.

- Wash the organic layer sequentially with a weak acid (e.g., 1M HCl or saturated NH₄Cl), water, and brine.[1]
- Dry the organic layer over anhydrous sodium sulfate (Na₂SO₄), filter, and concentrate in vacuo.
- Purification: Purify the crude product by flash column chromatography if necessary.

Part 2: Troubleshooting N-Boc Deprotection

The removal of the Boc group is most commonly achieved under acidic conditions. However, this step can be fraught with complications, including incomplete reactions and the formation of unwanted side products.

Frequently Asked Questions (FAQs): N-Boc Deprotection

Q1: My Boc deprotection is incomplete. What should I check first?

Incomplete deprotection is a common issue and can often be resolved by assessing the following:

- Acid Strength and Concentration: The most frequent cause is insufficient acid strength or concentration.[2] Trifluoroacetic acid (TFA) is a common choice, typically used in concentrations of 20-50% in a solvent like DCM.[7][8] For more resistant substrates, neat TFA or a stronger acid system like 4M HCl in dioxane may be necessary.[9][10]
- Reaction Time and Temperature: Some deprotections may require longer reaction times or gentle warming.[2][9] Monitor the reaction by TLC to determine the optimal time.
- Steric Hindrance: Substrates with significant steric bulk around the Boc-protected amine may require more forcing conditions for complete removal.[2][7]
- Problematic Residues: Certain amino acid derivatives, such as Boc-His(pi-Bom), are known to be more resistant to deprotection under standard conditions.[7][11]

Q2: I'm observing unexpected peaks in my LC-MS after deprotection. What are these side products and how can I prevent them?

The primary cause of side product formation is the generation of a reactive tert-butyl cation during the cleavage of the Boc group.^{[5][12][13]} This electrophile can alkylate nucleophilic residues in your molecule.^{[12][14]}

- **Susceptible Residues:** Amino acids with nucleophilic side chains are particularly vulnerable. These include Tryptophan (Trp), Methionine (Met), Cysteine (Cys), and Tyrosine (Tyr).^{[10][12][15]}
- **Prevention with Scavengers:** To prevent these side reactions, scavengers are added to the deprotection mixture to "trap" the tert-butyl cation.^{[2][12]} Common scavengers include triisopropylsilane (TIS), triethylsilane (TES), water, and thioanisole.^{[2][10]}

Q3: My compound contains other acid-sensitive functional groups. How can I selectively deprotect the N-Boc group?

When dealing with substrates containing other acid-labile groups (e.g., t-butyl esters, acetals), standard strong acid conditions are not suitable.^[9] Milder, alternative methods are required:

- **Lewis Acids:** Reagents like zinc bromide ($ZnBr_2$) can facilitate Boc deprotection under milder conditions.^{[10][16]}
- **In Situ HCl Generation:** A system of oxalyl chloride in methanol generates HCl in situ and has been reported as a mild and efficient method for deprotecting a wide range of N-Boc protected amines.^{[9][16][17][18]}
- **Thermal Deprotection:** In some cases, heating the N-Boc compound in a suitable solvent (e.g., refluxing in water or dioxane) can effect deprotection without any acid.^{[10][19][20]}

Q4: How should I properly work-up a TFA-mediated deprotection reaction?

Residual TFA can be difficult to remove and can complicate subsequent steps.

- **Co-evaporation:** After removing the bulk of the solvent and TFA under reduced pressure, add a high-boiling point, non-polar solvent like toluene and re-concentrate. Repeating this

process 2-3 times can help azeotropically remove residual TFA.[9]

- Precipitation: If the deprotected amine salt is a solid, it can often be precipitated by the addition of a non-polar solvent like cold diethyl ether.[7]
- Basic Work-up: If the free amine is desired and is not water-soluble, the residue can be dissolved in an organic solvent and washed with a basic aqueous solution (e.g., saturated NaHCO_3) to neutralize the TFA salt.[21]

N-Boc Deprotection: Mechanism & Troubleshooting Workflow

The acid-catalyzed deprotection proceeds via protonation of the carbonyl oxygen, followed by fragmentation to release the free amine (as its conjugate acid), carbon dioxide, and a stable tert-butyl cation.[5][8][13]

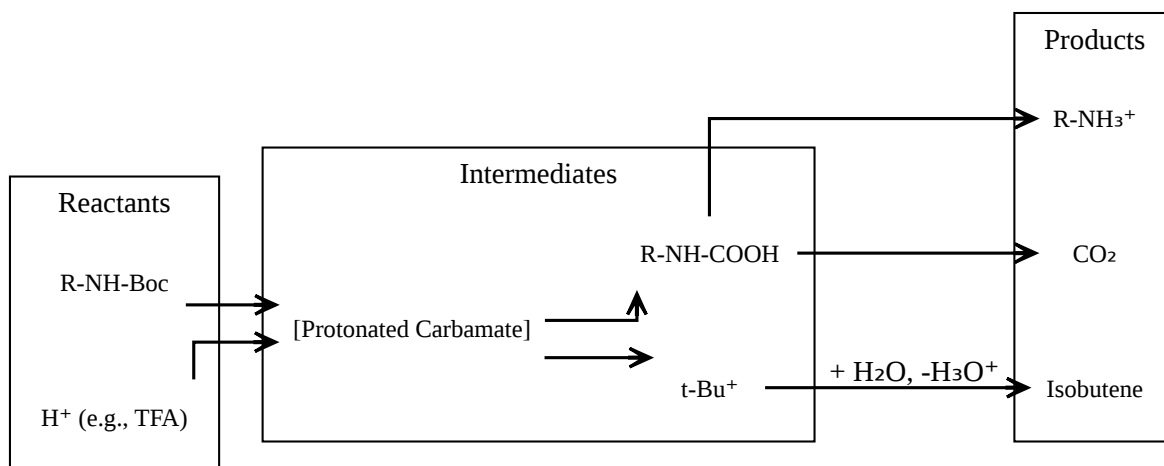

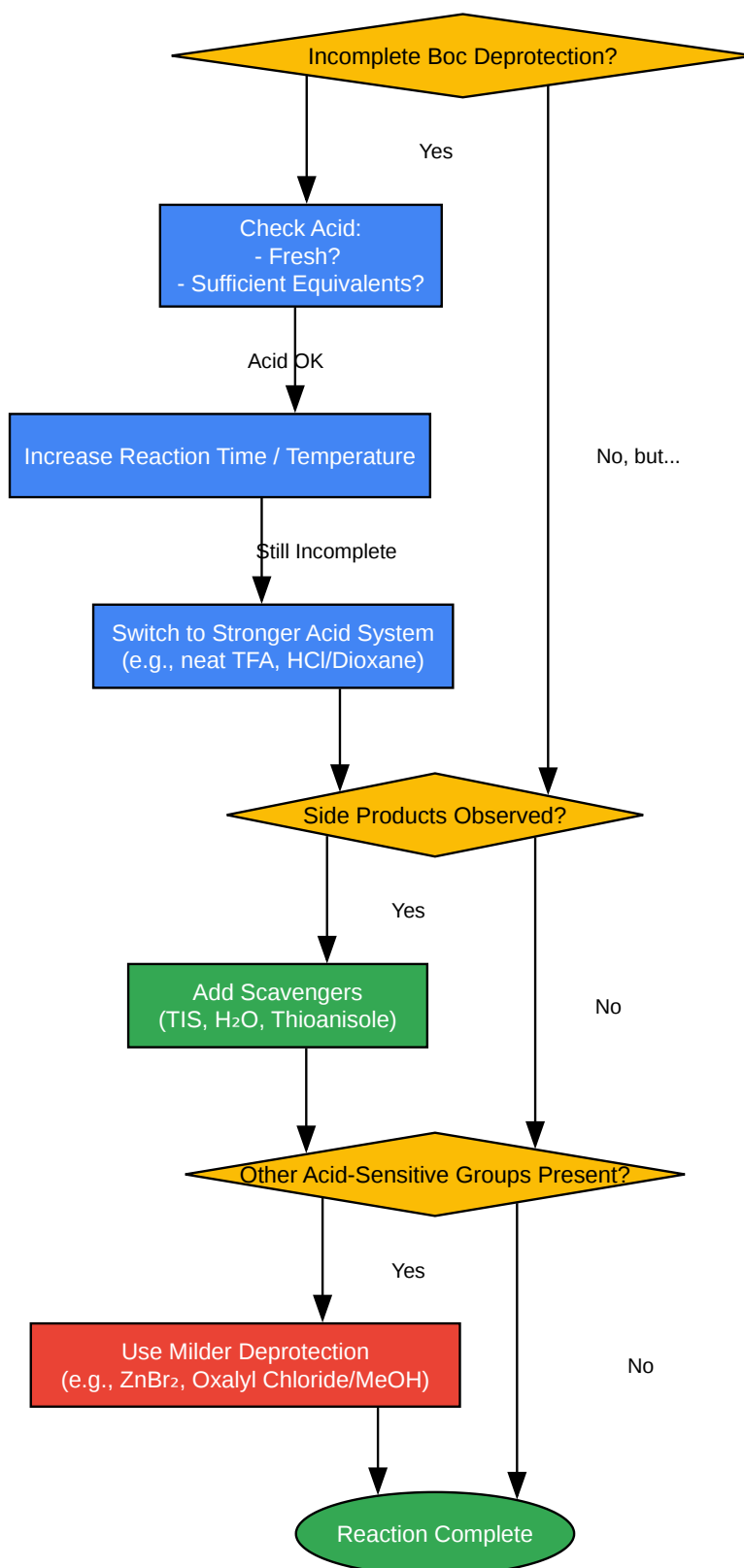

[Click to download full resolution via product page](#)

Caption: Troubleshooting Workflow for N-Boc Deprotection.

Comparative Data for N-Boc Deprotection

Table 1: Comparison of Common N-Boc Deprotection Reagents

Reagent/System	Typical Conditions	Advantages	Disadvantages
TFA/DCM	20-50% TFA in DCM, 0°C to RT, 1-2h [9]	Fast, efficient, volatile reagents are easy to remove.	Harsh; can cleave other acid-sensitive groups; generates reactive t-Bu ⁺ . [8][14]
HCl in Dioxane	4M HCl in 1,4-Dioxane, RT, <30 min [9]	Very effective, fast; product often precipitates as HCl salt.	Harsh; Dioxane is a hazardous solvent. [14]
Aqueous H ₃ PO ₄	85% H ₃ PO ₄ in water, RT to 50°C	Milder than TFA/HCl; useful for some acid-sensitive substrates. [16]	Non-volatile acid requires careful work-up.
ZnBr ₂ in DCM	1.5-3 eq ZnBr ₂ , DCM, RT, can be slow	Mild Lewis acid conditions; selective for N-Boc over some other groups. [10][16]	Reaction times can be long; work-up involves removing zinc salts.
(COCl) ₂ /MeOH	3 eq (COCl) ₂ , MeOH, RT, 1-4h [9][18]	Very mild; tolerates acid-labile esters. [10][17]	Oxalyl chloride is toxic and moisture-sensitive.
Refluxing H ₂ O	Neat H ₂ O, reflux, <15 min [19]	Environmentally benign, catalyst-free.	High temperature may not be suitable for all substrates.

Table 2: Guide to Scavenger Selection for TFA Deprotection

Scavenger	Target Residue(s)	Typical Conc. (v/v)	Notes
Water (H ₂ O)	General	2.5 - 5%	Traps t-Bu ⁺ to form t-butanol. A common component of cleavage cocktails.
Triisopropylsilane (TIS)	Trp, Tyr, Met, Cys	2.5 - 5%	Highly effective carbocation scavenger; reduces sulfoxides. [10]
Triethylsilane (TES)	Trp, Tyr, Met, Cys	2.5 - 5%	Similar efficacy to TIS. [10]
Thioanisole	Met, general	2.5 - 5%	Protects methionine from alkylation. Avoid if Trp is present. [10]
1,2-Ethanedithiol (EDT)	Trp	2.5%	Effective for preventing side reactions with tryptophan. [10]

Standard Protocol for N-Boc Deprotection using TFA

- **Dissolution:** Dissolve the N-Boc protected compound (1.0 eq) in DCM (approx. 0.1-0.2 M).
- **Cooling:** Cool the solution to 0 °C in an ice bath.
- **Reagent Addition:** Add Trifluoroacetic acid (TFA) to the desired concentration (e.g., for a 1:1 TFA/DCM solution, add a volume of TFA equal to the volume of DCM). If using scavengers, they should be added to the mixture at this stage.
- **Reaction:** Stir the reaction at 0 °C for 30 minutes, then allow it to warm to room temperature. Monitor by TLC or LC-MS until the starting material is consumed (typically 1-3 hours). [9]5.
Work-up:
 - Concentrate the reaction mixture under reduced pressure.

- Co-evaporate with toluene (2-3 times) to remove residual TFA. [9] * The resulting TFA salt can be used directly, or the free amine can be obtained by a basic aqueous work-up or by precipitation with a non-polar solvent. [21]

References

- Benchchem. (n.d.). Technical Support Center: Troubleshooting Incomplete Boc Protection of Amines.
- Benchchem. (n.d.). Technical Support Center: Alternative Methods for N-Boc Deprotection.
- Benchchem. (2025, December). Troubleshooting incomplete Boc deprotection in peptide synthesis.
- Benchchem. (n.d.). Scavengers for Boc deprotection to prevent side reactions.
- Total Synthesis. (2024, January 2). Boc Protecting Group: N-Boc Protection & Deprotection Mechanism.
- Benchchem. (n.d.). Troubleshooting incomplete Boc deprotection.
- Benchchem. (n.d.). Protocol for N-Boc Deprotection Using Trifluoroacetic Acid (TFA).
- Common Organic Chemistry. (n.d.). Boc Deprotection Mechanism - TFA.
- Benchchem. (n.d.). Troubleshooting Incomplete Boc Deprotection: A Technical Support Guide.
- George, N., et al. (2020). Mild deprotection of the N-tert-butyloxycarbonyl (N-Boc) group using oxalyl chloride. PMC.
- George, N., et al. (2020). Mild deprotection of the N-tert-butyloxycarbonyl (N-Boc) group using oxalyl chloride. RSC Publishing.
- Sigma-Aldrich. (n.d.). Application Note – N-Boc protection.
- Wordpress. (n.d.). BOC Deprotection.
- Benchchem. (n.d.). Technical Support Center: Boc Deprotection with Trifluoroacetic Acid (TFA).
- Benchchem. (n.d.). optimizing Boc deprotection conditions to avoid side reactions.
- Organic Chemistry Portal. (n.d.). Boc-Protected Amino Groups.
- Sigma-Aldrich. (n.d.). Boc Resin Cleavage Protocol.
- Semantic Scholar. (2012, May 27). A Simple and Efficient Green Method for the Deprotection of N-Boc in Various Structurally Diverse Amines under Water-mediated Catalyst-free Conditions.
- Reddit. (2024, February 27). Advice on N-boc deprotection in the presence of acid sensitive groups : r/Chempros.
- ResearchGate. (2013, January 14). How to do work-up of a BOC deprotection reaction by TFA?

- Yoshizawa-Kumagaye, K., et al. (2005). Amino acid deletion products resulting from incomplete deprotection of the Boc group from Npi-benzyloxymethylhistidine residues during solid-phase peptide synthesis. PubMed.
- Reddit. (2021, June 17). Having great trouble with a Boc-protection reaction : r/chemhelp.

Need Custom Synthesis?

BenchChem offers custom synthesis for rare earth carbides and specific isotopic labeling.

Email: info@benchchem.com or [Request Quote Online](#).

Sources

- [1. pdf.benchchem.com](https://pdf.benchchem.com) [pdf.benchchem.com]
- [2. pdf.benchchem.com](https://pdf.benchchem.com) [pdf.benchchem.com]
- [3. sigmaaldrich.com](https://sigmaaldrich.com) [sigmaaldrich.com]
- [4. reddit.com](https://reddit.com) [reddit.com]
- [5. total-synthesis.com](https://total-synthesis.com) [total-synthesis.com]
- [6. Boc-Protected Amino Groups](https://organic-chemistry.org) [organic-chemistry.org]
- [7. pdf.benchchem.com](https://pdf.benchchem.com) [pdf.benchchem.com]
- [8. pdf.benchchem.com](https://pdf.benchchem.com) [pdf.benchchem.com]
- [9. pdf.benchchem.com](https://pdf.benchchem.com) [pdf.benchchem.com]
- [10. pdf.benchchem.com](https://pdf.benchchem.com) [pdf.benchchem.com]
- [11. Amino acid deletion products resulting from incomplete deprotection of the Boc group from Npi-benzyloxymethylhistidine residues during solid-phase peptide synthesis - PubMed](https://pubmed.ncbi.nlm.nih.gov) [pubmed.ncbi.nlm.nih.gov]
- [12. pdf.benchchem.com](https://pdf.benchchem.com) [pdf.benchchem.com]
- [13. Boc Deprotection Mechanism - TFA](https://commonorganicchemistry.com) [commonorganicchemistry.com]
- [14. BOC Deprotection - Wordpress](https://reagents.acsgcipr.org) [reagents.acsgcipr.org]
- [15. pdf.benchchem.com](https://pdf.benchchem.com) [pdf.benchchem.com]
- [16. pdf.benchchem.com](https://pdf.benchchem.com) [pdf.benchchem.com]
- [17. Mild deprotection of the N-tert-butyloxycarbonyl \(N-Boc\) group using oxalyl chloride - PMC](https://pmc.ncbi.nlm.nih.gov) [pmc.ncbi.nlm.nih.gov]

- [18. pubs.rsc.org](https://pubs.rsc.org) [pubs.rsc.org]
- [19. pdfs.semanticscholar.org](https://pdfs.semanticscholar.org) [pdfs.semanticscholar.org]
- [20. reddit.com](https://reddit.com) [reddit.com]
- [21. researchgate.net](https://researchgate.net) [researchgate.net]
- To cite this document: BenchChem. [Technical Support Center: N-Boc Protection & Deprotection]. BenchChem, [2026]. [Online PDF]. Available at: [<https://www.benchchem.com/product/b15335827/docs#technical-support-center-n-boc-protection-deprotection>]

Disclaimer & Data Validity:

The information provided in this document is for Research Use Only (RUO) and is strictly not intended for diagnostic or therapeutic procedures. While BenchChem strives to provide accurate protocols, we make no warranties, express or implied, regarding the fitness of this product for every specific experimental setup.

Technical Support: The protocols provided are for reference purposes. Unsure if this reagent suits your experiment?

Need Industrial/Bulk Grade? [Request Custom Synthesis Quote](#)

BenchChem

Our mission is to be the trusted global source of essential and advanced chemicals, empowering scientists and researchers to drive progress in science and industry.

Contact

Address: 3281 E Guasti Rd
Ontario, CA 91761, United States
Phone: (601) 213-4426
Email: info@benchchem.com

[Contact our Ph.D. Support Team for a compatibility check](#)

