

A Comparative Guide to the Mass Spectrometry Fragmentation Patterns of Iodinated Benzoisothiazoles

Author: BenchChem Technical Support Team. **Date:** April 2026

Compound of Interest

Compound Name: *7-Iodobenzo[d]isothiazol-3-amine*

Cat. No.: *B15329542*

[Get Quote](#)

This guide provides an in-depth analysis of the mass spectrometric behavior of iodinated benzoisothiazoles, a class of compounds of increasing interest in medicinal chemistry and materials science. As direct literature on the mass spectrometry of this specific compound family is sparse, this guide synthesizes data from analogous structures—including benzothiazoles and other halogenated aromatics—to provide a predictive framework for researchers. We will explore the fragmentation patterns under both high-energy Electron Ionization (EI) and softer Electrospray Ionization (ESI) techniques, offering insights into experimental design and data interpretation.

Introduction: The Significance of Iodinated Benzoisothiazoles and Mass Spectrometry

The benzoisothiazole scaffold is a privileged structure in drug discovery, forming the core of various biologically active agents. The introduction of an iodine atom can significantly modulate a molecule's pharmacokinetic and pharmacodynamic properties, making iodinated analogs valuable for developing novel therapeutics and molecular probes.

Mass spectrometry (MS) is an indispensable tool for the structural elucidation of these novel compounds.^[1] By ionizing a molecule and analyzing the mass-to-charge ratio (m/z) of the resulting parent ion and its fragments, we can deduce its elemental composition and structural features. Understanding the characteristic fragmentation pathways is crucial for unambiguous identification and differentiation of isomers.

Ionization Techniques: A Comparative Overview

The choice of ionization method profoundly impacts the resulting mass spectrum. For iodinated benzoisothiazoles, the two most relevant techniques are Electron Ionization (EI) and Electrospray Ionization (ESI).

- **Electron Ionization (EI):** This is a high-energy technique where the analyte is bombarded with 70 eV electrons in the gas phase. This process imparts significant internal energy, leading to extensive and reproducible fragmentation. The resulting "fingerprint" spectrum is highly valuable for structural elucidation and library matching.
- **Electrospray Ionization (ESI):** A soft ionization technique, ESI generates ions from a solution by creating a fine, charged spray. It typically produces protonated molecules $[M+H]^+$ or deprotonated molecules $[M-H]^-$ with minimal fragmentation in the source.^[2] To induce fragmentation, tandem mass spectrometry (MS/MS), often involving Collision-Induced Dissociation (CID), is required.^{[2][3]}

Electron Ionization (EI) Fragmentation: Decoding the High-Energy Pathway

Under EI conditions, the molecular ion of an iodinated benzoisothiazole is expected to be a radical cation ($M^{+\bullet}$), which is often unstable and undergoes a series of fragmentation reactions. Based on studies of related benzothiazoles and halogenated aromatics, we can predict the primary fragmentation pathways.^{[4][5]}

Key Predicted Fragmentation Pathways under EI:

- **Carbon-Iodine Bond Cleavage:** The C-I bond is the weakest bond in the molecule, making the loss of an iodine radical ($\bullet I$, 127 Da) a highly favorable initial fragmentation step. This will result in a prominent $[M-I]^+$ ion.

- **Thiazole Ring Fission:** Following the general fragmentation of the benzothiazole ring, we anticipate the loss of neutral molecules like hydrogen cyanide (HCN) or carbon monosulfide (CS).[5] This often occurs after the initial loss of the iodine atom.
- **Loss of HCS/CNS:** Cleavage of the thiazole ring can lead to the expulsion of a \bullet HCS or \bullet CNS radical, leading to characteristic fragment ions.
- **Retro-Diels-Alder (RDA) type reactions:** The heterocyclic ring may undergo RDA-type cleavage, leading to the fragmentation of the core structure.[6]

Table 1: Predicted Key Fragments for a Hypothetical 5-Iodo-1,2-benzisothiazole under EI-MS

m/z Value (Proposed)	Ion Structure/Formula	Fragmentation Pathway
263	[C7H4INS] ⁺⁺	Molecular Ion (M ⁺⁺)
136	[C7H4NS] ⁺	[M - I] ⁺
109	[C6H3S] ⁺	[M - I - HCN] ⁺
92	[C6H4N] ⁺	[M - I - CS] ⁺

Below is a diagram illustrating the predicted primary fragmentation cascade for an iodinated benzisothiazole under EI.

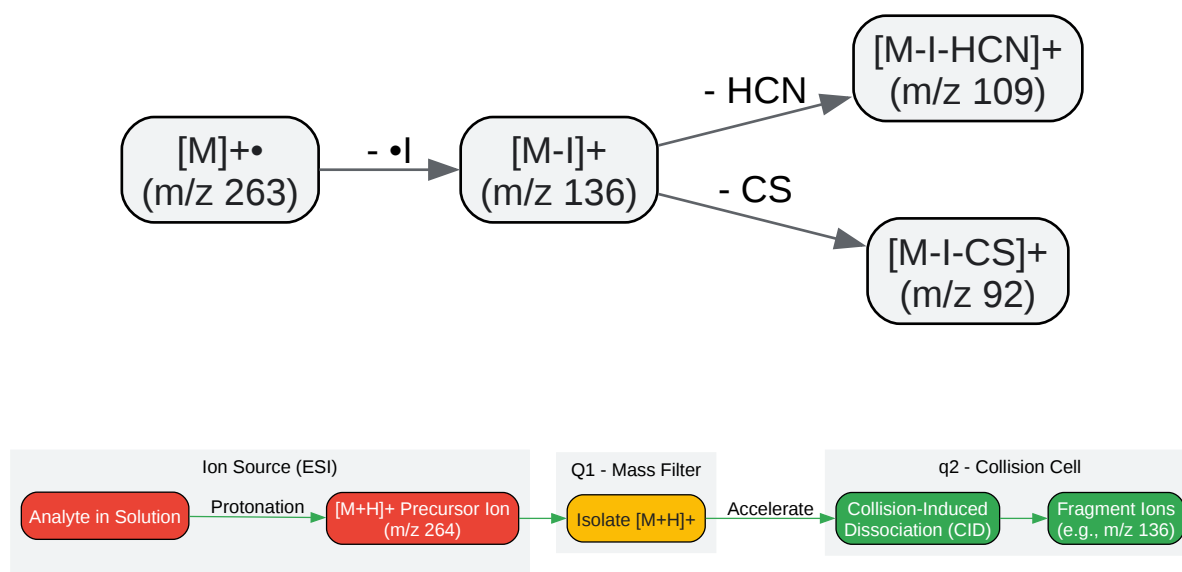

[Click to download full resolution via product page](#)

Caption: ESI-MS/MS workflow for fragmentation analysis.

Comparison with Other Halogenated Benzoisothiazoles

The fragmentation patterns of chloro- and bromo- analogs would be expected to show similar pathways, but with key differences in ion abundance. The C-X (X=Cl, Br, I) bond strength decreases down the group. Therefore, the loss of the halogen radical in EI-MS is most favorable for iodine, followed by bromine, and then chlorine. This would be reflected in the relative intensity of the $[M-X]^+$ peak compared to the molecular ion peak.

Alternative Analytical Techniques

While MS provides invaluable structural information, it should be used in conjunction with other techniques for complete characterization:

- Nuclear Magnetic Resonance (NMR) Spectroscopy: 1H and ^{13}C NMR are essential for determining the precise connectivity of atoms and the substitution pattern on the aromatic ring.
- X-Ray Crystallography: Provides unambiguous, three-dimensional structural information for crystalline compounds.

- Elemental Analysis: Confirms the elemental composition of the synthesized compound.

Experimental Protocols

Protocol 1: EI-MS Analysis via Gas Chromatography-Mass Spectrometry (GC-MS)

- Sample Preparation: Dissolve ~1 mg of the iodinated benzothiazole in 1 mL of a volatile solvent like dichloromethane or ethyl acetate.
- GC Separation:
 - Injector: 250 °C, Split mode (e.g., 50:1).
 - Column: Standard non-polar column (e.g., HP-5MS, 30 m x 0.25 mm x 0.25 μm).
 - Oven Program: Start at 100 °C, hold for 1 min, ramp to 280 °C at 15 °C/min, hold for 5 min.
 - Carrier Gas: Helium at a constant flow of 1 mL/min.
- MS Detection (EI):
 - Ion Source Temperature: 230 °C.
 - Quadrupole Temperature: 150 °C.
 - Electron Energy: 70 eV.
 - Scan Range: m/z 40-500.

Protocol 2: ESI-MS/MS Analysis via Liquid Chromatography-Mass Spectrometry (LC-MS)

- Sample Preparation: Prepare a 10 μg/mL solution of the analyte in a 50:50 mixture of acetonitrile and water.
- LC Separation:
 - Column: C18 reverse-phase column (e.g., 2.1 x 50 mm, 1.8 μm).

- Mobile Phase A: Water + 0.1% Acetic Acid (Note: Avoid formic acid to minimize in-source deiodination)[7][8].
- Mobile Phase B: Acetonitrile + 0.1% Acetic Acid.
- Gradient: Start at 5% B, ramp to 95% B over 5 minutes, hold for 2 minutes, then re-equilibrate.
- Flow Rate: 0.4 mL/min.
- MS/MS Detection (Positive ESI):
 - Capillary Voltage: 3.5 kV.
 - Source Temperature: 120 °C.
 - Desolvation Temperature: 350 °C.
 - Full Scan (MS1): Scan m/z 100-500 to find the [M+H]⁺ ion.
 - Product Ion Scan (MS2):
 - Set the quadrupole (Q1) to isolate the m/z of the [M+H]⁺ ion.
 - Apply collision energy (e.g., 15-30 eV, optimize for best fragmentation) in the collision cell with argon as the collision gas.
 - Scan the product ions in the final mass analyzer.

Conclusion

The mass spectrometric fragmentation of iodinated benzoisothiazoles is dictated by the interplay between the weak C-I bond and the inherent stability of the heterocyclic ring system. Under EI, the primary fragmentation is expected to be the loss of the iodine radical, followed by the characteristic cleavage of the thiazole ring. In ESI-MS/MS, the dominant pathway is the neutral loss of HI from the protonated molecule. Researchers must be particularly cautious of in-source deiodination when using ESI, especially with formic acid-containing mobile phases. By synthesizing knowledge from related chemical classes, this guide provides a robust

framework for the successful identification and characterization of this important family of molecules.

References

- Goksen, U. S., et al. (2021). Synthesis of novel benzothiazole derivatives and investigation of their enzyme inhibitory effects against Alzheimer's disease. *Bioorganic Chemistry*. Available at: [\[Link\]](#)
- Malik, A. et al. (2013). Deiodination of iodinated aromatic compounds with electrospray ionization mass spectrometry. *PubMed*. Available at: [\[Link\]](#)
- Malik, A. et al. (2013). Deiodination of iodinated aromatic compounds with electrospray ionization mass spectrometry. *ResearchGate*. Available at: [\[Link\]](#)
- Goksen, U. S., et al. (2021). Synthesis of novel benzothiazole derivatives and investigation of their enzyme inhibitory effects against Alzheimer's disease. *ResearchGate*. Available at: [\[Link\]](#)
- Papanov, S. et al. (2020). Substituted 3-Phenylpropenoates and Related Analogs: Electron Ionization Mass Spectral Fragmentation and Density Functional Theory Calculations. *PMC*. Available at: [\[Link\]](#)
- Wang, Y. et al. (2024). Synthesis and biological evaluation of novel benzothiazole derivatives as potential anticancer and antiinflammatory agents. *PMC*. Available at: [\[Link\]](#)
- Ingole, R.N. & Waghmare, S. A. Synthesis, Spectral Characterization and Biological Evaluation of Novel Substituted 2, 4-Dithiobiuretes with Benzothiazole Backb. *International Journal of Scientific & Engineering Research*. Available at: [\[Link\]](#)
- Al-Omran, F. & El-Khair, A. (2016). Synthesis, Spectroscopy and X-Ray Characterization, of Novel Derivatives of Substituted 2-(Benzothiazol-2'-ylthio)acetohydrazide. *SCIRP*. Available at: [\[Link\]](#)
- Takhistov, V. V., et al. (2024). Protocol for Structure Determination of Unknowns by EI Mass Spectrometry. III. Diagnostic Ions in Multiple Ring Carbo- and Heterocycles, and Mono-Functional Derivatives. *AIP Publishing*. Available at: [\[Link\]](#)

- eGyanKosh. (N/A). MASS SPECTROMETRY: FRAGMENTATION PATTERNS. eGyanKosh. Available at: [\[Link\]](#)
- Chemistry LibreTexts. (2023). Mass Spectrometry - Fragmentation Patterns. Chemistry LibreTexts. Available at: [\[Link\]](#)
- Nedopekin, D. A., et al. (2024). Mass spectra of new heterocycles: XXXI. Fragmentation of functionalized 2,3-dihydropyridines by electron ionization. ResearchGate. Available at: [\[Link\]](#)
- Prasain, J. (2010). Ion fragmentation of small molecules in mass spectrometry. University of Alabama at Birmingham. Available at: [\[Link\]](#)
- Broxton, T. J. (N/A). High resolution mass spectrometry.—II Some substituted benzothiazoles. Scite.ai. Available at: [\[Link\]](#)
- Vessecchi, R. et al. (2015). Fragmentation reactions using electrospray ionization mass spectrometry: an important tool for the structural elucidation and characterization of synthetic and natural products. RSC Publishing. Available at: [\[Link\]](#)
- International Atomic Energy Agency. (2025). Ionization and fragmentation of the six-membered heterocycles containing oxygen – Comparative studies of electron and photon impact on the 3,4-dihydro-2H-pyran molecules. IAEA. Available at: [\[Link\]](#)
- Xu, G., et al. (2020). Study of Free Radical Fragment Ions Generated from ESI-CID-MS-MS Using LTQ and LTQ Orbitrap Mass Spectrometers. LCGC International. Available at: [\[Link\]](#)
- Rocha, W. D., et al. (2006). Investigation of the ionisation and fragmentation behaviour of different nitroaromatic compounds occurring as polar metabolites of explosives using electrospray ionisation tandem mass spectrometry. PubMed. Available at: [\[Link\]](#)
- Zhang, X., et al. (2011). Fragmentation behaviors of triazolobenzodiazepines by electrospray ionization/quadrupole time-of-flight mass spectrometry. ResearchGate. Available at: [\[Link\]](#)
- Salem, M. A. I., et al. (2016). Mass Spectral Fragmentation Modes of Some New Pyrimidinethiones, Thiazolo[3,2-a]Pyrimidines and Bis -Pyrimidines. Scientific & Academic Publishing. Available at: [\[Link\]](#)

Need Custom Synthesis?

BenchChem offers custom synthesis for rare earth carbides and specific isotopic labeling.

Email: info@benchchem.com or [Request Quote Online](#).

Sources

- [1. chromatographyonline.com](https://www.chromatographyonline.com) [chromatographyonline.com]
- [2. Fragmentation reactions using electrospray ionization mass spectrometry: an important tool for the structural elucidation and characterization of synthetic and natural products - Natural Product Reports \(RSC Publishing\)](#) [pubs.rsc.org]
- [3. uab.edu](https://uab.edu) [uab.edu]
- [4. Substituted 3-Phenylpropenoates and Related Analogs: Electron Ionization Mass Spectral Fragmentation and Density Functional Theory Calculations - PMC](#) [pmc.ncbi.nlm.nih.gov]
- [5. scite.ai](https://scite.ai) [scite.ai]
- [6. pubs.aip.org](https://pubs.aip.org) [pubs.aip.org]
- [7. Deiodination of iodinated aromatic compounds with electrospray ionization mass spectrometry - PubMed](#) [pubmed.ncbi.nlm.nih.gov]
- [8. researchgate.net](https://researchgate.net) [researchgate.net]
- To cite this document: BenchChem. [A Comparative Guide to the Mass Spectrometry Fragmentation Patterns of Iodinated Benzoisothiazoles]. BenchChem, [2026]. [Online PDF]. Available at: [<https://www.benchchem.com/product/b15329542/docs#a-comparative-guide-to-the-mass-spectrometry-fragmentation-patterns-of-iodinated-benzoisothiazoles>]

Disclaimer & Data Validity:

The information provided in this document is for Research Use Only (RUO) and is strictly not intended for diagnostic or therapeutic procedures. While BenchChem strives to provide accurate protocols, we make no warranties, express or implied, regarding the fitness of this product for every specific experimental setup.

Technical Support: The protocols provided are for reference purposes. Unsure if this reagent suits your experiment?

Need Industrial/Bulk Grade? [Request Custom Synthesis Quote](#)

BenchChem

Our mission is to be the trusted global source of essential and advanced chemicals, empowering scientists and researchers to drive progress in science and industry.

Contact

Address: 3281 E Guasti Rd
Ontario, CA 91761, United States
Phone: (601) 213-4426
Email: info@benchchem.com

[Contact our Ph.D. Support Team for a compatibility check](#)