

Introduction: Elucidating the Molecular Fingerprint of a Novel Pyrazole Derivative

Author: BenchChem Technical Support Team. **Date:** May 2026

Compound of Interest

Compound Name: *3-Heptyl-4-methyl-1h-pyrazol-5-amine*

Cat. No.: *B15324025*

[Get Quote](#)

In the landscape of drug discovery and materials science, pyrazole derivatives stand out for their vast pharmacological and chemical potential.^{[1][2][3]} The compound **3-Heptyl-4-methyl-1H-pyrazol-5-amine** is a member of this versatile class, featuring a heterocyclic pyrazole core substituted with a long alkyl chain, a methyl group, and a primary amine. Understanding the precise molecular structure and intermolecular interactions of such compounds is paramount for predicting their activity, stability, and potential applications.

Fourier-Transform Infrared (FTIR) spectroscopy is an indispensable analytical technique that provides a unique "molecular fingerprint" by probing the vibrational modes of chemical bonds.^[4] This guide offers a comprehensive analysis of the expected FTIR characteristic peaks for **3-Heptyl-4-methyl-1H-pyrazol-5-amine**. As direct experimental data for this specific molecule is not widely published, this analysis is built upon a foundation of established spectroscopic principles and a comparative study of structurally analogous compounds. We will dissect the spectrum into contributions from its core functional groups—the primary amine, the substituted pyrazole ring, and the alkyl chains—to provide researchers with a robust framework for spectral interpretation and quality control.

Deconstructing the Spectrum: Predicted Vibrational Modes

The FTIR spectrum of **3-Heptyl-4-methyl-1H-pyrazol-5-amine** can be logically segmented into regions corresponding to its primary functional components. Each component possesses characteristic vibrational frequencies that serve as reliable identifiers.

The Primary Amine (-NH₂) Signature

The 5-amino group is a defining feature and provides some of the most distinct peaks in the spectrum.

- **N-H Stretching (3500-3250 cm⁻¹):** As a primary amine, the -NH₂ group will exhibit two distinct stretching vibrations: an asymmetric stretch at a higher wavenumber (typically 3400-3300 cm⁻¹) and a symmetric stretch at a lower wavenumber (3330-3250 cm⁻¹).^{[5][6]} The presence of two bands in this region is a hallmark of a primary amine.^[7] These peaks are generally sharper and less intense than the broad O-H stretching bands of alcohols.^[6]
- **N-H Bending/Scissoring (1650-1580 cm⁻¹):** This vibration arises from the scissoring motion of the two N-H bonds. It typically appears as a medium to strong, sharp band.^{[5][6]} Its position can sometimes overlap with C=C stretching vibrations from the pyrazole ring, but its intensity and shape are often characteristic.
- **N-H Wagging (910-665 cm⁻¹):** This out-of-plane bending vibration results in a broad and strong absorption band, providing another key indicator for primary and secondary amines.^{[5][7]}

The Pyrazole Heterocyclic Core

The pyrazole ring provides a complex but informative set of absorptions in the fingerprint region. Theoretical and experimental studies on pyrazole and its derivatives provide a basis for these assignments.^{[8][9]}

- **C=N and C=C Stretching (1610-1450 cm⁻¹):** The pyrazole ring contains both C=N and C=C bonds, and their stretching vibrations are coupled, resulting in a series of bands in this region. A notable C=N stretching band is often observed around 1610-1590 cm⁻¹.^{[10][11]}

- Ring Stretching and Deformation ($1550-1300\text{ cm}^{-1}$): The entire ring system undergoes stretching and breathing vibrations, leading to multiple absorptions in this part of the spectrum. These are highly specific to the substitution pattern on the ring.
- N-H In-Plane Bending (around $1200-1100\text{ cm}^{-1}$): The N-H bond of the pyrazole ring itself (the "1H" proton) will have an in-plane bending vibration, though it may be of medium to weak intensity.

The Alkyl Substituents (Heptyl and Methyl)

The heptyl and methyl groups contribute characteristic aliphatic C-H vibrations.

- C-H Asymmetric and Symmetric Stretching ($3000-2850\text{ cm}^{-1}$): These are typically strong, sharp peaks just below 3000 cm^{-1} . You can expect to see distinct absorptions for the $-\text{CH}_3$ group (asymmetric $\sim 2962\text{ cm}^{-1}$, symmetric $\sim 2872\text{ cm}^{-1}$) and the $-\text{CH}_2-$ groups of the heptyl chain (asymmetric $\sim 2926\text{ cm}^{-1}$, symmetric $\sim 2853\text{ cm}^{-1}$).
- C-H Bending/Deformation ($1470-1370\text{ cm}^{-1}$): The scissoring vibration of $-\text{CH}_2-$ groups appears around 1465 cm^{-1} , while the symmetric bending ("umbrella" mode) of the $-\text{CH}_3$ group is found near 1375 cm^{-1} .^[3]

Comparative Analysis: Insights from Analogous Structures

To validate our predicted peak assignments, we can compare them with experimental data from similar molecules.

- Comparison with 5-Aminopyrazoles: A study on the synthesis of 5-amino-1H-pyrazole-4-carbonitriles reports several relevant FTIR peaks. For instance, one derivative shows multiple bands for N-H stretching between 3485 and 3179 cm^{-1} and a strong $\text{C}=\text{N}/\text{C}=\text{C}$ absorption at 1643 cm^{-1} .^[12] This aligns well with our predictions for the amine and pyrazole core vibrations.
- Comparison with N-Substituted Pyrazolamines: The compound 3-(tert-Butyl)-N-(4-methoxybenzyl)-1-methyl-1H-pyrazol-5-amine, a secondary amine, shows a single N-H stretch at 3243 cm^{-1} and a $\text{C}=\text{N}$ pyrazole stretch at 1611 cm^{-1} .^[10] This highlights the key

difference between a primary amine (two N-H stretches) and a secondary amine (one N-H stretch) in this class of compounds.

- Comparison with 1-Phenyl-3-methyl-1H-pyrazol-5-amine: The NIST gas-phase IR spectrum for this close analog reveals key features.^[13] While peak positions shift in the gas phase, the spectrum clearly shows a pair of peaks in the N-H stretching region ($\sim 3500\text{-}3400\text{ cm}^{-1}$) and a strong absorption band around 1620 cm^{-1} , corroborating the expected primary amine and pyrazole C=N/C=C vibrations.

This comparative approach strengthens the confidence in our assignments for **3-Heptyl-4-methyl-1H-pyrazol-5-amine**. The presence of the long heptyl chain is expected to primarily increase the intensity of the C-H stretching and bending bands relative to analogs with smaller alkyl groups.

Summary of Predicted Characteristic FTIR Peaks

The following table summarizes the expected key vibrational frequencies and their assignments for **3-Heptyl-4-methyl-1H-pyrazol-5-amine**.

Wavenumber Range (cm ⁻¹)	Intensity	Vibrational Mode Assignment	Functional Group
3400 - 3300	Medium, Sharp	Asymmetric N-H Stretch	Primary Amine (-NH ₂)
3330 - 3250	Medium, Sharp	Symmetric N-H Stretch	Primary Amine (-NH ₂)
~3100	Medium-Weak	N-H Stretch	Pyrazole Ring (N-H)
2965 - 2950	Strong, Sharp	Asymmetric C-H Stretch	Methyl (-CH ₃)
2940 - 2915	Strong, Sharp	Asymmetric C-H Stretch	Methylene (-CH ₂)
2875 - 2865	Medium, Sharp	Symmetric C-H Stretch	Methyl (-CH ₃)
2860 - 2845	Medium, Sharp	Symmetric C-H Stretch	Methylene (-CH ₂)
1650 - 1580	Medium-Strong	N-H Bending (Scissoring)	Primary Amine (-NH ₂)
1610 - 1580	Medium-Strong	C=N Stretch	Pyrazole Ring
1580 - 1450	Medium-Weak	C=C Stretch & Ring Vibrations	Pyrazole Ring
~1465	Medium	C-H Bending (Scissoring)	Methylene (-CH ₂)
~1375	Medium-Weak	C-H Bending (Umbrella)	Methyl (-CH ₃)
1250 - 1020	Medium	C-N Stretch	Aryl Amine
910 - 665	Strong, Broad	N-H Wagging	Primary Amine (-NH ₂)

Visualizing the Molecular Structure and Vibrational Modes

The following diagram illustrates the structure of **3-Heptyl-4-methyl-1H-pyrazol-5-amine** with key bonds highlighted.

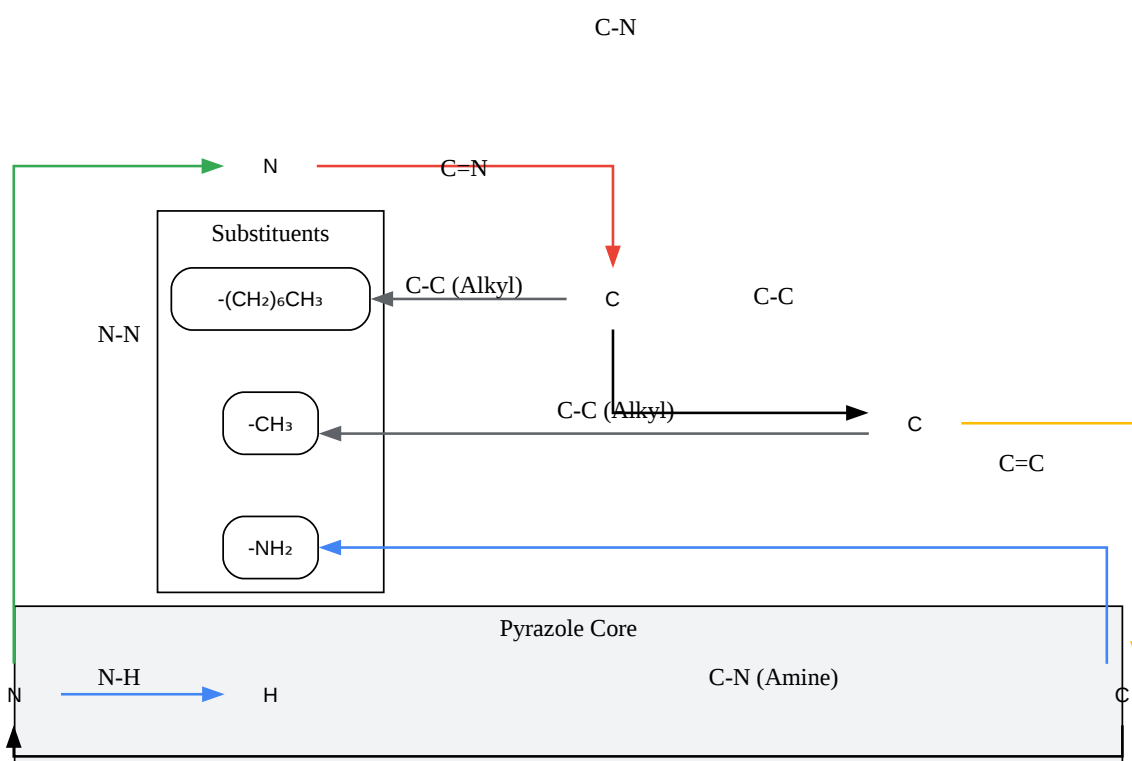

[Click to download full resolution via product page](#)

Caption: Key bonds in **3-Heptyl-4-methyl-1H-pyrazol-5-amine** responsible for characteristic FTIR peaks.

Experimental Protocol: Acquiring a High-Quality FTIR Spectrum

This section provides a standardized protocol for obtaining the FTIR spectrum of a solid sample like **3-Heptyl-4-methyl-1H-pyrazol-5-amine** using the Attenuated Total Reflectance (ATR) technique, which is ideal for its minimal sample preparation requirements.

Methodology: ATR-FTIR

- Instrument Preparation:
 - Ensure the FTIR spectrometer is powered on and has been allowed to stabilize for at least 30 minutes.
 - Verify that the ATR accessory (typically with a diamond or germanium crystal) is clean. Clean the crystal surface with a solvent-grade isopropanol or ethanol using a lint-free wipe and allow it to fully evaporate.
- Background Spectrum Collection:
 - With the clean, empty ATR crystal in place, collect a background spectrum. This is a critical self-validating step that measures the ambient atmosphere (CO₂, H₂O) and the instrument's response, which will be subtracted from the sample spectrum.
 - Typically, 16 to 32 scans are co-added at a resolution of 4 cm⁻¹ for a good signal-to-noise ratio.
- Sample Application:
 - Place a small amount of the solid **3-Heptyl-4-methyl-1H-pyrazol-5-amine** powder onto the center of the ATR crystal. Only enough sample to cover the crystal surface is needed.
 - Lower the ATR press arm and apply consistent pressure to ensure intimate contact between the sample and the crystal. Insufficient contact is a common source of poor-quality spectra.
- Sample Spectrum Collection:

- Collect the sample spectrum using the same parameters (number of scans, resolution) as the background scan.
- Data Processing and Analysis:
 - The instrument software will automatically ratio the sample spectrum against the background spectrum to produce the final absorbance spectrum.
 - Perform an ATR correction if necessary. This software function corrects for the wavelength-dependent depth of penetration of the evanescent wave, making the spectrum appear more like a traditional transmission spectrum.
 - Use the peak-picking tool to identify the wavenumbers of the key absorption bands.
 - Compare the obtained peak positions with the predicted values and data from analogous compounds to confirm the identity and purity of the sample.

Workflow Diagram: From Sample to Spectrum

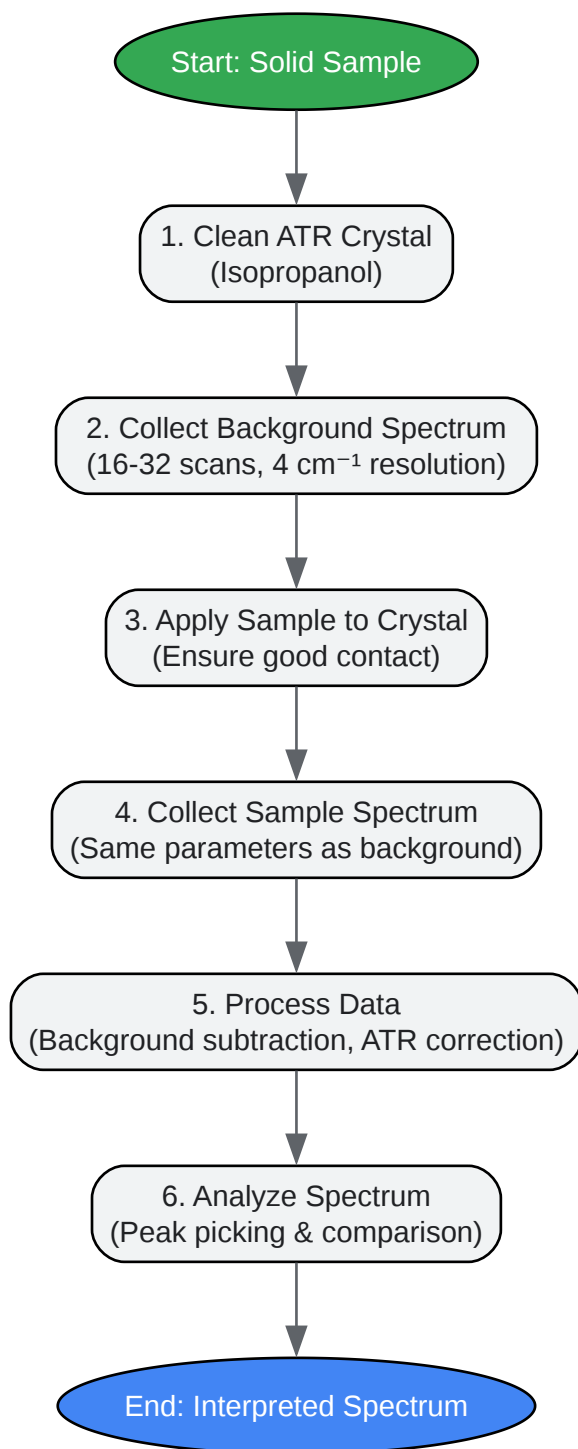

[Click to download full resolution via product page](#)

Need Custom Synthesis?

BenchChem offers custom synthesis for rare earth carbides and specific isotopic labeling.

Email: info@benchchem.com or [Request Quote Online](#).

Sources

- [1. connectjournals.com](https://connectjournals.com) [connectjournals.com]
- [2. researchgate.net](https://researchgate.net) [researchgate.net]
- [3. derpharmachemica.com](https://derpharmachemica.com) [derpharmachemica.com]
- [4. azooptics.com](https://azooptics.com) [azooptics.com]
- [5. orgchemboulder.com](https://orgchemboulder.com) [orgchemboulder.com]
- [6. wikieducator.org](https://wikieducator.org) [wikieducator.org]
- [7. spectroscopyonline.com](https://spectroscopyonline.com) [spectroscopyonline.com]
- [8. acrhem.org](https://acrhem.org) [acrhem.org]
- [9. Molecular structure, vibrational spectral studies of pyrazole and 3,5-dimethyl pyrazole based on density functional calculations - PubMed](https://pubmed.ncbi.nlm.nih.gov) [pubmed.ncbi.nlm.nih.gov]
- [10. mdpi.com](https://mdpi.com) [mdpi.com]
- [11. Synthesis of 4,4'-\(arylmethylene\)bis\(3-methyl-1-phenyl-1H-pyrazol-5-ols\) and evaluation of their antioxidant and anticancer activities - PMC](https://pmc.ncbi.nlm.nih.gov) [pmc.ncbi.nlm.nih.gov]
- [12. rsc.org](https://rsc.org) [rsc.org]
- [13. 1H-Pyrazol-5-amine, 3-methyl-1-phenyl-](https://webbook.nist.gov) [webbook.nist.gov]
- To cite this document: BenchChem. [Introduction: Elucidating the Molecular Fingerprint of a Novel Pyrazole Derivative]. BenchChem, [2026]. [Online PDF]. Available at: [<https://www.benchchem.com/product/b15324025/docs#introduction-elucidating-the-molecular-fingerprint-of-a-novel-pyrazole-derivative>]

Disclaimer & Data Validity:

The information provided in this document is for Research Use Only (RUO) and is strictly not intended for diagnostic or therapeutic procedures. While BenchChem strives to provide accurate protocols, we make no warranties, express or implied, regarding the fitness of this product for every specific experimental setup.

Technical Support: The protocols provided are for reference purposes. Unsure if this reagent suits your experiment?

Need Industrial/Bulk Grade? [Request Custom Synthesis Quote](#)

BenchChem

Our mission is to be the trusted global source of essential and advanced chemicals, empowering scientists and researchers to drive progress in science and industry.

Contact

Address: 3281 E Guasti Rd

Ontario, CA 91761, United States

Phone: (601) 213-4426

Email: info@benchchem.com

[Contact our Ph.D. Support Team for a compatibility check](#)