

# Application Notes and Protocols for the Regioselective Synthesis of Substituted Pyrazoles

**Author:** BenchChem Technical Support Team. **Date:** May 2026

## Compound of Interest

Compound Name:	4-Chloro-5-phenyl-3-(trifluoromethyl)pyrazole
CAS No.:	235106-13-5
Cat. No.:	B1582569

[Get Quote](#)

For: Researchers, scientists, and drug development professionals.

## Introduction: The Strategic Importance of Pyrazoles

Pyrazoles, five-membered aromatic heterocycles with two adjacent nitrogen atoms, represent a cornerstone of modern medicinal chemistry. Their versatile structure serves as a "privileged scaffold," appearing in a wide array of blockbuster drugs, including the anti-inflammatory agent Celebrex®, the erectile dysfunction treatment Viagra®, and the cannabinoid receptor antagonist Rimonabant.[1][2][3] The biological activity of pyrazole derivatives is profoundly influenced by the nature and position of substituents on the ring.[4][5] Consequently, the ability to control the regioselectivity of their synthesis—that is, to dictate the precise placement of functional groups—is of paramount importance for the efficient discovery and development of new therapeutic agents.[6][7]

These application notes provide a detailed guide to the most reliable and field-proven techniques for achieving regioselective control in pyrazole synthesis. We will move beyond

simple procedural lists to explore the underlying mechanistic principles that govern selectivity, offering insights that empower researchers to troubleshoot and adapt these methods for their specific molecular targets.

## Foundational Strategy: Cyclocondensation of 1,3-Dicarbonyl Compounds

The reaction of a 1,3-dicarbonyl compound with a hydrazine derivative is the most classic and widely employed method for pyrazole synthesis, often referred to as the Knorr pyrazole synthesis.[8][9] When an unsymmetrical 1,3-diketone and a monosubstituted hydrazine are used, the reaction can theoretically yield two different regioisomers.[10]

### Mechanism and Determinants of Regioselectivity

The reaction proceeds through the initial nucleophilic attack of one of the hydrazine nitrogens onto one of the carbonyl carbons. The regiochemical outcome is determined by which carbonyl group is attacked first and which nitrogen atom of the substituted hydrazine acts as the initial nucleophile. Key factors influencing this selectivity include:

- **Steric Hindrance:** The less sterically hindered carbonyl group is generally favored for the initial attack.
- **Electronic Effects:** Electron-withdrawing groups on the diketone can activate a carbonyl group towards nucleophilic attack. Conversely, the nucleophilicity of the hydrazine nitrogens is influenced by the electronic nature of its substituent.
- **Reaction Conditions (pH and Solvent):** The pH of the reaction medium can significantly alter the regioselectivity by protonating either the carbonyl oxygen or the hydrazine nitrogen, thereby modulating their reactivity.[10] The choice of solvent can also play a crucial role, with fluorinated alcohols like 1,1,1,3,3,3-hexafluoroisopropanol (HFIP) having been shown to dramatically improve regioselectivity in favor of the 5-arylpyrazole isomers.[11]

The general mechanism involves the formation of a hydrazone intermediate, followed by intramolecular cyclization and dehydration to afford the aromatic pyrazole ring.[12]

## Visualizing the Knorr Synthesis Pathway

The following diagram illustrates the competing pathways in the Knorr synthesis leading to two possible regioisomers.

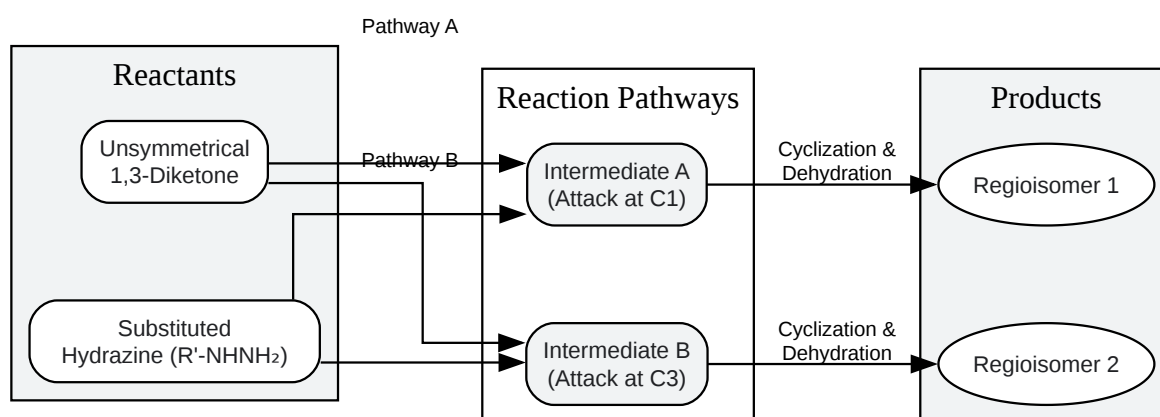

[Click to download full resolution via product page](#)

Caption: Competing pathways in the Knorr pyrazole synthesis.

## Protocol 1: Regioselective Knorr Synthesis of a 1,5-Disubstituted Pyrazole

This protocol details the synthesis of 1-phenyl-5-methyl-3-(trifluoromethyl)-1H-pyrazole, a common structural motif in agrochemicals and pharmaceuticals. The strong electron-withdrawing nature of the trifluoromethyl group directs the initial nucleophilic attack to the adjacent carbonyl.

Materials:

- 1,1,1-Trifluoro-2,4-pentanedione (1.0 mmol, 1 equiv.)
- Phenylhydrazine (1.0 mmol, 1 equiv.)
- Ethanol (5 mL)
- Glacial Acetic Acid (catalytic amount, ~2 drops)

#### Procedure:

- To a 25 mL round-bottom flask equipped with a magnetic stir bar and a reflux condenser, add 1,1,1-trifluoro-2,4-pentanedione and ethanol.
- Stir the solution at room temperature and add phenylhydrazine dropwise.
- Add the catalytic amount of glacial acetic acid to the mixture.
- Heat the reaction mixture to reflux (approximately 80°C) and monitor the reaction progress by Thin Layer Chromatography (TLC) using a 3:1 hexane/ethyl acetate eluent system.
- After completion (typically 2-4 hours), cool the reaction mixture to room temperature.
- Remove the solvent under reduced pressure using a rotary evaporator.
- Purify the crude product by flash column chromatography on silica gel, eluting with a gradient of hexane/ethyl acetate to afford the desired 1,5-disubstituted pyrazole as the major regioisomer.

Self-Validation: The regiochemical outcome can be confirmed by <sup>1</sup>H and <sup>13</sup>C NMR spectroscopy. The chemical shifts of the pyrazole ring protons and carbons are sensitive to the substituent pattern. For unambiguous assignment, 2D NMR techniques such as HMBC and NOESY can be employed.

## Advanced Strategy: [3+2] Dipolar Cycloaddition

A powerful and often highly regioselective alternative to cyclocondensation is the [3+2] dipolar cycloaddition reaction. This method involves the reaction of a 1,3-dipole with a dipolarophile. For pyrazole synthesis, nitrile imines are common 1,3-dipoles, which react with alkynes or alkenes.<sup>[13][14][15]</sup>

## Controlling Regioselectivity in Cycloadditions

The regioselectivity of these cycloadditions is primarily governed by the electronic properties of the reacting partners, as described by frontier molecular orbital (FMO) theory. The reaction proceeds through an interaction between the highest occupied molecular orbital (HOMO) of one component and the lowest unoccupied molecular orbital (LUMO) of the other. The

regiochemistry is determined by the orbital coefficients of the interacting atoms. Generally, the reaction favors the isomer where the atoms with the largest orbital coefficients on the HOMO and LUMO are bonded.

## Visualizing the [3+2] Cycloaddition Workflow

This diagram outlines the general workflow for synthesizing pyrazoles via a [3+2] cycloaddition of in situ generated nitrile imines.

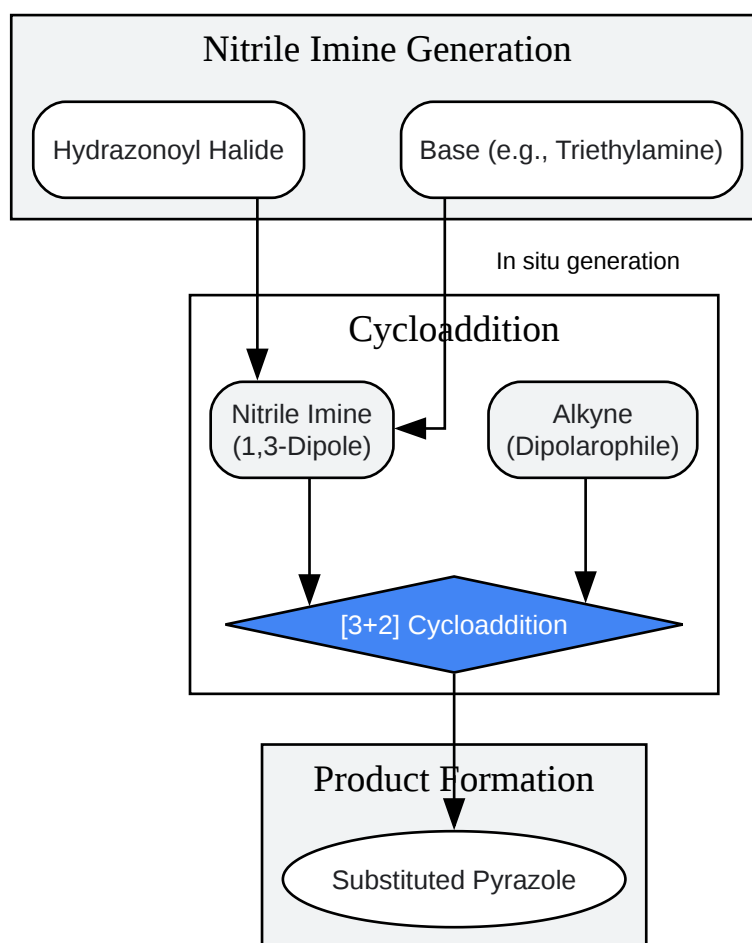

[Click to download full resolution via product page](#)

Caption: Workflow for [3+2] cycloaddition pyrazole synthesis.

## Protocol 2: Regioselective Synthesis of a 1,3,5-Trisubstituted Pyrazole via [3+2] Cycloaddition

This protocol describes a highly regioselective synthesis of a 1,3,5-trisubstituted pyrazole.[16]

#### Materials:

- N-phenyl-2-oxopropanehydrazonoyl chloride (1.0 mmol, 1 equiv.)
- Phenylacetylene (1.2 mmol, 1.2 equiv.)
- Triethylamine (1.5 mmol, 1.5 equiv.)
- Toluene (10 mL)

#### Procedure:

- In a flame-dried Schlenk flask under an inert atmosphere (nitrogen or argon), dissolve N-phenyl-2-oxopropanehydrazonoyl chloride and phenylacetylene in dry toluene.
- Add triethylamine to the solution via syringe.
- Heat the reaction mixture to 80°C and stir for 12-16 hours. Monitor the reaction by TLC.
- Upon completion, cool the reaction to room temperature.
- Filter the mixture to remove the triethylammonium chloride salt and wash the solid with a small amount of toluene.
- Combine the filtrate and washings, and concentrate under reduced pressure.
- Purify the residue by column chromatography (silica gel, hexane/ethyl acetate) to yield the pure 1,3,5-trisubstituted pyrazole.

**Self-Validation:** The regioselectivity of the cycloaddition is typically very high with terminal alkynes, leading to the 1,3,5-substitution pattern. Confirmation is achieved through NMR spectroscopy. The absence of signals corresponding to the other possible regioisomer (1,3,4-trisubstituted) in the <sup>1</sup>H NMR spectrum is a strong indicator of high regioselectivity.

## Emerging Technologies: Flow Chemistry for Enhanced Control

Continuous flow chemistry is emerging as a powerful tool for heterocycle synthesis, including pyrazoles.<sup>[17][18][19]</sup> Flow reactors offer precise control over reaction parameters such as temperature, pressure, and residence time, which can lead to improved yields, higher regioselectivity, and enhanced safety, particularly for reactions involving unstable intermediates.<sup>[13][20]</sup> For instance, the two-step synthesis of pyrazoles from acetophenones can be efficiently performed in a flow system, where an intermediate enaminone is generated and then condensed with hydrazine in a continuous manner.<sup>[17]</sup>

## Comparative Data of Synthetic Methodologies

Method	Key Reactants	Regioselectivity Control	Advantages	Limitations
Knorr Synthesis	1,3-Dicarbonyl, Hydrazine	Steric/electronic effects of substituents, pH, solvent[10][11]	Readily available starting materials, well-established.	Can produce mixtures of regioisomers, requiring separation.[8][21]
[3+2] Cycloaddition	Nitrile Imine, Alkyne/Alkenes	Frontier Molecular Orbitals (FMO) [14]	High regioselectivity, broad substrate scope.	Requires preparation of dipole precursors, may need inert conditions.
Synthesis from $\alpha,\beta$ -Unsaturated Carbonyls	Enones, Hydrazine	Controlled by the initial Michael addition step.	Access to pyrazoline intermediates, versatile.	Often requires a subsequent oxidation step to form the pyrazole.[8][14]
Flow Chemistry	Various (e.g., Acetophenones, Hydrazines)	Precise control of reaction parameters (temp., time).[17]	High throughput, improved safety and scalability, potential for higher selectivity. [18]	Requires specialized equipment.

## Conclusion and Future Outlook

The regioselective synthesis of substituted pyrazoles is a mature field, yet one that continues to evolve. While classic methods like the Knorr synthesis remain workhorses in the field, modern techniques such as metal-catalyzed cross-couplings and [3+2] cycloadditions offer superior levels of control for accessing complex substitution patterns.[2][22] The advent of enabling technologies like flow chemistry promises to further refine our ability to produce these vital heterocyclic compounds with even greater efficiency and precision. For the medicinal chemist and drug development professional, a thorough understanding of the principles governing

regioselectivity across these varied synthetic approaches is essential for the successful design and synthesis of next-generation pyrazole-based therapeutics.

## References

- GalChimia. (n.d.). Two-Stage Synthesis of Pyrazoles from Acetophenones by Flow Chemistry. GalChimia Technical Note. [\[Link\]](#)
- Bao, W., et al. (2012). Synthesis of Fully Substituted Pyrazoles via Regio- and Chemoselective Metalations. *Organic Letters*. [\[Link\]](#)
- Ferreira, R., et al. (2023). The Role of Flow Chemistry on the Synthesis of Pyrazoles, Pyrazolines and Pyrazole-Fused Scaffolds. *Molecules*. [\[Link\]](#)
- Ötvös, S. B., et al. (2019). Continuous-flow synthesis of 3,5-disubstituted pyrazoles via sequential alkyne homocoupling and Cope-type hydroamination. *RSC Advances*. [\[Link\]](#)
- Ferreira, R., et al. (2023). The Role of Flow Chemistry on the Synthesis of Pyrazoles, Pyrazolines and Pyrazole-Fused Scaffolds. *ResearchGate*. [\[Link\]](#)
- Burke, A., et al. (2023). Photochemical Synthesis of Pyrazolines from Tetrazoles in Flow. *SynOpen*. [\[Link\]](#)
- El-Malah, A. A., et al. (2023). Recent Advances in the Synthesis of Pyrazole Derivatives: A Review. *Reactions*. [\[Link\]](#)
- Naim, M. J., et al. (2016). Synthesis and Pharmacological Activities of Pyrazole Derivatives: A Review. *Molecules*. [\[Link\]](#)
- Padwa, A., et al. (2001). A Novel One-Pot Method for the Preparation of Pyrazoles by 1,3-Dipolar Cycloadditions of Diazo Compounds Generated in Situ. *The Journal of Organic Chemistry*. [\[Link\]](#)
- Kumar, V., et al. (2016). Recent applications of pyrazole and its substituted analogs. *International Journal of Pharmaceutical Sciences and Research*. [\[Link\]](#)
- Dömling, A., et al. (2018). Multicomponent syntheses of pyrazoles via (3 + 2)-cyclocondensation and (3 + 2)-cycloaddition key steps. *Beilstein Journal of Organic*

Chemistry. [\[Link\]](#)

- Basile, A., et al. (2023). Amino-Pyrazoles in Medicinal Chemistry: A Review. *Molecules*. [\[Link\]](#)
- Dömling, A., et al. (2018). Multicomponent syntheses of pyrazoles via (3 + 2)-cyclocondensation and (3 + 2)-cycloaddition key steps. *Beilstein Journal of Organic Chemistry*. [\[Link\]](#)
- Tian, S., et al. (2019). Temperature-Controlled Divergent Synthesis of Pyrazoles and 1-Tosyl-1H-pyrazoles under Transition-Metal-Catalyst- and Oxidant-Free Conditions. *Molecules*. [\[Link\]](#)
- Anonymous. (n.d.). Green Synthesis of Pyrazole Derivatives employing 1,3-Dipolar Cycloaddition Reaction using Phenyl hydrazones and Benzoquinone. *International Journal of Trend in Scientific Research and Development*. [\[Link\]](#)
- Asif, M., et al. (2024). Diverse Pharmacological Potential of different Substituted Pyrazole Derivatives. *Current Organic Synthesis*. [\[Link\]](#)
- Organic Chemistry Portal. (n.d.). Pyrazole synthesis. *Organic Chemistry Portal*. [\[Link\]](#)
- Zhang, Z., et al. (2024). Recent advances in the multicomponent synthesis of pyrazoles. *Organic & Biomolecular Chemistry*. [\[Link\]](#)
- Mogahid, M., et al. (2020). Substituted Pyrazoles and Their Heteroannulated Analogs—Recent Syntheses and Biological Activities. *Molecules*. [\[Link\]](#)
- Wang, X., et al. (2018). Synthesis of 1,3,5-trisubstituted pyrazoles via 1,3-dipolar cycloaddition of nitrile imines with ninhydrin-derived Morita–Baylis–Hillman carbonates. *Organic & Biomolecular Chemistry*. [\[Link\]](#)
- Kumar, R., & Sharma, R. (2018). Pyrazole and its Derivatives: An Excellent N-Hetrocycle with Wide Range of Biological Applications. *International Journal of Advances in Scientific Research*. [\[Link\]](#)
- Katritzky, A. R., et al. (2001). Regioselective Synthesis of Polysubstituted Pyrazoles and Isoxazoles. *The Journal of Organic Chemistry*. [\[Link\]](#)

- Synfacts. (2020). Regioselective Synthesis of 3,5-Disubstituted Pyrazoles. Thieme Chemistry. [\[Link\]](#)
- Skrydstrup, T., et al. (2022). Discovery of unexpectedly complex reaction pathways for the Knorr pyrazole synthesis via transient flow. Reaction Chemistry & Engineering. [\[Link\]](#)
- de la Cruz, P., et al. (2009). Improved Regioselectivity in Pyrazole Formation through the Use of Fluorinated Alcohols as Solvents: Synthesis and Biological Activity of New 5-Aryl-1-methyl-3-(trifluoromethyl)pyrazoles. Journal of Organic Chemistry. [\[Link\]](#)
- Elguero, J., et al. (1998). The reaction between hydrazines and  $\beta$ -dicarbonyl compounds: Proposal for a mechanism. Canadian Journal of Chemistry. [\[Link\]](#)
- Wikipedia. (n.d.). Paal–Knorr synthesis. Wikipedia. [\[Link\]](#)
- Li, T., et al. (2024). Regioselective Pyrazole Synthesis via Base-Mediated [3+2] Cycloaddition of 2-Alkynyl-1,3-Dithianes and Sydnone. The Journal of Organic Chemistry. [\[Link\]](#)
- de la Hoz, A., et al. (2000). Microwave-Assisted Paal-Knorr Reaction – Three-Step Regiocontrolled Synthesis of Polysubstituted Furans, Pyrroles and Thiophenes. Synlett. [\[Link\]](#)
- Organic Chemistry Portal. (n.d.). Paal-Knorr Pyrrole Synthesis. Organic Chemistry Portal. [\[Link\]](#)
- Kamal, A., et al. (2007). Paal–Knorr pyrrole synthesis. Tetrahedron. [\[Link\]](#)

### Need Custom Synthesis?

BenchChem offers custom synthesis for rare earth carbides and specific isotopic labeling.

Email: [info@benchchem.com](mailto:info@benchchem.com) or [Request Quote Online](#).

## Sources

- 1. [allresearchjournal.com](http://allresearchjournal.com) [[allresearchjournal.com](http://allresearchjournal.com)]

- [2. Multicomponent syntheses of pyrazoles via \(3 + 2\)-cyclocondensation and \(3 + 2\)-cycloaddition key steps - PMC \[pmc.ncbi.nlm.nih.gov\]](#)
- [3. Pyrazole and its Derivatives: An Excellent N-Hetrocycle with Wide Range of Biological Applications – Oriental Journal of Chemistry \[orientjchem.org\]](#)
- [4. Diverse Pharmacological Potential of different Substituted Pyrazole Derivatives | Bentham Science \[benthamscience.com\]](#)
- [5. Substituted Pyrazoles and Their Heteroannulated Analogs—Recent Syntheses and Biological Activities - PMC \[pmc.ncbi.nlm.nih.gov\]](#)
- [6. Temperature-Controlled Divergent Synthesis of Pyrazoles and 1-Tosyl-1H-pyrazoles under Transition-Metal-Catalyst- and Oxidant-Free Conditions - PMC \[pmc.ncbi.nlm.nih.gov\]](#)
- [7. Regioselective Synthesis of 3,5-Disubstituted Pyrazoles - Thieme Chemistry - Georg Thieme Verlag KG \[thieme.de\]](#)
- [8. Recent Advances in the Synthesis of Pyrazole Derivatives: A Review \[mdpi.com\]](#)
- [9. Paal–Knorr synthesis - Wikipedia \[en.wikipedia.org\]](#)
- [10. Discovery of unexpectedly complex reaction pathways for the Knorr pyrazole synthesis via transient flow - Reaction Chemistry & Engineering \(RSC Publishing\) DOI:10.1039/D2RE00271J \[pubs.rsc.org\]](#)
- [11. ri.conicet.gov.ar \[ri.conicet.gov.ar\]](#)
- [12. researchgate.net \[researchgate.net\]](#)
- [13. researchgate.net \[researchgate.net\]](#)
- [14. Synthesis and Pharmacological Activities of Pyrazole Derivatives: A Review - PMC \[pmc.ncbi.nlm.nih.gov\]](#)
- [15. pubs.acs.org \[pubs.acs.org\]](#)
- [16. Synthesis of 1,3,5-trisubstituted pyrazoles via 1,3-dipolar cycloaddition of nitrile imines with ninhydrin-derived Morita–Baylis–Hillman carbonates - Organic & Biomolecular Chemistry \(RSC Publishing\) \[pubs.rsc.org\]](#)
- [17. galchimia.com \[galchimia.com\]](#)
- [18. mdpi.com \[mdpi.com\]](#)
- [19. Continuous-flow synthesis of 3,5-disubstituted pyrazoles via sequential alkyne homocoupling and Cope-type hydroamination - RSC Advances \(RSC Publishing\) \[pubs.rsc.org\]](#)
- [20. Thieme E-Journals - SynOpen / Abstract \[thieme-connect.com\]](#)

- 21. BJOC - Multicomponent syntheses of pyrazoles via (3 + 2)-cyclocondensation and (3 + 2)-cycloaddition key steps [[beilstein-journals.org](https://beilstein-journals.org)]
- 22. [pubs.acs.org](https://pubs.acs.org) [[pubs.acs.org](https://pubs.acs.org)]
- To cite this document: BenchChem. [Application Notes and Protocols for the Regioselective Synthesis of Substituted Pyrazoles]. BenchChem, [2026]. [Online PDF]. Available at: [<https://www.benchchem.com/product/b1582569/docs#application-notes-and-protocols-for-the-regioselective-synthesis-of-substituted-pyrazoles>]

### Disclaimer & Data Validity:

The information provided in this document is for Research Use Only (RUO) and is strictly not intended for diagnostic or therapeutic procedures. While BenchChem strives to provide accurate protocols, we make no warranties, express or implied, regarding the fitness of this product for every specific experimental setup.

**Technical Support:** The protocols provided are for reference purposes. Unsure if this reagent suits your experiment?

**Need Industrial/Bulk Grade?** [Request Custom Synthesis Quote](#)

## BenchChem

Our mission is to be the trusted global source of essential and advanced chemicals, empowering scientists and researchers to drive progress in science and industry.

### Contact

Address: 3281 E Guasti Rd  
Ontario, CA 91761, United States  
Phone: (601) 213-4426  
Email: [info@benchchem.com](mailto:info@benchchem.com)

[Contact our Ph.D. Support Team for a compatibility check](#)

