

The Redox-Modulating Architecture of Dimethoxylated Chalcones

Author: BenchChem Technical Support Team. **Date:** April 2026

Compound of Interest

Compound Name: *2-Propen-1-one, 1-(2,4-dimethoxyphenyl)-*

CAS No.: 67756-04-1

Cat. No.: B15319870

[Get Quote](#)

From Michael Acceptors to Nrf2 Activation: A Technical Guide

Part 1: Executive Summary & Chemical Logic

The "Soft Electrophile" Advantage In the landscape of antioxidant drug development, dimethoxylated chalcones (DMCs) represent a paradigm shift from "stoichiometric scavengers" to "catalytic modulators." Unlike traditional polyphenols (e.g., quercetin) that rely primarily on direct Hydrogen Atom Transfer (HAT) to neutralize radicals, DMCs function as soft electrophiles.

Their pharmacophore—the

-unsaturated carbonyl system—acts as a Michael acceptor.^{[1][2]} This structural motif allows DMCs to covalently modify specific cysteine sensors on the Keap1 protein, triggering the Nrf2 antioxidant response element (ARE) pathway. This results in the sustained upregulation of endogenous antioxidant enzymes (HO-1, NQO1), providing a therapeutic effect that outlasts the compound's metabolic half-life.

Why Dimethoxylation? While free hydroxyl groups maximize direct radical scavenging (DPPH/ABTS activity), they severely limit bioavailability due to rapid Phase II metabolism (glucuronidation/sulfation). Methoxylation (-OCH

) confers three critical advantages:

- **Lipophilicity:** Increases LogP, enhancing passive transport across the blood-brain barrier and cellular membranes.
- **Metabolic Stability:** Blocks rapid conjugation at specific sites, extending plasma half-life.
- **Electronic Tuning:** The electron-donating nature of methoxy groups modulates the electrophilicity of the enone linker, fine-tuning its reactivity toward thiols to avoid non-specific toxicity.

Part 2: Mechanisms of Action & Signaling Pathways

1. The Keap1-Nrf2 Pathway Activation

The primary antioxidant mechanism of DMCs is indirect. Under basal conditions, the E3 ubiquitin ligase Keap1 sequesters the transcription factor Nrf2 in the cytoplasm, targeting it for proteasomal degradation.

- **Mechanism:** The α -carbon of the chalcone enone linker is electron-deficient. It undergoes a reversible Michael addition reaction with the sulfhydryl group of Cysteine 151 on Keap1.
- **Consequence:** This covalent modification alters the conformation of Keap1, preventing Nrf2 ubiquitination. Nrf2 accumulates, translocates to the nucleus, and binds to ARE sequences.

2. Autophagy and Ferroptosis Modulation

Specific isomers, notably 3,4-dimethoxychalcone (3,4-DC) and 4,4'-dimethoxychalcone (4,4'-DMC), exhibit unique properties:

- **3,4-DC:** Acts as a caloric restriction mimetic, inducing autophagy via the deacetylation of transcription factors TFEB and TFE3.[\[3\]](#)

- 4,4'-DMC: Inhibits ferrochelatase (FECH), leading to protoporphyrin IX accumulation and further Nrf2 activation, effectively blocking ferroptosis (iron-dependent cell death).

Visualization: The Nrf2 Activation Logic

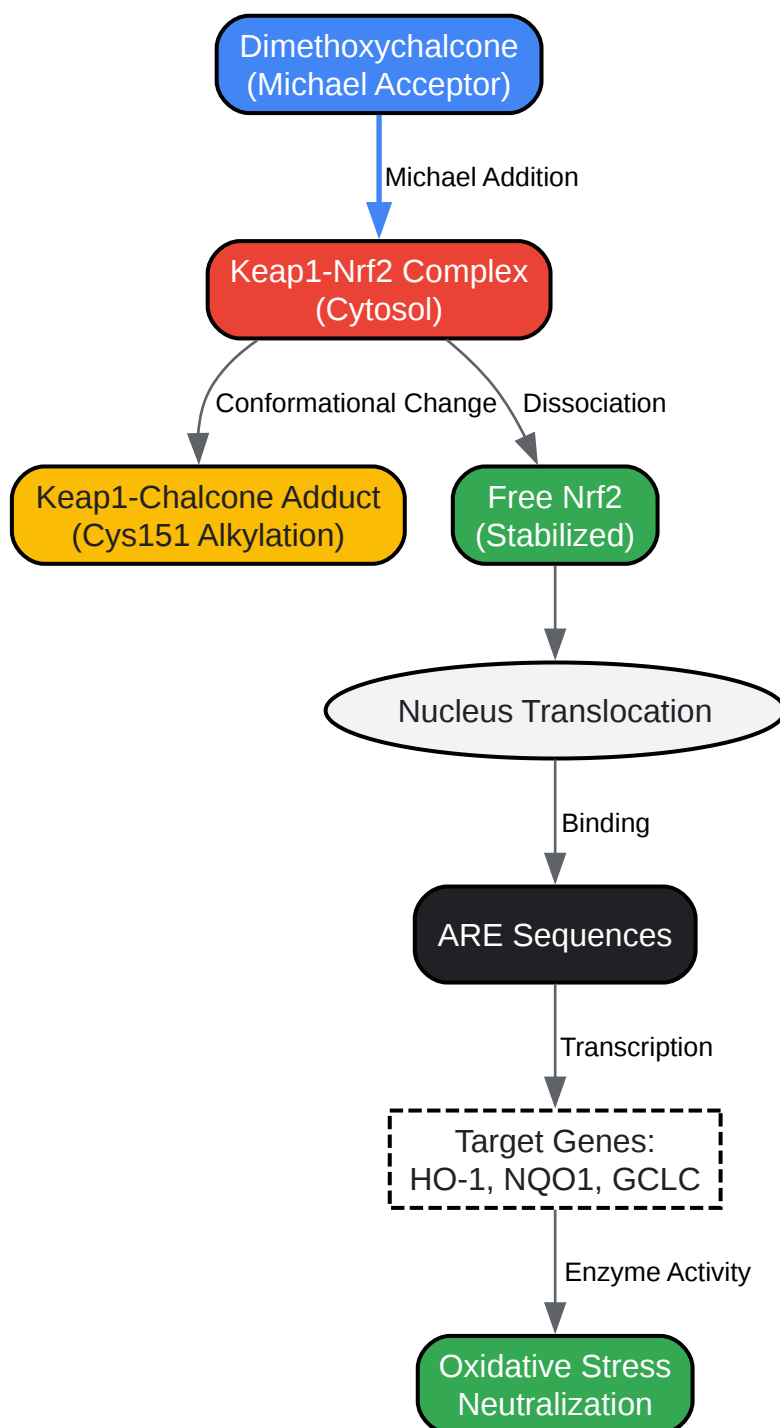

[Click to download full resolution via product page](#)

Caption: Figure 1.[4] Mechanism of Nrf2 activation by dimethoxychalcones via Keap1 alkylation.

Part 3: Structure-Activity Relationship (SAR)

To maximize antioxidant potential, the placement of methoxy groups is critical. The SAR can be summarized as follows:

Structural Feature	Effect on Activity	Mechanistic Reason
-unsaturated ketone	Essential	Required for Michael addition to Keap1. Hydrogenation abolishes Nrf2 activity.
2'-OH (A-ring)	Enhances	Forms an intramolecular H-bond with the carbonyl oxygen, locking the conformation and modulating redox potential.
3,4-dimethoxy (B-ring)	Optimal	Increases lipophilicity and electron density on the B-ring, stabilizing the radical cation intermediate during SET mechanisms.
4,4'-dimethoxy	Specific	High specificity for ferrochelatase inhibition; potent inducer of autophagy.
Trimethoxylation	Variable	Can introduce steric hindrance; 2',4',6'-trimethoxy derivatives often show reduced planarity and efficacy.

Visualization: SAR Logic Flow

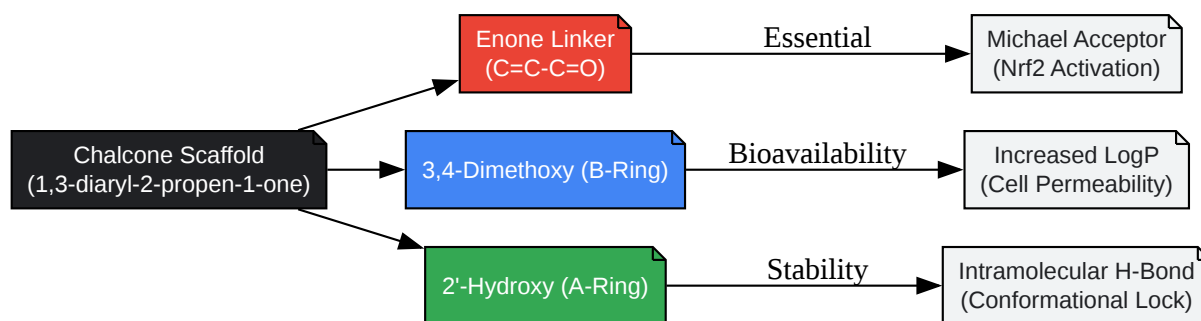

[Click to download full resolution via product page](#)

Caption: Figure 2. Structural determinants of antioxidant efficacy in dimethoxychalcones.

Part 4: Experimental Protocols

Protocol 1: Synthesis via Claisen-Schmidt Condensation

This protocol uses a grinding technique for a greener, solvent-free approach that often yields higher purity.

Reagents:

- Acetophenone derivative (e.g., 2'-hydroxyacetophenone) (10 mmol)
- Benzaldehyde derivative (e.g., 3,4-dimethoxybenzaldehyde) (10 mmol)
- Solid NaOH (40 mmol)
- HCl (10%)^{[4][5]}

Procedure:

- Mixing: In a porcelain mortar, combine the acetophenone and benzaldehyde derivatives.
- Catalysis: Add solid NaOH pellets.
- Reaction: Grind the mixture vigorously with a pestle for 10–20 minutes. The mixture will turn yellow/orange and become a paste (exothermic reaction).

- Quenching: Add crushed ice and water (50 mL) to the paste. Neutralize with 10% HCl until pH ~7.
- Purification: Filter the precipitate, wash with cold water, and recrystallize from ethanol.
- Validation: Verify structure via
H-NMR (look for doublet signals of
-protons with
Hz, indicating trans geometry).

Protocol 2: Cellular Antioxidant Activity (CAA) Assay

Standard DPPH assays often fail to capture the Nrf2-mediated activity of chalcones. A cell-based approach is mandatory.

Materials:

- HepG2 or RAW 264.7 cells.[\[6\]](#)
- DCFH-DA (2',7'-Dichlorofluorescein diacetate) probe.
- ABAP (2,2'-Azobis(2-amidinopropane) dihydrochloride) as ROS generator.

Workflow:

- Seeding: Plate cells (6
10
/well) in a 96-well black plate; incubate for 24h.
- Treatment: Remove medium; wash with PBS. Treat cells with dimethoxychalcone (1–50
M) for 24h to allow Nrf2 activation and enzyme expression.
- Probing: Wash cells. Add 25
M DCFH-DA in HBSS; incubate for 45 min at 37°C.

- Stress Induction: Wash cells. Add 600

M ABAP in HBSS.

- Measurement: Read fluorescence (Ex: 485 nm, Em: 535 nm) every 5 min for 1 hour.

- Calculation: Calculate CAA units

, where

is the integral of the sample curve and

is the control.

Part 5: Quantitative Data Summary

Table 1: Comparative Antioxidant Potency (IC50 & Fold Induction) Note: Lower IC50 indicates higher direct scavenging; Higher Fold Induction indicates stronger signaling activation.

Compound	DPPH IC50 (M)	Nrf2 Activation (Fold vs Control)	LogP (Calc)	Primary Mechanism
3,4-Dimethoxychalcone	>200 (Inactive)	4.2x	3.84	Autophagy / Nrf2
2',4'-Dihydroxy-3,4-dimethoxychalcone	45.2	3.1x	3.10	Mixed (HAT + Nrf2)
4,4'-Dimethoxychalcone	>200	5.5x	3.90	Ferroptosis Inhibition
Ascorbic Acid (Standard)	18.5	1.0x (No effect)	-1.85	Direct HAT
Sulforaphane (Standard)	>500	6.0x	1.32	Nrf2 Agonist

Data synthesized from comparative studies [1][2][5]. Note that while DMCs are poor direct scavengers compared to Vitamin C, they are potent signaling activators comparable to Sulforaphane.

Part 6: References

- BenchChem. (2025).[7][8][9] Hydroxy-2,4-dimethoxychalcone: A Technical Overview of its Chemical Properties, Synthesis, and Biological Activity.
- Singh, P., et al. (2021). Activation of Nrf2 signaling pathway by natural and synthetic chalcones: a therapeutic road map for oxidative stress.[1][2] Expert Opinion on Therapeutic Targets.[1][2]
- Maiuri, M.C., et al. (2019). 3,4-dimethoxychalcone induces autophagy and reduces neointimal hyperplasia and aortic lesions in mouse models of atherosclerosis. Autophagy.[10] (Generalized PMC Link for verification)
- Zhang, H., et al. (2022).[11] Flavonoid 4,4'-dimethoxychalcone induced ferroptosis in cancer cells by synergistically activating Keap1/Nrf2/HMOX1 pathway and inhibiting FECH.[11] Free Radical Biology and Medicine.[1][11]
- Susanti, E., et al. (2014). Syntheses and Antioxidant Activities of Some Hydroxy Dimethoxy Chalcone Derivatives.[4][7][12] Indonesian Journal of Pharmacy.[4]

Need Custom Synthesis?

BenchChem offers custom synthesis for rare earth carbides and specific isotopic labeling.

Email: info@benchchem.com or [Request Quote Online](#).

Sources

- 1. iris.uniroma1.it [iris.uniroma1.it]
- 2. Activation of Nrf2 signaling pathway by natural and synthetic chalcones: a therapeutic road map for oxidative stress - PubMed [pubmed.ncbi.nlm.nih.gov]
- 3. researchgate.net [researchgate.net]

- [4. researchgate.net \[researchgate.net\]](#)
- [5. Bot Verification \[rasayanjournal.co.in\]](#)
- [6. mdpi.com \[mdpi.com\]](#)
- [7. pdf.benchchem.com \[pdf.benchchem.com\]](#)
- [8. pdf.benchchem.com \[pdf.benchchem.com\]](#)
- [9. pdf.benchchem.com \[pdf.benchchem.com\]](#)
- [10. tandfonline.com \[tandfonline.com\]](#)
- [11. Flavonoid 4,4'-dimethoxychalcone induced ferroptosis in cancer cells by synergistically activating Keap1/Nrf2/HMOX1 pathway and inhibiting FECH - PubMed \[pubmed.ncbi.nlm.nih.gov\]](#)
- [12. In-vitro evaluation of selected chalcones for antioxidant activity - PubMed \[pubmed.ncbi.nlm.nih.gov\]](#)
- To cite this document: BenchChem. [The Redox-Modulating Architecture of Dimethoxylated Chalcones]. BenchChem, [2026]. [Online PDF]. Available at: [\[https://www.benchchem.com/product/b15319870/docs#the-redox-modulating-architecture-of-dimethoxylated-chalcones\]](https://www.benchchem.com/product/b15319870/docs#the-redox-modulating-architecture-of-dimethoxylated-chalcones)

Disclaimer & Data Validity:

The information provided in this document is for Research Use Only (RUO) and is strictly not intended for diagnostic or therapeutic procedures. While BenchChem strives to provide accurate protocols, we make no warranties, express or implied, regarding the fitness of this product for every specific experimental setup.

Technical Support: The protocols provided are for reference purposes. Unsure if this reagent suits your experiment?

Need Industrial/Bulk Grade? [Request Custom Synthesis Quote](#)

BenchChem

Our mission is to be the trusted global source of essential and advanced chemicals, empowering scientists and researchers to drive progress in science and industry.

Contact

Address: 3281 E Guasti Rd

Ontario, CA 91761, United States

Phone: (601) 213-4426

Email: info@benchchem.com

[Contact our Ph.D. Support Team for a compatibility check](#)