

# Application Note: Strategic Introduction of Difluoromethyl ( ) Groups onto Pyrazoles

**Author:** BenchChem Technical Support Team. **Date:** May 2026

## Compound of Interest

Compound Name: 2-(1-(Difluoromethyl)-1h-pyrazol-4-yl)aniline

Cat. No.: B15316009

[Get Quote](#)

## Executive Summary: The "Lipophilic Hydrogen Bond Donor"

The difluoromethyl group (

) is a privileged motif in modern medicinal chemistry. Unlike the chemically inert trifluoromethyl group (

), the

moiety acts as a lipophilic hydrogen bond donor. The C–H bond is polarized by the two fluorine atoms, allowing it to function as a weak hydrogen bond donor (bioisostere of alcohols

and thiols

) while simultaneously increasing metabolic stability and lipophilicity (LogD).

For pyrazoles—a scaffold ubiquitous in kinase inhibitors and anti-inflammatory agents—the introduction of a

group can drastically alter the pharmacological profile. This guide details the three primary methodologies for this transformation:

- Innate C-H Functionalization (Radical mechanisms via Zinc Sulfinates).
- N-Difluoromethylation (Difluorocarbene insertion).
- Photoredox Catalysis (Late-stage functionalization).

## Decision Matrix: Selecting the Right Reagent

Before selecting a protocol, analyze the substrate's electronic and steric environment.

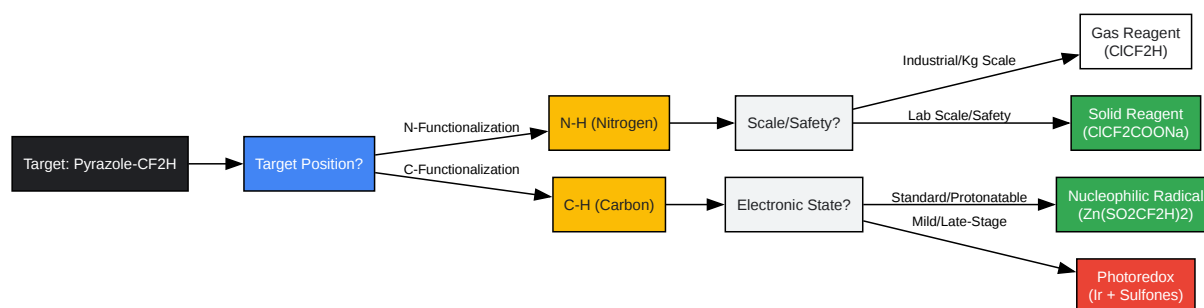

[Click to download full resolution via product page](#)

Figure 1: Decision matrix for selecting the optimal difluoromethylation strategy.

## Method A: Direct C-H Difluoromethylation (Radical)

Primary Reagent: Zinc Difluoromethanesulfinate (DFMS, Baran's Reagent) Mechanism:

Minisci-type Radical Substitution

This is the gold standard for late-stage functionalization of existing pyrazole cores. The reaction relies on the generation of a

radical.

## Expert Insight: The Role of Protonation

The

radical exhibits nucleophilic character (unlike the electrophilic

). Therefore, it reacts best with electron-deficient heterocycles. Pyrazoles are inherently electron-rich.

- **Critical Step:** You typically must add Trifluoroacetic Acid (TFA) or use a biphasic system with an acidic aqueous layer. Protonation of the pyrazole nitrogen ( ) renders the ring electron-deficient, activating it toward nucleophilic radical attack.

## Protocol 1: DFMS-Mediated C-H Difluoromethylation[1]

Reagents:

- Substrate: Pyrazole derivative (1.0 equiv)
- Reagent: Zinc Difluoromethanesulfinate (DFMS) (3.0 equiv)
- Oxidant: tert-Butyl hydroperoxide (TBHP), 70% aq. (5.0 equiv)
- Solvent: DCM / Water (2.5:1 ratio)
- Additive: TFA (1.0 equiv) – Optional but recommended for unactivated pyrazoles.

Step-by-Step Methodology:

- **Setup:** To a vial equipped with a stir bar, add the pyrazole substrate (0.5 mmol) and DFMS (1.5 mmol, 440 mg).
- **Solvent:** Add Dichloromethane (DCM, 1.0 mL) and Water (0.4 mL).
  - **Note:** The biphasic system helps solubilize the inorganic salts and the organic substrate while moderating the exotherm.
- **Activation:** Add TFA (0.5 mmol, 38  $\mu$ L) if the substrate does not contain an electron-withdrawing group (EWG).

- Initiation: Add TBHP (70% in water) dropwise (2.5 mmol) at 0°C, then warm to Room Temperature (23°C).
  - Caution: TBHP is an oxidant. Ensure proper venting as gas ( ) is evolved.
- Monitoring: Stir vigorously for 12–24 hours.
  - Self-Validation: If conversion stalls (<50%), add a second portion of DFMS (1.0 equiv) and TBHP (1.5 equiv).
- Workup: Quench with saturated aq. (careful, gas evolution). Extract with DCM (3x). Dry over , concentrate, and purify via column chromatography.

## Method B: N-Difluoromethylation

Primary Reagent: Sodium Chlorodifluoroacetate (

) or Chlorodifluoromethane (

, Freon-22) Mechanism: Difluorocarbene (

) Insertion

Direct N-alkylation is achieved via the in situ generation of difluorocarbene. While

gas is cheap, it is difficult to handle in standard labs. The solid reagent

is preferred for safety and ease of handling.

## Expert Insight: Regioselectivity Challenges

N-difluoromethylation of asymmetric pyrazoles often yields a mixture of N1- and N2-isomers (e.g., 1:1 to 3:1 ratios).

- **\*\* steric control:\*\*** The carbene mechanism is sensitive to sterics. Bulky groups at C3/C5 can shift selectivity.

- Thermodynamics: Unlike standard alkylation ( ), carbene insertion is fast. Isomer separation by chromatography is often required.

## Protocol 2: Solid-Source N-Difluoromethylation

### Reagents:

- Substrate: Pyrazole (1.0 equiv)
- Reagent: Sodium chlorodifluoroacetate (2.0 – 3.0 equiv)
- Base:  
(2.0 equiv)
- Solvent: DMF or DMF/Water (10:1)
- Temperature: 90–100°C

### Step-by-Step Methodology:

- Dissolution: Dissolve the pyrazole (1.0 mmol) and (2.0 mmol) in DMF (5 mL).
- Reagent Addition: Add Sodium chlorodifluoroacetate (1.5 mmol) in a single portion.
- Heating: Heat the mixture to 95°C.
  - Mechanism Check: The reagent decarboxylates at this temperature to release .
- Iterative Addition: To maximize yield and minimize decomposition of the carbene before reaction, add the remaining reagent (1.5 mmol) in portions over 1 hour.
- Workup: Cool to RT. Dilute with water (excess DMF causes emulsion; use ample water). Extract with Ethyl Acetate.

- Purification: Silica gel chromatography is essential to separate N-isomers.

## Method C: Photoredox Catalysis (Mild Conditions)

Primary Reagent: Difluoromethyl sulfones or Phosphonium salts (

) Catalyst:

or Eosin Y (Metal-free)

For substrates sensitive to the oxidative conditions of the DFMS method (e.g., those containing oxidizable amines or sulfurs), photoredox is the superior choice.

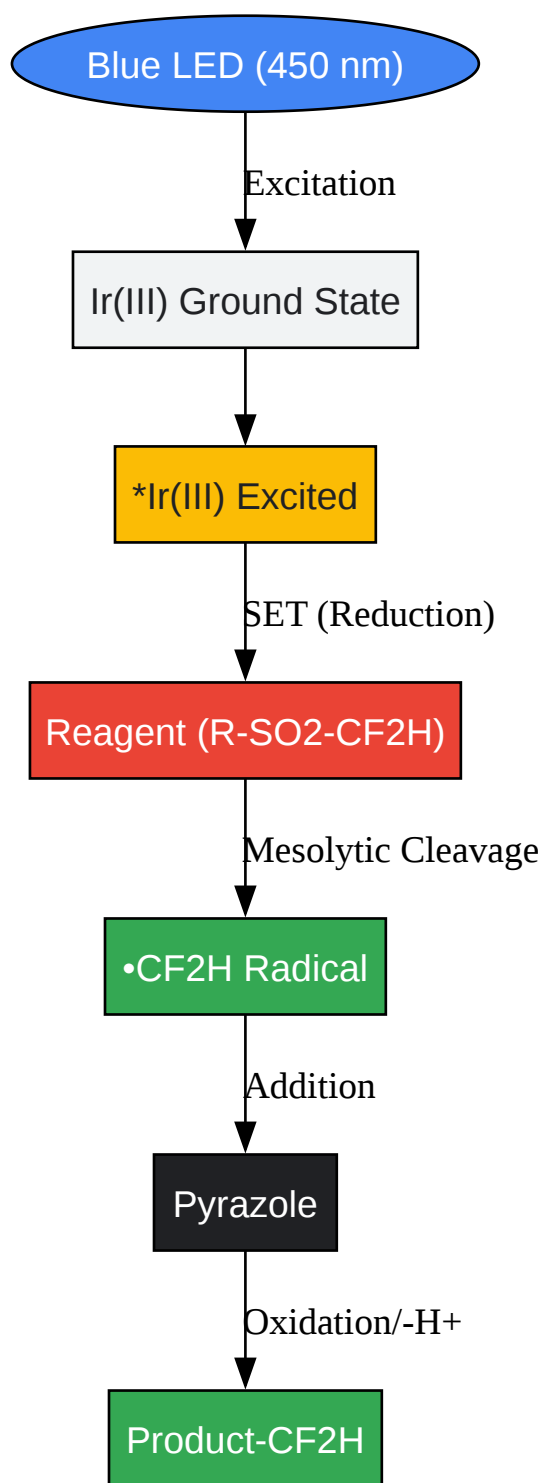

[Click to download full resolution via product page](#)

Figure 2: Simplified Photoredox Cycle for Radical Generation.

## Comparative Data: Reagent Selection Guide

Feature	Zinc Sulfinate (DFMS)	Chlorodifluoroacetate	Photoredox Reagents
Primary Target	C-H (Carbon)	N-H (Nitrogen)	C-H (Carbon)
Mechanism	Radical (Nucleophilic)	Carbene Insertion	Radical (SET)
Conditions	Oxidative (TBHP), Acidic	Basic, High Temp (95°C)	Mild, Blue Light
Cost	Moderate	Low	High (Catalyst cost)
Scalability	High (Kg scale proven)	High	Low/Medium (Flow chem needed)
Key Limitation	Regioselectivity on neutral rings	N-isomer mixtures	Catalyst removal

## Troubleshooting & Optimization (Self-Validating Systems)

- Reaction Stalls (DFMS Method):
  - Diagnosis: The radical half-life is short.
  - Fix: Do not add all reagents at once. Portion-wise addition of TBHP and DFMS over 4 hours maintains a steady-state radical concentration.
- Poor Reactivity (N-Alkylation):
  - Diagnosis: "Dry" DMF often suppresses carbene solubility/activity if using salts.
  - Fix: Add 5-10% water to the DMF. The presence of trace water helps solvate the inorganic base and facilitates the decarboxylation/anion transfer.
- Regioselectivity Issues (C-H Functionalization):
  - Insight: If C3 and C5 are both open, the reaction prefers the position with lower electron density.

- Modification: If the wrong isomer is formed, block the reactive site with a halogen (Br/I) or use a directing group strategy (though DG strategies are less developed for than ).

## References

- Fujiwara, Y., Dixon, J. A., O'Hara, F., Funder, E. D., Dixon, D. D., & Baran, P. S. (2012). Practical and innate carbon–hydrogen functionalization of heterocycles. *Nature*, 492(7427), 95–99. [[Link](#)]
- Li, L., Ni, C., Xie, Q., & Hu, J. (2017). Difluoromethyl 2-Pyridyl Sulfone: A New Reagent for Palladium-Catalyzed Cross-Coupling of Aryl Boronic Acids. *Angewandte Chemie International Edition*, 56(33), 9971–9975. [[Link](#)]
- Prakash, G. K. S., & Hu, J. (2004).[1] Selective Fluoroalkylation of Organic Compounds: Nucleophilic Difluoromethylation.[2][3] *Accounts of Chemical Research*, 51(12), 2954–2967. [[Link](#)]
- Beatty, J. W., Douglas, J. J., Cole, K. P., & Stephenson, C. R. J. (2015). A Photochemical Strategy for the C–H Difluoromethylation of Heteroarenes. *Nature Communications*, 6, 7919. [[Link](#)]
- Zafrani, Y., Sod-Moriah, G., & Segall, Y. (2009).[1][4] Diethyl (bromodifluoromethyl)phosphonate: A highly efficient and stable source of difluorocarbene. *Tetrahedron*, 65(27), 5278-5283. [[Link](#)]

### Need Custom Synthesis?

BenchChem offers custom synthesis for rare earth carbides and specific isotopic labeling.

Email: [info@benchchem.com](mailto:info@benchchem.com) or [Request Quote Online](#).

## Sources

- [1. Difluoromethylating Reagents | Tokyo Chemical Industry \(India\) Pvt. Ltd. \[tcichemicals.com\]](#)
- [2. A New Reagent for Direct Difluoromethylation - PMC \[pmc.ncbi.nlm.nih.gov\]](#)
- [3. alfa-chemistry.com \[alfa-chemistry.com\]](#)
- [4. tcichemicals.com \[tcichemicals.com\]](#)
- To cite this document: BenchChem. [Application Note: Strategic Introduction of Difluoromethyl ( ) Groups onto Pyrazoles]. BenchChem, [2026]. [Online PDF]. Available at: [<https://www.benchchem.com/product/b15316009/docs#application-note-strategic-introduction-of-difluoromethyl-groups-onto-pyrazoles>]

---

### Disclaimer & Data Validity:

The information provided in this document is for Research Use Only (RUO) and is strictly not intended for diagnostic or therapeutic procedures. While BenchChem strives to provide accurate protocols, we make no warranties, express or implied, regarding the fitness of this product for every specific experimental setup.

**Technical Support:** The protocols provided are for reference purposes. Unsure if this reagent suits your experiment?

**Need Industrial/Bulk Grade?** [Request Custom Synthesis Quote](#)

## BenchChem

Our mission is to be the trusted global source of essential and advanced chemicals, empowering scientists and researchers to drive progress in science and industry.

### Contact

Address: 3281 E Guasti Rd  
Ontario, CA 91761, United States  
Phone: (601) 213-4426  
Email: [info@benchchem.com](mailto:info@benchchem.com)

Contact our Ph.D. Support Team for a compatibility check