

Introduction: The Enduring Relevance of the Ullmann Coupling in Modern Synthesis

Author: BenchChem Technical Support Team. **Date:** April 2026

Compound of Interest

Compound Name: 4-[2-(Methylsulfanyl)phenoxy]benzoic acid

Cat. No.: B15306293

[Get Quote](#)

The diaryl ether linkage is a cornerstone structural motif in a multitude of molecules critical to the pharmaceutical, agrochemical, and materials science sectors. Phenoxybenzoic acids, in particular, serve as vital intermediates in the synthesis of compounds with diverse biological activities. While modern organic synthesis offers several methods for constructing the C-O aryl bond, including the Nobel Prize-winning palladium-catalyzed Buchwald-Hartwig amination, the Ullmann coupling reaction remains a highly relevant and powerful tool.^{[1][2]} First reported by Fritz Ullmann in the early 20th century, this copper-catalyzed reaction offers a cost-effective and practical alternative, particularly for large-scale industrial applications where the expense of palladium and its associated phosphine ligands can be prohibitive.^{[3][4][5]}

Historically, the Ullmann condensation was plagued by harsh reaction conditions, often requiring temperatures exceeding 200°C and stoichiometric amounts of copper powder, which limited its substrate scope and functional group tolerance.^{[6][7][8]} However, the last two decades have witnessed a renaissance of the Ullmann reaction. The introduction of catalytic amounts of soluble copper(I) salts in combination with rationally designed ligands has dramatically transformed its utility, enabling these couplings to proceed under significantly milder conditions with a much broader range of substrates.^{[9][10]}

This guide provides researchers, scientists, and drug development professionals with a comprehensive overview and practical protocols for the synthesis of phenoxybenzoic acids via the modern Ullmann coupling. We will delve into the mechanistic underpinnings of the reaction, explore the critical parameters that govern its success, and offer a detailed, field-proven experimental protocol.

The Catalytic Cycle: A Mechanistic Overview

While the precise mechanism of the Ullmann reaction has been the subject of extensive study and can vary with different catalytic systems, a generally accepted pathway for the ligand-assisted C-O coupling is illustrated below.^{[4][11]} The cycle is believed to involve Cu(I)/Cu(III) intermediates.

- **Phenoxide Formation:** The reaction commences with the deprotonation of the phenol by a base to form the corresponding alkali phenoxide, which is the active nucleophile.
- **Ligand Association:** The ligand coordinates to the Cu(I) salt, forming a more soluble and reactive catalytic species.
- **Oxidative Addition:** The aryl halide undergoes oxidative addition to the Cu(I) complex, forming a transient, high-valent Cu(III) intermediate. The ortho-carboxy group of a halobenzoic acid can play a crucial role here, acting as an ancillary ligand that facilitates this step.^[6]
- **Reductive Elimination:** The Cu(III) intermediate undergoes reductive elimination, forming the desired C-O bond of the diaryl ether product and regenerating the active Cu(I) catalyst, which re-enters the catalytic cycle.

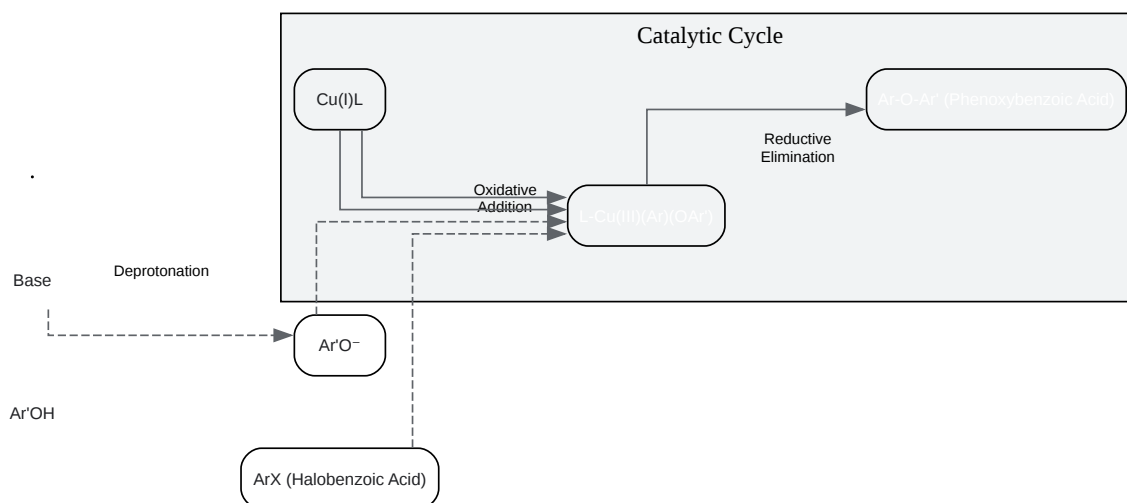

[Click to download full resolution via product page](#)

Caption: Proposed catalytic cycle for the Ullmann diaryl ether synthesis.

Optimizing Reaction Conditions: A Guide to Key Parameters

The success of a modern Ullmann coupling hinges on the careful selection and optimization of several key parameters. The interplay between the copper source, ligand, base, and solvent dictates the reaction's efficiency, yield, and substrate compatibility.

Parameter	Common Choices	Rationale and Expert Insights
Copper Source	CuI, Cu ₂ O, CuBr, CuCl, Copper Powder (classical)	<p>Copper(I) iodide (CuI) is the most frequently used precursor due to its reliability and commercial availability.[12]</p> <p>Cu₂O is also highly effective.[5]</p> <p>The key is to use a Cu(I) source, which is the active oxidation state for initiating the catalytic cycle. While classical methods used copper powder, these required very high temperatures and stoichiometric amounts.[7]</p> <p>Modern catalytic protocols typically employ 1-10 mol% of the copper salt.</p>
Ligand	N,N-Ligands: 1,10-Phenanthroline, N,N'-Dimethylethylenediamine (DMEDA) N,O-Ligands: L-Proline, N,N-Dimethylglycine[2][3] Oxalic Diamides[9]	<p>Ligands are crucial for accelerating the reaction and enabling milder conditions.[6]</p> <p>They enhance the solubility of the copper species and facilitate the oxidative addition and reductive elimination steps. N,N-Dimethylglycine and L-proline are excellent, inexpensive, and robust ligands for coupling phenols with aryl bromides and iodides. [2][3] For more challenging substrates, such as aryl chlorides, more sophisticated ligands like oxalic diamides may be necessary.[9] Ligand screening is often required for</p>

novel or complex substrates.

[3]

Base

K_3PO_4 , Cs_2CO_3 , K_2CO_3 , KOH

The base's primary role is to deprotonate the phenol, generating the nucleophilic phenoxide. Potassium phosphate (K_3PO_4) and cesium carbonate (Cs_2CO_3) are highly effective bases for C-O coupling reactions.[3][12] Cs_2CO_3 is often superior in terms of yield and reaction rate but is more expensive.[5] The base must be anhydrous, as water can inhibit the reaction. It is often recommended to flame-dry the flask and dry the base in an oven prior to use.

Solvent

DMF, DMSO, NMP, Toluene, Acetonitrile, Pyridine

Traditional Ullmann reactions required high-boiling polar aprotic solvents like N-methylpyrrolidone (NMP) or dimethylformamide (DMF) to reach the necessary temperatures.[7][13] Modern ligand-accelerated systems can be run at lower temperatures (80-120 °C), expanding the solvent scope to include options like acetonitrile or toluene.[3][14] The choice of solvent should be guided by the required reaction temperature and the solubility of the reactants and catalyst system.

Aryl Halide	Aryl Iodides, Aryl Bromides, Aryl Chlorides	Reactivity follows the trend $I > Br \gg Cl$. ^[15] Aryl iodides and bromides are the most common substrates. Electron-withdrawing groups on the aryl halide generally accelerate the reaction. ^[7] The synthesis of phenoxybenzoic acids typically involves the coupling of a phenol with a halobenzoic acid (e.g., 2-chlorobenzoic acid or 3-bromobenzoic acid). ^[16]
-------------	--	--

Experimental Protocol: Synthesis of 3-Phenoxybenzoic Acid

This protocol provides a detailed, step-by-step method for the synthesis of 3-phenoxybenzoic acid from 3-bromobenzoic acid and phenol, a representative example of the Ullmann coupling.

Materials:

- 3-Bromobenzoic acid (1.0 mmol, 201 mg)
- Phenol (1.2 mmol, 113 mg)
- Copper(I) iodide (CuI) (0.1 mmol, 19 mg, 10 mol%)
- N,N-Dimethylglycine (0.2 mmol, 21 mg, 20 mol%)
- Potassium phosphate (K_3PO_4), anhydrous (2.0 mmol, 424 mg)
- Anhydrous Dimethylformamide (DMF) (3-5 mL)
- Argon or Nitrogen gas supply
- Standard laboratory glassware (Schlenk flask or oven-dried round-bottom flask with condenser)

- Magnetic stirrer and heating mantle

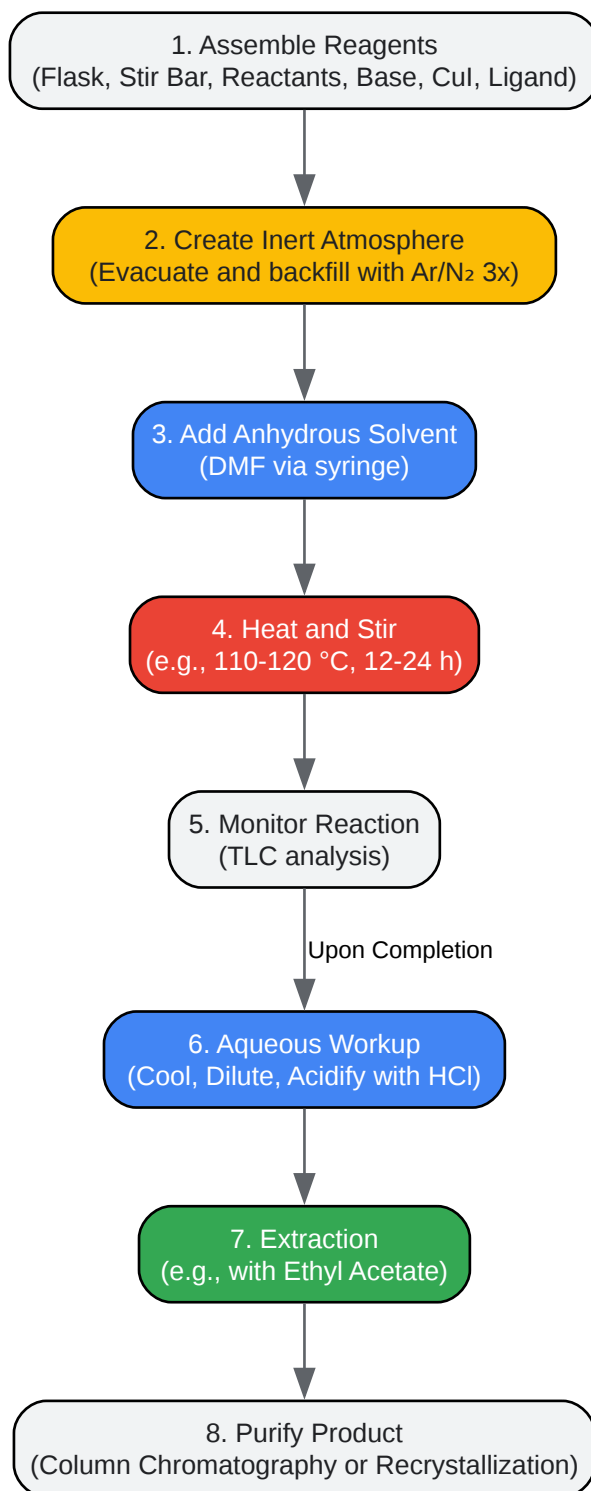

[Click to download full resolution via product page](#)

Caption: General experimental workflow for Ullmann C-O coupling.

Procedure:

- **Reaction Setup:** To a flame-dried Schlenk flask equipped with a magnetic stir bar and a reflux condenser, add 3-bromobenzoic acid (201 mg), phenol (113 mg), anhydrous potassium phosphate (424 mg), copper(I) iodide (19 mg), and N,N-dimethylglycine (21 mg).
- **Inert Atmosphere:** Seal the flask with a septum. Evacuate the flask under vacuum and backfill with an inert gas (Argon or Nitrogen). Repeat this cycle three times to ensure all oxygen is removed.[\[12\]](#)
- **Solvent Addition:** Under a positive pressure of the inert gas, add anhydrous DMF (4 mL) via syringe.
- **Reaction:** Lower the flask into a pre-heated oil bath at 120 °C. Stir the mixture vigorously. The reaction mixture will typically turn from a pale suspension to a darker, more homogeneous solution.
- **Monitoring:** Monitor the reaction progress by thin-layer chromatography (TLC). To take a sample, briefly remove the flask from heat, allow it to cool slightly, and quickly withdraw a small aliquot with a syringe. Spot the sample on a TLC plate against the starting materials.
- **Workup:** Once the reaction is complete (typically 12-24 hours, as determined by TLC), allow the mixture to cool to room temperature. Dilute the reaction mixture with water (20 mL) and transfer it to a separatory funnel.
- **Acidification and Extraction:** Acidify the aqueous mixture to a pH of ~2 using 2M hydrochloric acid (HCl). This step protonates the carboxylate product, making it soluble in organic solvents. Extract the product with ethyl acetate (3 x 20 mL).
- **Drying and Concentration:** Combine the organic layers, wash with brine (1 x 20 mL), dry over anhydrous sodium sulfate (Na₂SO₄), filter, and concentrate the solvent under reduced pressure using a rotary evaporator.
- **Purification:** The crude product can be purified by silica gel column chromatography or by recrystallization from a suitable solvent system (e.g., ethanol/water) to yield pure 3-phenoxybenzoic acid.

Troubleshooting Guide

Issue	Probable Cause(s)	Recommended Solution(s)
No or Low Conversion	1. Inactive catalyst (oxidized CuI). 2. Presence of water or oxygen. 3. Insufficiently strong base or wet base. 4. Reaction temperature is too low.	1. Use high-purity CuI from a fresh bottle. 2. Ensure rigorous inert atmosphere technique; use anhydrous solvents and oven-dried glassware/base. 3. Switch to a stronger base like Cs ₂ CO ₃ ; ensure the base is thoroughly dried before use. 4. Increase the reaction temperature in 10 °C increments.
Formation of Side Products	1. Homocoupling of the aryl halide (biaryl formation). 2. Reduction of the aryl halide (dehalogenation).	1. This can occur at very high temperatures. Try lowering the temperature. Ensure the correct stoichiometry of phenol is used (often a slight excess is beneficial). 2. Ensure the solvent is truly anhydrous and the inert atmosphere is maintained.
Difficulty in Purification	1. Residual copper catalyst in the product. 2. Product is an oil instead of a solid.	1. During workup, washing the organic layer with an aqueous solution of ammonium hydroxide or EDTA can help chelate and remove residual copper salts. 2. Attempt purification via column chromatography. If an oil persists, try triturating with a non-polar solvent like hexane to induce crystallization.

Conclusion

The modern, ligand-assisted Ullmann coupling is an indispensable reaction for the synthesis of phenoxybenzoic acids and other diaryl ethers. By understanding the mechanistic principles and carefully controlling the key reaction parameters—catalyst, ligand, base, and solvent—researchers can achieve high yields under relatively mild conditions. The cost-effectiveness and operational simplicity of this method ensure its continued and widespread use in both academic research and industrial drug development.

References

- RECENT SYNTHETIC DEVELOPMENTS AND APPLICATIONS OF THE ULLMANN REACTION. A REVIEW - PMC. (n.d.). National Center for Biotechnology Information. [\[Link\]](#)
- Ullmann Reaction - Organic Chemistry Portal. (n.d.). Organic Chemistry Portal. [\[Link\]](#)
- Screening of ligands for the Ullmann synthesis of electron-rich diaryl ethers - PMC. (2012, July 17). National Center for Biotechnology Information. [\[Link\]](#)
- Modern Ullmann-Type Couplings. (n.d.). ResearchGate. [\[Link\]](#)
- Ullmann condensation - Wikipedia. (n.d.). Wikipedia. [\[Link\]](#)
- Copper catalysed Ullmann type chemistry: from mechanistic aspects to modern development. (2014, March 3). Royal Society of Chemistry. [\[Link\]](#)
- Ullmann Condensation. (n.d.). SynArchive. [\[Link\]](#)
- Ullmann reaction - Wikipedia. (n.d.). Wikipedia. [\[Link\]](#)
- Ullmann coupling-An overview. (2025, April 1). OperaChem. [\[Link\]](#)
- A General and Mild Ullmann-Type Synthesis of Diaryl Ethers. (n.d.). Organic Chemistry Portal. [\[Link\]](#)
- Ullmann Coupling & other Cu Catalyzed reactions. (n.d.). Organic Synthesis. [\[Link\]](#)

- Ullmann reaction | 696 Publications | 8114 Citations | Top Authors | Related Topics. (n.d.). SciSpace. [\[Link\]](#)
- Recent Progress in Diaryl Ether Synthesis. (n.d.). ResearchGate. [\[Link\]](#)
- Recent Advancement of Ullmann Condensation Coupling Reaction in the Formation of Aryl-Oxygen (CO) Bonding by Copper-Mediated Catalyst. (2020, September 24). Semantic Scholar. [\[Link\]](#)
- Process for preparation of 4-(4-phenoxyphenoxy) benzoic acid by oxidation of 1-(4-methylphenoxy)-4-phenoxybenzene. (2004, September 8).
- Diaryl ether synthesis by etherification (arylation). (n.d.). Organic Chemistry Portal. [\[Link\]](#)
- Formation of Aryl-Carbon and Aryl-Heteroatom Bonds Using Copper(I) Catalysts. (n.d.). University of Pennsylvania ScholarlyCommons. [\[Link\]](#)
- Process for preparing phenoxybenzoic acids. (n.d.).
- Aerobic Copper-Catalyzed Organic Reactions. (n.d.). SciSpace. [\[Link\]](#)
- Copper-catalyzed synthesis of primary amides through reductive N–O cleavage of dioxazolones - PMC. (2024, March 20). National Center for Biotechnology Information. [\[Link\]](#)
- Recent Advancement of Ullmann Condensation Coupling Reaction in the Formation of Aryl-Oxygen (C-O) Bonding by Copper-Mediated Catalyst. (2020, September 24). MDPI. [\[Link\]](#)

Need Custom Synthesis?

BenchChem offers custom synthesis for rare earth carbides and specific isotopic labeling.

Email: info@benchchem.com or [Request Quote Online](#).

Sources

- 1. [researchgate.net](https://www.researchgate.net) [[researchgate.net](https://www.researchgate.net)]
- 2. [Diaryl ether synthesis by etherification \(arylation\)](https://www.organic-chemistry.org) [[organic-chemistry.org](https://www.organic-chemistry.org)]

- [3. Screening of ligands for the Ullmann synthesis of electron-rich diaryl ethers - PMC \[pmc.ncbi.nlm.nih.gov\]](#)
- [4. Ullmann reaction - Wikipedia \[en.wikipedia.org\]](#)
- [5. A General and Mild Ullmann-Type Synthesis of Diaryl Ethers \[organic-chemistry.org\]](#)
- [6. RECENT SYNTHETIC DEVELOPMENTS AND APPLICATIONS OF THE ULLMANN REACTION. A REVIEW - PMC \[pmc.ncbi.nlm.nih.gov\]](#)
- [7. Ullmann condensation - Wikipedia \[en.wikipedia.org\]](#)
- [8. pdfs.semanticscholar.org \[pdfs.semanticscholar.org\]](#)
- [9. researchgate.net \[researchgate.net\]](#)
- [10. Copper catalysed Ullmann type chemistry: from mechanistic aspects to modern development - Chemical Society Reviews \(RSC Publishing\) \[pubs.rsc.org\]](#)
- [11. Ullmann Reaction \[organic-chemistry.org\]](#)
- [12. pdf.benchchem.com \[pdf.benchchem.com\]](#)
- [13. synarchive.com \[synarchive.com\]](#)
- [14. organic-synthesis.com \[organic-synthesis.com\]](#)
- [15. mdpi.com \[mdpi.com\]](#)
- [16. scispace.com \[scispace.com\]](#)
- [To cite this document: BenchChem. \[Introduction: The Enduring Relevance of the Ullmann Coupling in Modern Synthesis\]. BenchChem, \[2026\]. \[Online PDF\]. Available at: \[https://www.benchchem.com/product/b15306293/docs#introduction-the-enduring-relevance-of-the-ullmann-coupling-in-modern-synthesis\]](#)

Disclaimer & Data Validity:

The information provided in this document is for Research Use Only (RUO) and is strictly not intended for diagnostic or therapeutic procedures. While BenchChem strives to provide accurate protocols, we make no warranties, express or implied, regarding the fitness of this product for every specific experimental setup.

Technical Support: The protocols provided are for reference purposes. Unsure if this reagent suits your experiment?

Need Industrial/Bulk Grade? [Request Custom Synthesis Quote](#)

BenchChem

Our mission is to be the trusted global source of essential and advanced chemicals, empowering scientists and researchers to drive progress in science and industry.

Contact

Address: 3281 E Guasti Rd

Ontario, CA 91761, United States

Phone: (601) 213-4426

Email: info@benchchem.com

[Contact our Ph.D. Support Team for a compatibility check](#)