

Technical Support Center: Fluorinated Azepane Purification

Author: BenchChem Technical Support Team. **Date:** May 2026

Compound of Interest

Compound Name: 3,3-Difluoroazepane; oxalic acid

Cat. No.: B15303116

[Get Quote](#)

Subject: Advanced Purification Protocols for Fluorinated Azepane Intermediates Ticket ID: FA-PUR-992 Assigned Specialist: Senior Application Scientist, Separation Sciences Division

Introduction: The Fluorine Factor

Welcome to the technical support hub for fluorinated N-heterocycles. You are likely here because standard purification protocols for azepanes (seven-membered amine rings) are failing after the introduction of fluorine atoms.

The Core Problem: Fluorine is not merely a "hydrogen replacement"; it is a high-electronegativity stereoelectronic editor. In azepanes, it fundamentally alters:

- Basicity (): Drastic reductions in amine basicity render standard acid-base extractions inefficient.
- Lipophilicity (): "Fluorophilicity" often causes co-elution with non-fluorinated precursors on C18 silica.
- Stability:

-fluoroamines are prone to spontaneous HF elimination (dehydrofluorination) under thermodynamic stress.

This guide replaces generic "trial-and-error" with protocols based on the specific physical organic chemistry of the C-F bond.

Module 1: The "Invisible" Peak (Detection Strategy)

Symptom: Your LC-MS shows the mass, but the UV trace (254 nm) is flat. You cannot fractionate what you cannot see.

Root Cause Analysis

Saturated azepanes lack chromophores. While a benzyl protecting group might provide UV activity, the fluorine atom itself does not. Furthermore, the C-F bond is "hard" and does not ionize easily in ESI+ unless the amine nitrogen is accessible.

Protocol A: The "Blind" Fractionation (Derivatization)

Do not rely on universal detectors (ELSD/CAD) alone for complex mixtures; they lack structural specificity.

Step-by-Step Workflow:

- Aliquot: Take 10

L of your crude reaction mixture.

- Derivatize: Add 10

L of Fmoc-Cl (fluorenylmethyloxycarbonyl chloride) solution (0.1 M in MeCN).

- Buffer: Add 10

L of sat.

. Shake for 5 minutes.

- Analyze: Run HPLC-UV. The Fmoc group provides a strong chromophore (

265 nm).

- Correlate: Match the retention time of the Fmoc-derivative to your crude ELSD trace to identify the product peak.

Protocol B: NMR Monitoring

The gold standard for fluorinated intermediates.

- Setup: Use a coaxial insert with a known fluorinated standard (e.g.,
-trifluorotoluene,
-63 ppm) in the outer tube.
- Execution: Run the crude mixture. Integrate your product peak against the internal standard.
- Why? This quantifies yield before you lose material on a column.

Module 2: The Basicity Paradox (Extraction Failures)

Symptom: You performed a standard acid/base extraction (1N HCl wash

pH 12 adjustment

DCM extract), but the aqueous phase still contains your product.

The Science: Inductive pKa Depression

Fluorine is the most electronegative element. Through the inductive effect (-I), it pulls electron density away from the nitrogen lone pair, stabilizing the free base and destabilizing the protonated ammonium species.

- Standard Azepane

: ~10.5 - 11.0

- -Fluoroazepane

: ~9.2 - 9.8

- -Fluoroazepane
: ~8.0 - 8.7 (Critical Shift)
- -Difluoroazepane
: ~6.5 - 7.3[1]

The Failure Mode: At pH 10, a standard azepane is fully deprotonated (organic soluble). A

-difluoroazepane might still be 50% protonated (water soluble) if the pH isn't high enough, or conversely, it may not protonate fully in weak acid washes.

Visualization: The "Sliding pH" Extraction Logic

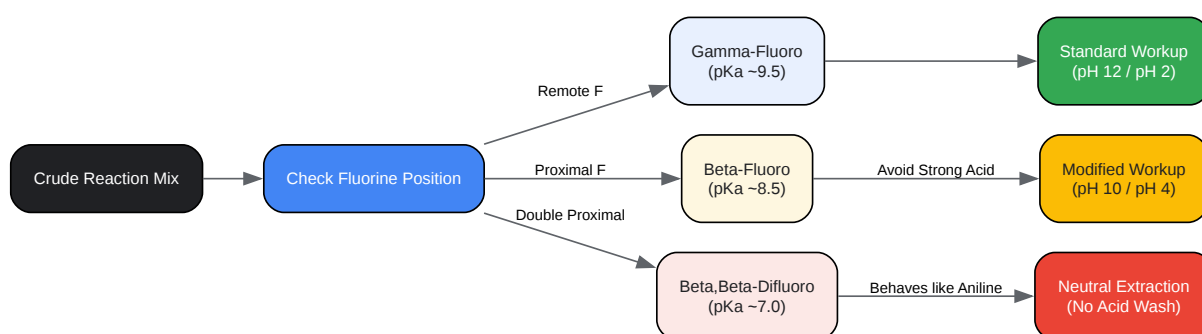

[Click to download full resolution via product page](#)

Figure 1: Decision matrix for workup conditions based on fluorine proximity to the nitrogen center.

Corrective Protocol: The "Salting Out" Extraction

For

-fluoroazepanes where pH manipulation is risky:

- Dilute reaction mixture with EtOAc (avoid DCM if amine is volatile).

- Wash with pH 5.5 Phosphate Buffer (not 1N HCl). The reduced basicity means it will still protonate at pH 5.5, while non-basic impurities stay in EtOAc.
- Basify the aqueous layer to pH 9.0 (using sat. Na_2CO_3). Do not use NaOH (risk of HF elimination).
- Saturate aqueous layer with NaCl (Solid). This is critical. The fluorinated amine is more polar; salting out forces it into the organic phase.
- Extract 3x with CHCl_3 :IPA (3:1). The alcohol helps extract the polar fluorinated amine.

Module 3: Structural Integrity (Dehydrofluorination)

Symptom: Your NMR shows a new alkene peak, and the fluorine signal has disappeared or shifted to -120 ppm (fluoride ion).

Mechanism: E1cB Elimination

In

-fluoroazepanes, the C-H bond

to the nitrogen is acidified by the fluorine. If you use a strong base (NaOH) or heat the compound on silica (which is slightly acidic), you trigger HF elimination, forming an enamine or imine.

Risk Factors:

- Heating > 40°C.
- Strong bases (NaOH , K_2CO_3 , tBuOK , etc.).
- Acidic Silica Gel (Lewis acid sites catalyze HF loss).

Troubleshooting Table: Stability Fixes

| Process Step | Standard Protocol | Fluorinated Azepane Protocol | Why? |
|------------------|-------------------|-------------------------------------|---|
| Concentration | Rotovap at 50°C | Rotovap at < 30°C | Heat promotes thermodynamic elimination of HF. |
| Column Additive | 1% TEA or | 0.5% TEA (Pre-buffered) | Silica acidity catalyzes decomposition; TEA neutralizes it. |
| Stationary Phase | Standard Silica | Basic Alumina or Diol-Bonded Silica | Alumina is non-acidic; Diol phases reduce silanol interactions. |
| Salt Formation | HCl gas in Ether | Oxalic Acid or Fumaric Acid | HCl is too strong and hygroscopic; weaker acids form stable, non-hygroscopic salts. |

Module 4: Chromatographic Separation

Symptom: The fluorinated azepane co-elutes with the non-fluorinated impurity or regioisomers.

The "Fluorophilic" Effect

On standard C18, one fluorine atom often mimics hydrogen, offering poor selectivity. However, fluorine has a unique "fluorophilic" interaction.

Protocol: Fluorous Phase Separation

If C18 fails, switch to a Pentafluorophenyl (PFP) or Fluoro-alkyl (HFD) stationary phase.

Separation Logic:

- Mechanism:

interactions (PFP) and dipole-dipole interactions specific to the C-F bond.

- Mobile Phase: Water/Methanol gradients.[2] (Avoid Acetonitrile if possible; MeOH enhances the "fluorine effect").
- Result: Fluorinated compounds typically retain longer on PFP columns than their non-fluorinated analogs, whereas they might elute faster on C18 due to polarity.

Workflow Visualization: Purification Decision Tree

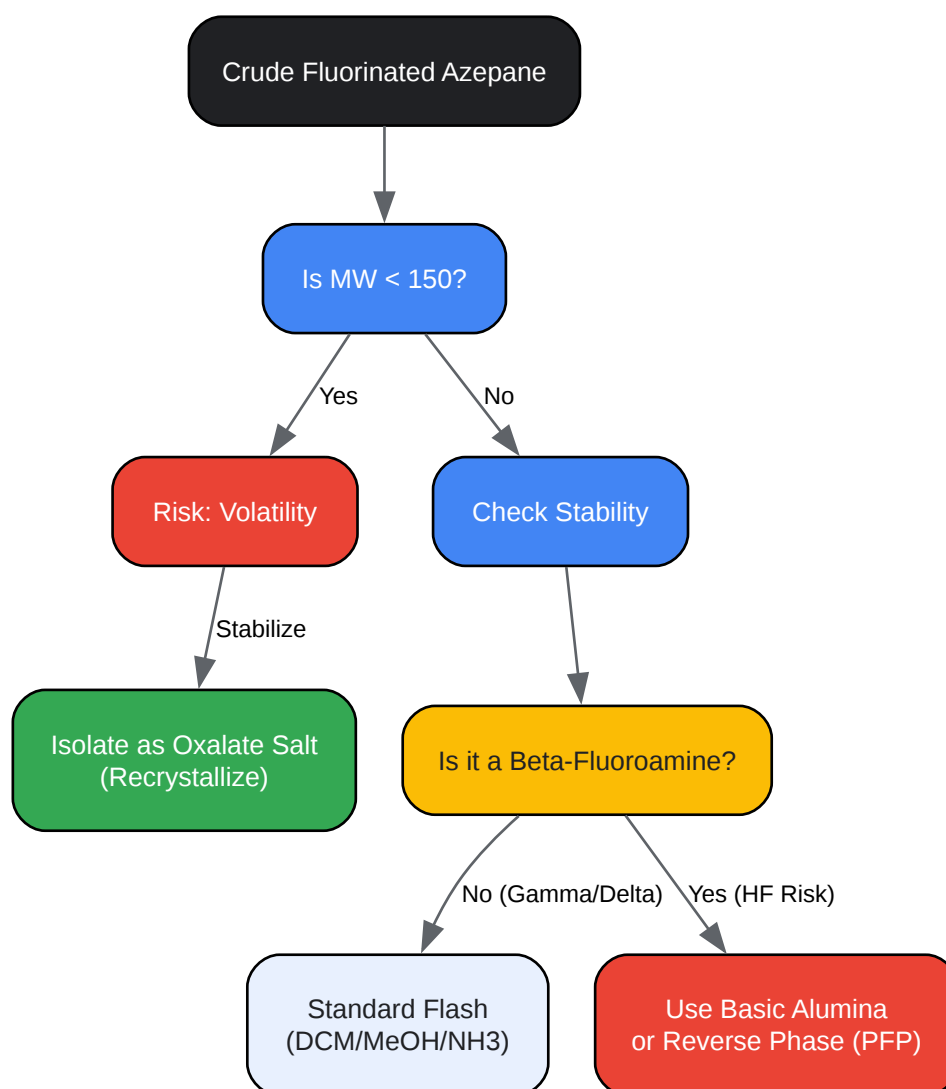

[Click to download full resolution via product page](#)

Figure 2: Selection guide for purification method based on molecular weight and fluorine position.

Frequently Asked Questions (FAQ)

Q: My

-fluoroazepane decomposes on the silica column even with TEA. What now? A: Switch to Reverse Phase (C18 or PFP) at neutral pH. Use Ammonium Bicarbonate (10mM, pH 7.4) as the aqueous buffer. Avoid TFA (Trifluoroacetic acid) as it is strong enough to induce elimination during concentration.

Q: Can I distill fluorinated azepanes? A: Only if the fluorine is at the

or

position.

-fluoroazepanes are thermally unstable and will likely eliminate HF at the temperatures required for distillation. Kugelrohr distillation at high vacuum/low temp is the only safe thermal method.

Q: How do I separate the cis/trans stereoisomers of 3-fluoro-4-methylazepane? A: These are notoriously difficult. Standard silica won't work. Use Supercritical Fluid Chromatography (SFC) with a 2-Ethylpyridine or Diol column. The orthogonal selectivity of SFC is often required for fluorinated diastereomers.

References

- Purification and pKa of Fluorinated Amines Morgenthaler, M., et al. "Predicting and Tuning Physicochemical Properties in Lead Optimization: Amine Basicities." ChemMedChem, 2007.
- Synthesis and Stability of
-Fluoroamines Kalow, J. A., & Doyle, A. G.[3] "Synthesis of
-Fluoroamines by Lewis Base Catalyzed Hydrofluorination of Aziridines." [3] Journal of Organic Chemistry, 2012.[3]
- Fluorine in Medicinal Chemistry (General Principles) Purser, S., et al. "Fluorine in medicinal chemistry." [3][4][5] Chemical Society Reviews, 2008.
- Chromatographic Separation of Fluorinated Compounds O'Hagan, D.[2] "Understanding organofluorine chemistry. An introduction to the C–F bond." Chemical Society Reviews,

2008.

- Detection of Non-UV Active Compounds Linclau, B., et al.[6] "Investigating the Influence of (Deoxy)fluorination on the Lipophilicity of Non-UV-Active Fluorinated Alkanols." *Angewandte Chemie*, 2016.[6]

Need Custom Synthesis?

BenchChem offers custom synthesis for rare earth carbides and specific isotopic labeling.

Email: info@benchchem.com or [Request Quote Online](#).

Sources

- 1. [mdpi.com](https://www.mdpi.com) [[mdpi.com](https://www.mdpi.com)]
- 2. academic.oup.com [academic.oup.com]
- 3. Synthesis of β -Fluoroamines by Lewis Base Catalyzed Hydrofluorination of Aziridines [[organic-chemistry.org](https://www.organic-chemistry.org)]
- 4. Fluorination methods for drug discovery and development - PubMed [pubmed.ncbi.nlm.nih.gov]
- 5. [researchgate.net](https://www.researchgate.net) [[researchgate.net](https://www.researchgate.net)]
- 6. Investigating the Influence of (Deoxy)fluorination on the Lipophilicity of Non-UV-Active Fluorinated Alkanols and Carbohydrates by a New log P Determination Method - PubMed [pubmed.ncbi.nlm.nih.gov]
- To cite this document: BenchChem. [Technical Support Center: Fluorinated Azepane Purification]. BenchChem, [2026]. [Online PDF]. Available at: [<https://www.benchchem.com/product/b15303116/docs#technical-support-center-fluorinated-azepane-purification>]

Disclaimer & Data Validity:

The information provided in this document is for Research Use Only (RUO) and is strictly not intended for diagnostic or therapeutic procedures. While BenchChem strives to provide accurate protocols, we make no warranties, express or implied, regarding the fitness of this product for every specific experimental setup.

Technical Support: The protocols provided are for reference purposes. Unsure if this reagent suits your experiment?

Need Industrial/Bulk Grade? [Request Custom Synthesis Quote](#)

BenchChem

Our mission is to be the trusted global source of essential and advanced chemicals, empowering scientists and researchers to drive progress in science and industry.

Contact

Address: 3281 E Guasti Rd
Ontario, CA 91761, United States
Phone: (601) 213-4426
Email: info@benchchem.com

[Contact our Ph.D. Support Team for a compatibility check](#)