

antimicrobial activity of acetohydrazide derivatives

Author: BenchChem Technical Support Team. **Date:** May 2026

Compound of Interest

Compound Name: 2-(6-(Trifluoromethyl)pyridin-3-yl)acetohydrazide

CAS No.: 1805762-08-6

Cat. No.: B1530018

[Get Quote](#)

Application Note: Antimicrobial Profiling of Acetohydrazide Derivatives

Abstract

Acetohydrazide derivatives (

) represent a privileged pharmacophore in antimicrobial drug discovery due to their dual ability to form Schiff bases and chelate transition metal ions. This guide outlines a high-fidelity workflow for evaluating the antimicrobial efficacy of these compounds. Unlike standard antibiotic screening, acetohydrazides require specific handling due to solubility constraints and complex mechanisms of action involving DNA gyrase inhibition and membrane depolarization. This document details protocols for rational design, Minimum Inhibitory Concentration (MIC) determination using Resazurin (REMA), and cytotoxicity profiling.

Rational Design & Structure-Activity Relationship (SAR)

To maximize antimicrobial potency, the acetohydrazide scaffold is rarely used in isolation. It serves as a linker or "hinge" connecting two lipophilic domains.

- **Pharmacophore Hybridization:** The most potent derivatives often hybridize the acetohydrazide linker with quinoline, pyrazole, or coumarin moieties. These bulky heterocycles facilitate penetration through the bacterial cell wall.
- **Electronic Effects:** Incorporation of Electron-Withdrawing Groups (EWGs)—specifically Fluorine (-F), Trifluoromethyl (-CF₃), or Nitro (-NO₂)—at the para position of the phenyl ring attached to the hydrazide nitrogen significantly enhances potency. This is attributed to increased lipophilicity and stronger hydrogen bonding interactions with the target enzyme (e.g., DNA Gyrase).
- **Metal Chelation:** The carbonyl oxygen and hydrazidic nitrogen can chelate ions like
or
. While this boosts toxicity against bacteria, it can also increase mammalian cytotoxicity, necessitating rigorous Selectivity Index (SI) testing.

Development Pipeline Visualization

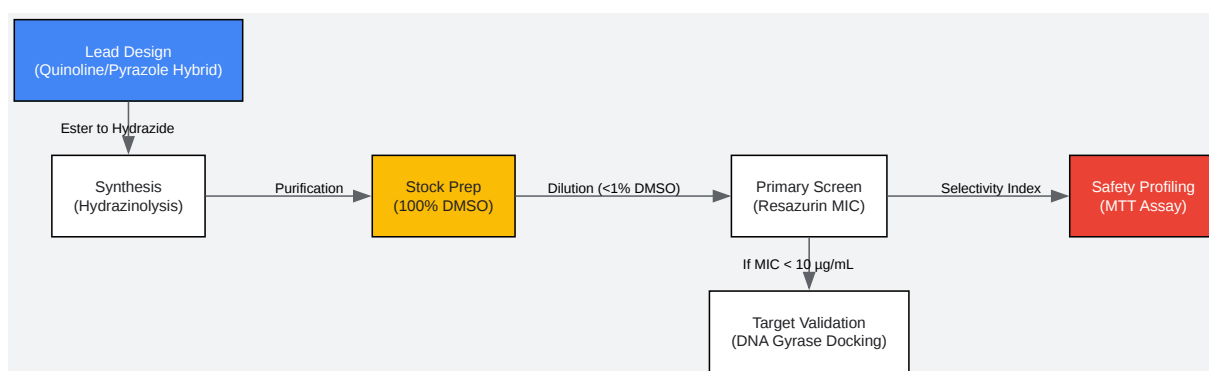

[Click to download full resolution via product page](#)

Figure 1: Integrated workflow for the development and testing of acetohydrazide antimicrobials.

Protocol A: Stock Preparation & Solubility Management

Challenge: Acetohydrazide derivatives are often hydrophobic and prone to precipitation in aqueous Muller-Hinton Broth (MHB), leading to false "turbidity" readings in standard optical density assays.

Procedure:

- **Solvent Selection:** Dissolve the solid compound in 100% Dimethyl Sulfoxide (DMSO). Do not use ethanol, as it evaporates during incubation, altering concentrations.
- **Concentration:** Prepare a master stock at 10 mg/mL (10,000 µg/mL).
- **Sonication:** Sonicate for 5–10 minutes at 40 kHz to ensure complete dissolution.
- **Working Solution:** Dilute the master stock 1:10 in sterile MHB to achieve a starting concentration of 1,000 µg/mL.
 - **Critical Check:** The final DMSO concentration in the first well of the assay plate must be to avoid solvent toxicity masking the compound's activity.

Protocol B: Resazurin Microtiter Assay (REMA)

Rationale: Standard turbidity (OD₆₀₀) measurements are unreliable for acetohydrazides due to micro-precipitation. The REMA method uses a metabolic indicator (Resazurin) that turns from blue (oxidized/dead) to pink (reduced/live), providing a clear colorimetric endpoint regardless of compound solubility.

Materials:

- 96-well microplates (U-bottom).
- Muller-Hinton Broth (cation-adjusted).

- Resazurin sodium salt (0.015% w/v in PBS).
- Test strains: *S. aureus* (ATCC 29213), *E. coli* (ATCC 25922).

Step-by-Step Methodology:

- Inoculum Prep: Adjust bacterial culture to 0.5 McFarland standard (CFU/mL), then dilute 1:100 in MHB.
- Serial Dilution:
 - Add 100 μ L of MHB to columns 2–12.
 - Add 200 μ L of compound working solution (from Protocol A) to column 1.
 - Transfer 100 μ L from col 1 to col 2, mix, and repeat across to col 10. Discard the final 100 μ L.
 - Columns 11 & 12: Growth Control (bacteria + solvent) and Sterility Control (media only).
- Inoculation: Add 100 μ L of the diluted bacterial suspension to wells 1–11. Final volume = 200 μ L.
- Incubation: Incubate at 37°C for 18–24 hours.
- Visualization: Add 30 μ L of Resazurin solution to each well. Incubate for an additional 2–4 hours.
- Readout:
 - Blue: No growth (Inhibition).
 - Pink: Growth.
 - MIC Definition: The lowest concentration that remains blue (prevents color change).

Data Reporting Template:

Compound ID	R-Group	S. aureus MIC (µg/mL)	E. coli MIC (µg/mL)	Interpretation
AHZ-01	-H	64	>128	Inactive
AHZ-04	-NO2	4	16	Potent
Ciprofloxacin	(Ref)	0.5	0.015	Control

Protocol C: Mechanism of Action (DNA Gyrase Targeting)

Many acetohydrazide derivatives, particularly quinoline-hybrids, function by inhibiting bacterial DNA Gyrase (GyrB subunit), preventing ATP hydrolysis and supercoiling.

In Silico Validation (Molecular Docking): Before expensive enzymatic assays, validate the binding potential.

- Target Retrieval: Download Crystal Structure of DNA Gyrase B (e.g., PDB ID: 2ZJT for S. aureus or 1ZI0 for E. coli) from the RCSB Protein Data Bank.
- Ligand Prep: Energy minimize the acetohydrazide derivative (MMFF94 force field).
- Docking: Use AutoDock Vina or Glide.
- Success Metric: A binding energy score lower than -7.5 kcal/mol suggests strong affinity. Look for H-bonds between the hydrazide -NH- and the Asp73 residue in the ATP-binding pocket.

Mechanism Pathway Visualization

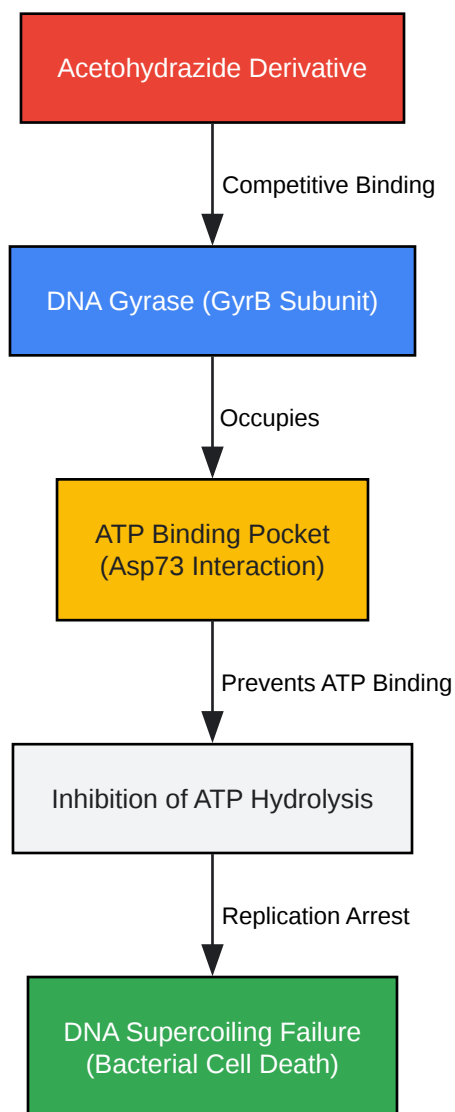

[Click to download full resolution via product page](#)

Figure 2: Mechanism of Action: Competitive inhibition of the ATPase domain in DNA Gyrase.

Protocol D: Cytotoxicity & Selectivity Index (SI)

To ensure the compound is an antibiotic and not a general poison, the Selectivity Index (SI) must be calculated:

. An SI > 10 is the industry threshold for a promising lead.

Method: MTT Assay on Vero or HEK293 Cells

- Seeding: Seed cells at

cells/well in 96-well plates. Incubate 24h for attachment.

- Treatment: Treat cells with serial dilutions of the acetohydrazide derivative (using the same stock from Protocol A).
- Incubation: Incubate for 48 hours at 37°C, 5% CO₂.
- MTT Addition: Add MTT reagent (5 mg/mL). Incubate 4 hours.
- Solubilization: Discard supernatant. Add 100 µL DMSO to dissolve purple formazan crystals.
- Calculation: Measure OD570. Calculate
(concentration causing 50% cell death).

References

- Sridhara, P., et al. (2016).[1] Synthesis of quinoline acetohydrazide-hydrazone derivatives evaluated as DNA gyrase inhibitors and potent antimicrobial agents.[1][2][3] RSC Advances. [Link](#)
- Clinical and Laboratory Standards Institute (CLSI). (2018). M07: Methods for Dilution Antimicrobial Susceptibility Tests for Bacteria That Grow Aerobically. [Link](#)
- Gouda, M.A., et al. (2020).[2] Synthesis and antimicrobial evaluation of some new acetohydrazide derivatives. Journal of Basic and Applied Sciences. [Link](#)
- Riss, T.L., et al. (2016). Cell Viability Assays: The MTT Assay.[4][5][6] Assay Guidance Manual (NCBI). [Link](#)
- Kataria, R., et al. (2019). Novel Acetohydrazide Pyrazole Derivatives: Design, Synthesis, Characterization and Antimicrobial Activity. Asian Journal of Chemistry. [Link](#)

Need Custom Synthesis?

BenchChem offers custom synthesis for rare earth carbides and specific isotopic labeling.

Email: info@benchchem.com or [Request Quote Online](#).

Sources

- 1. Synthesis of quinoline acetohydrazide-hydrazone derivatives evaluated as DNA gyrase inhibitors and potent antimicrobial agents - RSC Advances (RSC Publishing) [pubs.rsc.org]
- 2. [rsc.org](https://www.rsc.org) [[rsc.org](https://www.rsc.org)]
- 3. Synthesis of quinoline acetohydrazide-hydrazone derivatives evaluated as DNA gyrase inhibitors and potent antimicrobial agents - RSC Advances (RSC Publishing) [pubs.rsc.org]
- 4. The MTT Assay: Utility, Limitations, Pitfalls, and Interpretation in Bulk and Single-Cell Analysis | MDPI [[mdpi.com](https://www.mdpi.com)]
- 5. Cytotoxicity MTT Assay Protocols and Methods | Springer Nature Experiments [experiments.springernature.com]
- 6. Cell sensitivity assays: the MTT assay - PubMed [pubmed.ncbi.nlm.nih.gov]
- To cite this document: BenchChem. [antimicrobial activity of acetohydrazide derivatives]. BenchChem, [2026]. [Online PDF]. Available at: [<https://www.benchchem.com/product/b1530018/docs#antimicrobial-activity-of-acetohydrazide-derivatives>]

Disclaimer & Data Validity:

The information provided in this document is for Research Use Only (RUO) and is strictly not intended for diagnostic or therapeutic procedures. While BenchChem strives to provide accurate protocols, we make no warranties, express or implied, regarding the fitness of this product for every specific experimental setup.

Technical Support: The protocols provided are for reference purposes. Unsure if this reagent suits your experiment?

Need Industrial/Bulk Grade? [Request Custom Synthesis Quote](#)

BenchChem

Our mission is to be the trusted global source of essential and advanced chemicals, empowering scientists and researchers to drive progress in science and industry.

Contact

Address: 3281 E Guasti Rd

Ontario, CA 91761, United States

Phone: (601) 213-4426

Email: info@benchchem.com

[Contact our Ph.D. Support Team for a compatibility check](#)