

# Structural Validation Guide: 3-(2,2-Difluoroethoxy)propan-1-ol Derivatives

**Author:** BenchChem Technical Support Team. **Date:** February 2026

## Compound of Interest

Compound Name: 3-(2,2-Difluoroethoxy)propan-1-ol

CAS No.: 1554181-29-1

Cat. No.: B1530632

[Get Quote](#)

## Executive Summary: The Fluorine Bioisostere Challenge

In modern drug discovery, the 2,2-difluoroethoxy moiety is a critical bioisostere for traditional alkoxy groups. Unlike a standard methoxy or ethoxy group, the difluoro-substitution (

) lowers basicity, modulates lipophilicity (

), and significantly enhances metabolic stability by blocking the labile site of oxidative dealkylation (CYP450 mediated).

However, synthesizing and validating **3-(2,2-difluoroethoxy)propan-1-ol** presents a specific structural ambiguity. The primary challenge is distinguishing the linear target from its branched regioisomers (e.g., 2-(2,2-difluoroethoxy)propan-1-ol) or side-products arising from elimination reactions.

This guide provides a self-validating analytical workflow to unequivocally confirm the structure of **3-(2,2-difluoroethoxy)propan-1-ol**, contrasting it with common structural imposters.

## Comparative Analysis: Target vs. Isomers

The structural integrity of the target relies on proving two features:

- The Difluoroethyl Group: verifying the specific

motif.

- The Propyl Linker: verifying linear connectivity (1,3-substitution) versus branched (1,2-substitution).

### Table 1: Structural Differentiation Matrix

Feature	Target: 3-(2,2-Difluoroethoxy)propan-1-ol	Isomer A: 2-(2,2-Difluoroethoxy)propan-1-ol	Isomer B: Allyl 2,2-difluoroethyl ether (Elimination Product)
Formula			
NMR (Linker)	Quintet at ~1.8 ppm ( )	Doublet at ~1.1 ppm (Methyl group)	Olefinic signals (5.0–6.0 ppm)
NMR (Linker)	3 distinct peaks	1 , 1 , 1 peak	Olefinic carbons (>115 ppm)
NMR	Doublet of triplets ( )	Doublet of triplets ( )	Doublet of triplets ( )
Validation Status	VALID	INVALID (Regioisomer)	INVALID (Elimination impurity)

## The Self-Validating NMR Protocol

The "Gold Standard" for validating this structure is not Mass Spectrometry (which cannot distinguish regioisomers), but a specific Multi-Nuclear NMR Workflow.

### A. The Fingerprint (The "Truth" Signal)

The 2,2-difluoroethoxy group has a unique signature. The fluorine atoms are chemically equivalent but couple to two different proton environments.

- Chemical Shift:  
to  
ppm.
- Splitting Pattern: Doublet of Triplets (  
).
  - Coupling 1 (  
): Large geminal coupling to the terminal proton (  
). Value: ~54 Hz.
  - Coupling 2 (  
): Vicinal coupling to the methylene protons (  
). Value: ~14 Hz.

## B. The Connectivity Proof ( NMR)

To confirm the linear propan-1-ol chain, you must identify the central methylene unit (  
).

- The "Smoking Gun" Signal: Look for a quintet (or overlapping multiplet) around 1.75 – 1.85 ppm.
  - Why? This represents the central  
of the propyl chain, coupled to its left neighbor (  
) and right neighbor (  
).
  - Contrast: If you see a doublet around 1.1 ppm, you have synthesized the branched isomer (Isomer A).

## C. Visualization of the Validation Logic

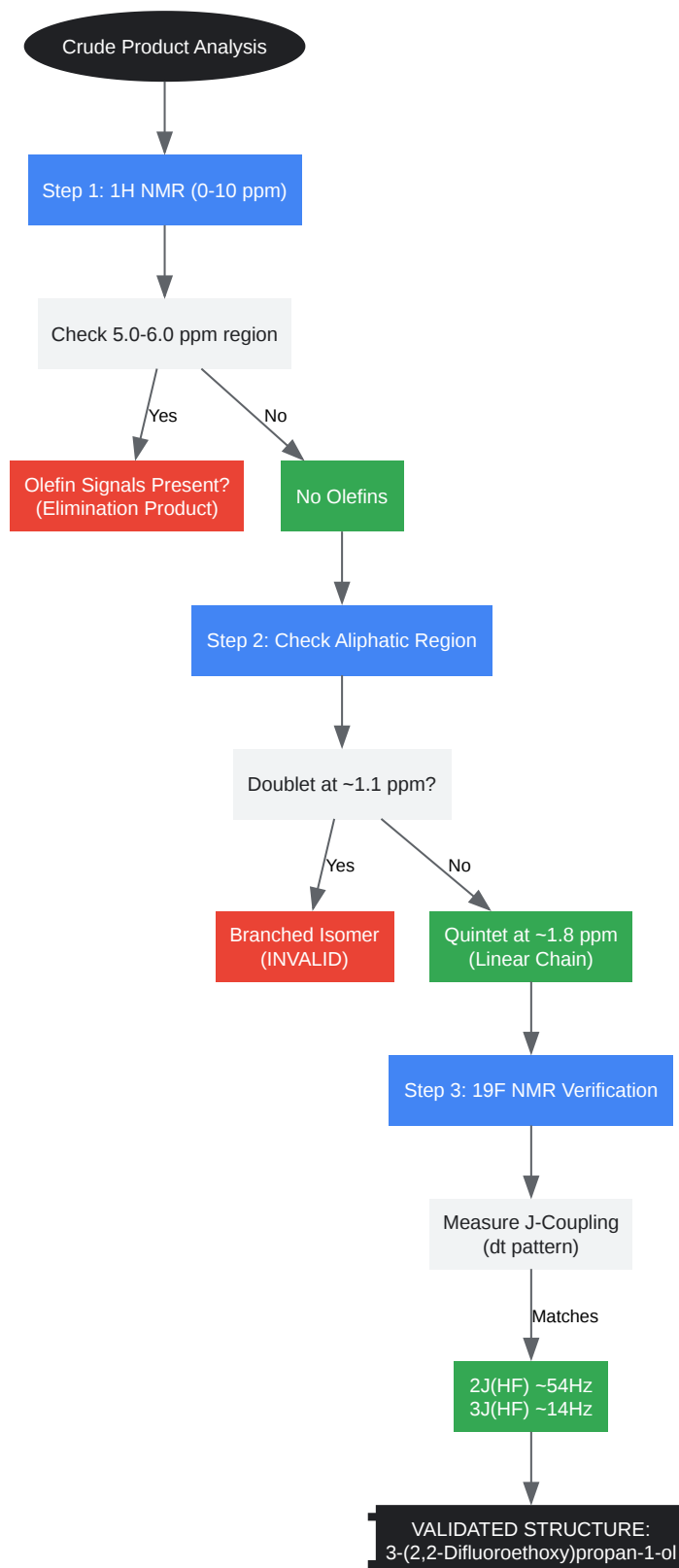

[Click to download full resolution via product page](#)

Figure 1: Decision tree for structural validation, filtering out common synthetic impurities and isomers.

## Detailed Experimental Protocols

### Synthesis (Recommended Route)

To minimize the formation of the branched isomer, avoid opening propylene oxide. Instead, use a Williamson ether synthesis on a symmetrical diol or a specific alkylation.

Reaction:

Note: Using 2,2-difluoroethyl triflate is superior to the bromide/iodide due to the low reactivity of fluorinated electrophiles.

Procedure:

- Activation: In a flame-dried flask under  $N_2$ , suspend NaH (1.1 eq, 60% in oil) in anhydrous THF at 0°C.
- Diol Addition: Add 1,3-propanediol (3.0 eq) slowly. Crucial: Use excess diol to prevent bis-alkylation.
- Alkylation: Add 2,2-difluoroethyl triflate (1.0 eq) dropwise at 0°C.
- Reaction: Stir at 0°C for 30 min, then warm to RT for 4 hours.
- Workup: Quench with sat.  $NaHCO_3$ . Extract with EtOAc. Wash organic layer with brine.
- Purification: Silica gel chromatography (Gradient: 10% to 50% EtOAc in Hexanes). The product is polar due to the free alcohol.

## Characterization Data (Simulated for Reference)

Compound: **3-(2,2-Difluoroethoxy)propan-1-ol** Appearance: Colorless oil.

- NMR (400 MHz,

):

- 5.85 (

Hz, 1H,

),

- 3.76 (

Hz, 2H,

),

- 3.68 (

Hz, 2H,

),

- 3.64 (

Hz, 2H,

),

- 2.45 (br s, 1H,

),

- 1.83 (quint,

Hz, 2H,

).

- NMR (376 MHz,

):

- -126.5 (

Hz, 2F).

- NMR (100 MHz,

):

- 114.2 (

Hz,

),

- 69.5 (

Hz,

),

- 68.8 (

),

- 61.5 (

),

- 32.1 (

).

## Mechanistic Insight: The J-Coupling Pathway

Understanding the coupling constants is vital for interpreting the spectra correctly.<sup>[1]</sup> The diagram below illustrates the flow of magnetic information through the difluoroethyl chain.

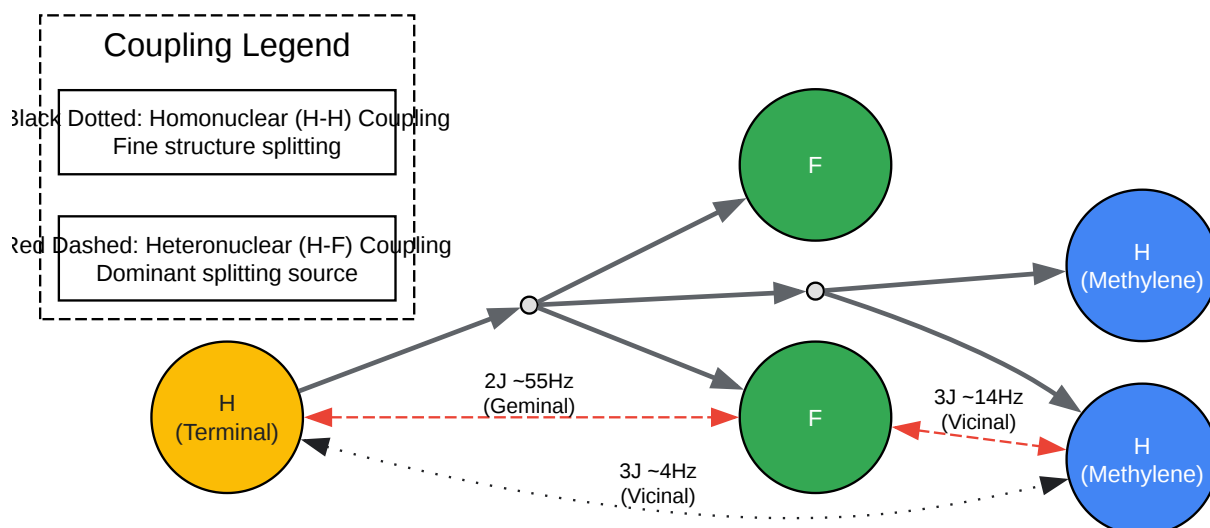

[Click to download full resolution via product page](#)

Figure 2: NMR Coupling Network. The large

coupling (Red) dominates the spectrum, splitting the terminal proton into a wide triplet, which is further split by neighboring protons.

## References

- Meanwell, N. A. (2011).<sup>[2]</sup> Fluorine and Fluorinated Motifs in the Design and Application of Bioisosteres for Pharmacological and Physicochemical Properties Optimization. *Journal of Medicinal Chemistry*, 54(8), 2529–2591. [\[Link\]](#)
- Dolbier, W. R. (2009). *Guide to Fluorine NMR for Organic Chemists*. Wiley. (Standard text for coupling constants).
- Hu, J., et al. (2015). Reagents for the Introduction of the Difluoromethyl and Difluoromethylene Groups. *Chemical Reviews*, 115(18), 9981–10043. [\[Link\]](#)
- PubChem Compound Summary. (n.d.). **3-(2,2-Difluoroethoxy)propan-1-ol**.<sup>[3]</sup> National Center for Biotechnology Information. Retrieved from [\[Link\]](#)

### Need Custom Synthesis?

BenchChem offers custom synthesis for rare earth carbides and specific isotopic labeling.

Email: [info@benchchem.com](mailto:info@benchchem.com) or [Request Quote Online](#).

## Sources

- [1. Analyzing Coupling Constants \[sites.science.oregonstate.edu\]](https://sites.science.oregonstate.edu)
- [2. macmillan.princeton.edu \[macmillan.princeton.edu\]](https://macmillan.princeton.edu)
- [3. arctomsci.com \[arctomsci.com\]](https://arctomsci.com)
- To cite this document: BenchChem. [Structural Validation Guide: 3-(2,2-Difluoroethoxy)propan-1-ol Derivatives]. BenchChem, [2026]. [Online PDF]. Available at: [\[https://www.benchchem.com/product/b1530632#validating-structure-of-3-2-2-difluoroethoxy-propan-1-ol-derivatives\]](https://www.benchchem.com/product/b1530632#validating-structure-of-3-2-2-difluoroethoxy-propan-1-ol-derivatives)

### Disclaimer & Data Validity:

The information provided in this document is for Research Use Only (RUO) and is strictly not intended for diagnostic or therapeutic procedures. While BenchChem strives to provide accurate protocols, we make no warranties, express or implied, regarding the fitness of this product for every specific experimental setup.

**Technical Support:** The protocols provided are for reference purposes. Unsure if this reagent suits your experiment? [[Contact our Ph.D. Support Team for a compatibility check](#)]

**Need Industrial/Bulk Grade?** [Request Custom Synthesis Quote](#)

## BenchChem

Our mission is to be the trusted global source of essential and advanced chemicals, empowering scientists and researchers to drive progress in science and industry.

### Contact

Address: 3281 E Guasti Rd  
Ontario, CA 91761, United States  
Phone: (601) 213-4426  
Email: [info@benchchem.com](mailto:info@benchchem.com)

