

# Application Note: Elucidating the Mass Spectrometry Fragmentation Pattern of 4-Methoxy-3-oxopentanenitrile

**Author:** BenchChem Technical Support Team. **Date:** May 2026

## Compound of Interest

Compound Name: 4-Methoxy-3-oxopentanenitrile

CAS No.: 1028843-13-1

Cat. No.: B1530771

[Get Quote](#)

## Abstract

This application note provides a detailed analysis of the predicted electron ionization (EI) mass spectrometry fragmentation pattern of **4-methoxy-3-oxopentanenitrile**. In the absence of a publicly available experimental spectrum for this specific compound, this guide synthesizes established principles of mass spectrometry to forecast the primary fragmentation pathways. Understanding these patterns is crucial for the structural elucidation and identification of this and related  $\beta$ -keto nitriles in complex matrices within drug discovery, metabolomics, and synthetic chemistry. A comprehensive protocol for acquiring a mass spectrum of **4-methoxy-3-oxopentanenitrile** using a gas chromatography-mass spectrometry (GC-MS) system is also presented.

## Introduction

**4-Methoxy-3-oxopentanenitrile**, with a molecular formula of  $C_6H_9NO_2$  and a molecular weight of 127.14 g/mol, is a multifunctional compound containing a methoxy group, a ketone, and a nitrile. The interplay of these functional groups under electron ionization leads to a

characteristic fragmentation pattern that can serve as a molecular fingerprint for its identification. Mass spectrometry, particularly when coupled with gas chromatography, is a powerful technique for the analysis of such volatile and semi-volatile organic compounds. This document serves as a guide for researchers to understand and predict the fragmentation behavior of **4-methoxy-3-oxopentanenitrile**, aiding in its unambiguous identification.

## Predicted Fragmentation Pathways

Upon electron ionization, **4-methoxy-3-oxopentanenitrile** will form a molecular ion ( $[M]^+$ ) at  $m/z$  127. The subsequent fragmentation is predicted to be dominated by cleavages alpha to the carbonyl group and the methoxy group, as these are energetically favorable processes.

The primary fragmentation pathways are expected to be:

- $\alpha$ -Cleavage adjacent to the carbonyl group: This is a hallmark of ketone fragmentation and is expected to be a major pathway. This can occur on either side of the carbonyl.
  - Loss of the cyanomethyl radical ( $\bullet\text{CH}_2\text{CN}$ ): This cleavage results in the formation of a stable acylium ion at  $m/z$  87. This is predicted to be a prominent peak in the spectrum.
  - Loss of the methoxyethyl radical ( $\bullet\text{CH}_2\text{CH}_2\text{OCH}_3$ ): This cleavage would lead to a fragment at  $m/z$  57. However, cleavage of the stronger C-C bond is generally more favorable.
- Cleavage involving the methoxy group: Ethers are known to undergo  $\alpha$ -cleavage.<sup>[1][2][3]</sup>
  - Loss of a methyl radical ( $\bullet\text{CH}_3$ ): Cleavage of the C-O bond in the methoxy group or the C-C bond alpha to the oxygen can result in the loss of a methyl radical, leading to a fragment at  $m/z$  112.
  - Loss of a methoxy radical ( $\bullet\text{OCH}_3$ ): This would result in a fragment at  $m/z$  96.
- McLafferty Rearrangement: For aliphatic ketones and nitriles with a  $\gamma$ -hydrogen, a McLafferty rearrangement is a common fragmentation pathway.<sup>[4][5]</sup> In **4-methoxy-3-oxopentanenitrile**, the presence of  $\gamma$ -hydrogens allows for this rearrangement, which would involve the transfer of a hydrogen atom to the carbonyl oxygen followed by  $\beta$ -cleavage, leading to the expulsion of a neutral alkene and the formation of a characteristic enol radical cation. This could result in a fragment at  $m/z$  71.

- Cleavage involving the nitrile group: Nitriles can undergo loss of HCN (27 Da).[6] The loss of HCN from the molecular ion would produce a fragment at m/z 100.

## Predicted Mass Spectrum Data

The following table summarizes the predicted major fragment ions for **4-methoxy-3-oxopentanenitrile**, their proposed structures, and the fragmentation mechanism.

m/z	Proposed Structure	Fragmentation Pathway	Predicted Relative Abundance
127	$[\text{C}_6\text{H}_9\text{NO}_2]^+$	Molecular Ion	Low to Medium
112	$[\text{C}_5\text{H}_6\text{NO}_2]^+$	Loss of $\bullet\text{CH}_3$	Medium
96	$[\text{C}_5\text{H}_6\text{NO}]^+$	Loss of $\bullet\text{OCH}_3$	Low
87	$[\text{CH}_3\text{OCH}_2\text{CO}]^+$	$\alpha$ -Cleavage (loss of $\bullet\text{CH}_2\text{CN}$ )	High (likely base peak)
71	$[\text{C}_3\text{H}_5\text{NO}]^+$	McLafferty Rearrangement	Medium
57	$[\text{CH}_2\text{CN}]^+$	$\alpha$ -Cleavage	Medium
43	$[\text{CH}_3\text{CO}]^+$	Secondary Fragmentation	Medium
42	$[\text{C}_2\text{H}_4\text{N}]^+$	Rearrangement and cleavage	Medium

## Visualization of Fragmentation Pathways

The predicted fragmentation pathways can be visualized using the following diagrams:

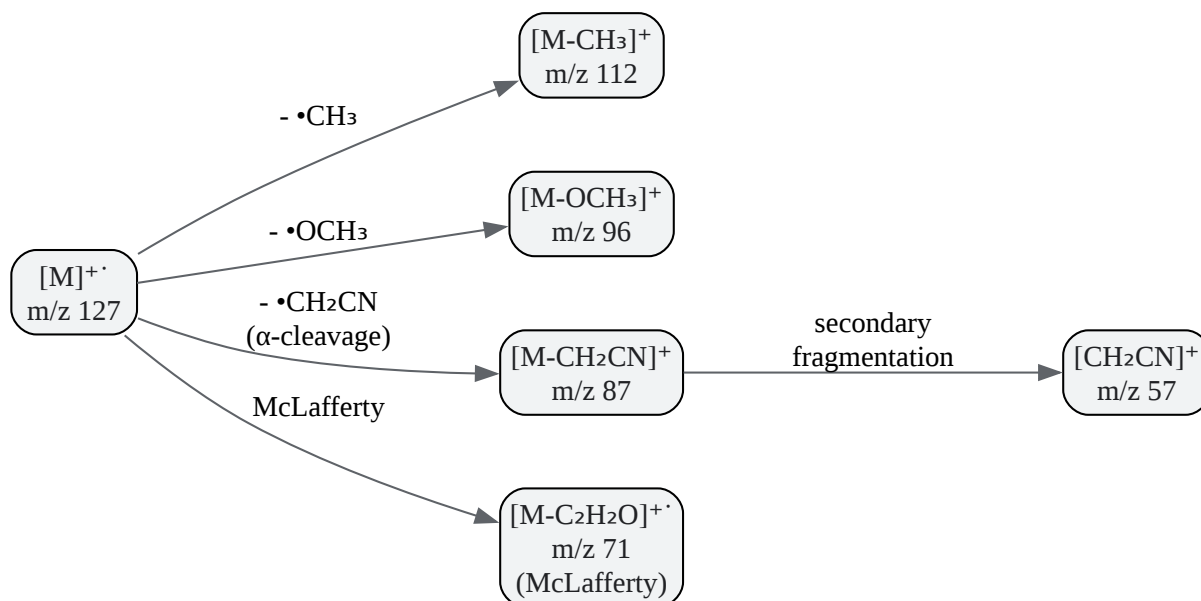

[Click to download full resolution via product page](#)

Caption: Predicted major fragmentation pathways of **4-methoxy-3-oxopentanenitrile**.

## Experimental Protocol for GC-MS Analysis

This protocol provides a general framework for the analysis of **4-methoxy-3-oxopentanenitrile** using a standard GC-MS system. Optimization may be required based on the specific instrumentation used.

### 5.1. Sample Preparation

- **Standard Solution:** Prepare a 1 mg/mL stock solution of **4-methoxy-3-oxopentanenitrile** in a high-purity solvent such as ethyl acetate or dichloromethane.
- **Working Solution:** Dilute the stock solution to a final concentration of 10-100  $\mu\text{g/mL}$  in the same solvent.

### 5.2. GC-MS Instrumentation and Parameters

- Gas Chromatograph: Agilent 8890 GC System (or equivalent)
- Mass Spectrometer: Agilent 5977B GC/MSD (or equivalent)
- GC Column: HP-5ms (30 m x 0.25 mm, 0.25  $\mu$ m film thickness) or equivalent non-polar column.
- Injector:
  - Inlet Temperature: 250 °C
  - Injection Volume: 1  $\mu$ L
  - Split Ratio: 20:1
- Oven Program:
  - Initial Temperature: 60 °C, hold for 2 minutes
  - Ramp: 10 °C/min to 280 °C
  - Final Hold: 5 minutes at 280 °C
- Carrier Gas: Helium at a constant flow of 1.2 mL/min.
- Mass Spectrometer Parameters:
  - Ion Source: Electron Ionization (EI)
  - Ionization Energy: 70 eV
  - Source Temperature: 230 °C
  - Quadrupole Temperature: 150 °C
  - Scan Range: m/z 35-300

### 5.3. Data Analysis

- Acquire the total ion chromatogram (TIC) to determine the retention time of the analyte.
- Extract the mass spectrum from the apex of the chromatographic peak corresponding to **4-methoxy-3-oxopentanenitrile**.
- Identify the molecular ion peak and major fragment ions.
- Compare the experimental fragmentation pattern with the predicted pattern and with library spectra (if available) for confirmation.

## Experimental Workflow Diagram

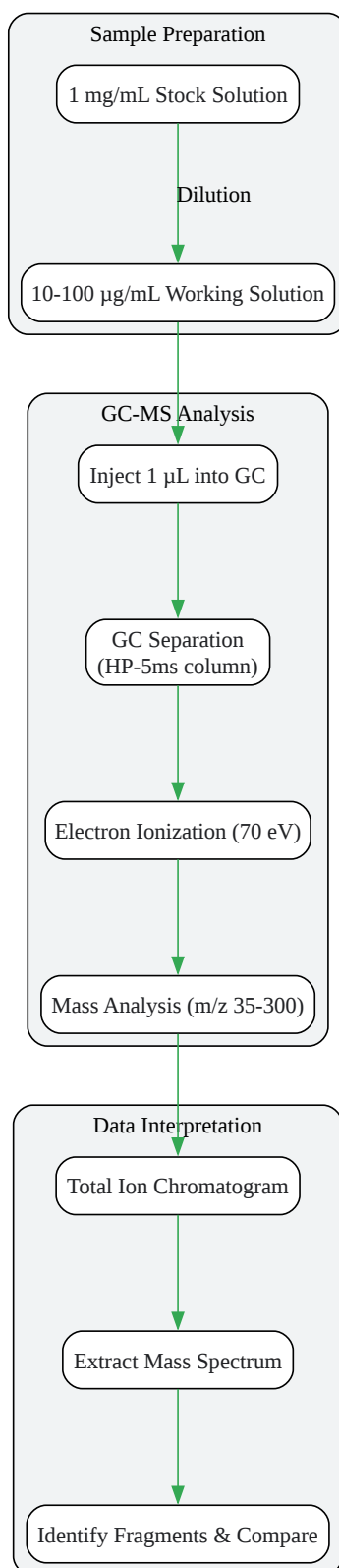

[Click to download full resolution via product page](#)

Caption: Workflow for the GC-MS analysis of **4-methoxy-3-oxopentanenitrile**.

## Conclusion

This application note presents a detailed, albeit predictive, analysis of the mass spectrometry fragmentation pattern of **4-methoxy-3-oxopentanenitrile**. The proposed fragmentation pathways, dominated by  $\alpha$ -cleavage and potential McLafferty rearrangement, provide a robust framework for the identification of this compound in experimental settings. The provided GC-MS protocol offers a starting point for researchers to obtain high-quality mass spectra. This guide is intended to empower researchers, scientists, and drug development professionals in their analytical endeavors involving  $\beta$ -keto nitriles and related structures.

## References

- ResearchGate. (2025, September 4). Electron ionization fragmentation studies of ethoxy and methoxymethyl substituted phenylacetones. Retrieved from [\[Link\]](#)
- DeRuiter, J., Abdel-Hay, K. M., & Clark, C. R. (n.d.). Chromatographic and Mass Spectral Studies on Methoxy Methyl Methamphetamines Related to 3,4-Methylenedioxymethamphetamine.
- Doc Brown's Advanced Organic Chemistry. (2025, November 13). mass spectrum of 2-methoxypropane C<sub>4</sub>H<sub>10</sub>O CH<sub>3</sub>CH(OCH<sub>3</sub>)CH<sub>3</sub> fragmentation pattern of m/z m/e ions for analysis and identification of methyl isopropyl ether. Retrieved from [\[Link\]](#)
- Chemistry LibreTexts. (2023, August 29). Mass Spectrometry - Fragmentation Patterns. Retrieved from [\[Link\]](#)
- PubChem. (n.d.). 4-Methoxy-3-methylphenylacetone nitrile. Retrieved from [\[Link\]](#)
- PubChem. (n.d.). 4-Methyl-3-oxopentanenitrile. Retrieved from [\[Link\]](#)
- NIST WebBook. (n.d.). Benzeneacetone nitrile, 4-methoxy-. Retrieved from [\[Link\]](#)
- PubChem. (n.d.). 4-Methoxybenzoyl nitrile. Retrieved from [\[Link\]](#)
- Unknown. (n.d.).
- ResearchGate. (n.d.). Fragmentation pathway involving the nitrile form of.... Retrieved from [\[Link\]](#)

- ResearchGate. (n.d.). Summary of the proposed fragmentation pathways for compounds 3a and 4a.... Retrieved from [[Link](#)]
- PubMed. (2020, June 30). Mass spectral fragmentation analyses of isotopically labelled hydroxy steroids using gas chromatography/electron ionization low-resolution mass spectrometry: A practical approach. Retrieved from [[Link](#)]
- PubMed. (2025, April 30). Characterization of Mass Spectrometry Fragmentation Patterns Under Electron-Activated Dissociation (EAD) for Rapid Structure Identification of Nitazene Analogs. Retrieved from [[Link](#)]
- University of Louisville. (n.d.). Fragmentation of oxime and silyl oxime ether oddelectron positive ions by the McLafferty rearrangement.
- Spectroscopy Online. (n.d.). Anatomy of an Ion's Fragmentation After Electron Ionization, Part I. Retrieved from [[Link](#)]
- PubChemLite. (n.d.). 4-methoxy-3-methylphenylacetonitrile (C<sub>10</sub>H<sub>11</sub>NO). Retrieved from [[Link](#)]
- YouTube. (2022, December 27). Lec-34 || Mass Fragmentation Pattern of Nitriles || McLafferty rearrangement || Nitrogen rule. Retrieved from [[Link](#)]
- PubChem. (n.d.). 4-Methoxy-3-oxobutanal. Retrieved from [[Link](#)]

### Need Custom Synthesis?

BenchChem offers custom synthesis for rare earth carbides and specific isotopic labeling.

Email: [info@benchchem.com](mailto:info@benchchem.com) or [Request Quote Online](#).

## Sources

- 1. [pdf.benchchem.com](https://pdf.benchchem.com) [[pdf.benchchem.com](https://pdf.benchchem.com)]
- 2. [mass spectrum of 2-methoxypropane C<sub>4</sub>H<sub>10</sub>O CH<sub>3</sub>CH\(OCH<sub>3</sub>\)CH<sub>3</sub> fragmentation pattern of m/z m/e ions for analysis and identification of methyl isopropyl ether image diagram doc brown's advanced organic chemistry revision notes](#) [[docbrown.info](https://docbrown.info)]

- [3. chemistry.miamioh.edu \[chemistry.miamioh.edu\]](https://chemistry.miamioh.edu)
- [4. louisville.edu \[louisville.edu\]](https://louisville.edu)
- [5. youtube.com \[youtube.com\]](https://youtube.com)
- [6. researchgate.net \[researchgate.net\]](https://researchgate.net)
- To cite this document: BenchChem. [Application Note: Elucidating the Mass Spectrometry Fragmentation Pattern of 4-Methoxy-3-oxopentanenitrile]. BenchChem, [2026]. [Online PDF]. Available at: [<https://www.benchchem.com/product/b1530771/docs#application-note-elucidating-the-mass-spectrometry-fragmentation-pattern-of-4-methoxy-3-oxopentanenitrile>]

---

### Disclaimer & Data Validity:

The information provided in this document is for Research Use Only (RUO) and is strictly not intended for diagnostic or therapeutic procedures. While BenchChem strives to provide accurate protocols, we make no warranties, express or implied, regarding the fitness of this product for every specific experimental setup.

**Technical Support:** The protocols provided are for reference purposes. Unsure if this reagent suits your experiment?

**Need Industrial/Bulk Grade?** [Request Custom Synthesis Quote](#)

## BenchChem

Our mission is to be the trusted global source of essential and advanced chemicals, empowering scientists and researchers to drive progress in science and industry.

### Contact

Address: 3281 E Guasti Rd  
Ontario, CA 91761, United States  
Phone: (601) 213-4426  
Email: [info@benchchem.com](mailto:info@benchchem.com)

[Contact our Ph.D. Support Team for a compatibility check](#)

