

Vishnu: A Technical Framework for Collaborative Neuroscience Research

Author: BenchChem Technical Support Team. **Date:** April 2026

Compound of Interest

Compound Name:	Vishnu
CAS No.:	135154-02-8
Cat. No.:	B153949

[Get Quote](#)

For Immediate Release

This technical guide provides an in-depth overview of the **Vishnu** software, a platform designed to foster collaborative scientific research, with a particular focus on neuroscience and drug development. Developed by the Visualization & Graphics Lab, **Vishnu** is a key component of the EBRAINS research infrastructure, which is powered by the Human Brain Project. This document is intended for researchers, scientists, and professionals in the field of drug development who are seeking to leverage advanced computational tools for data integration, analysis, and real-time collaboration.

Core Architecture and Functionality

Vishnu serves as a centralized framework for the integration and storage of scientific data from a multitude of sources, including in-vivo, in-vitro, and in-silico experiments.[1] The platform is engineered to handle data across different biological species and at various scales, making it a versatile tool for comprehensive research projects.

The core of the **Vishnu** framework is its application suite, which includes DC Explorer, Pyramidal Explorer, and CInt Explorer.^{[1][2]} **Vishnu** acts as a unified access point to these specialized tools and manages a centralized database for user datasets.^{[1][2]} This integrated environment is designed to streamline the research workflow, from data ingestion to in-depth analysis and visualization.

A primary function of **Vishnu** is to act as a communication framework that enables real-time information exchange and cooperation among researchers.^{[1][2]} This is facilitated through a secure and collaborative environment provided by the EBRAINS Collaboratory, which allows researchers to share their projects and data with specific users, teams, or the broader scientific community.

Data Ingestion and Compatibility

To accommodate the diverse data formats used in scientific research, **Vishnu** supports a range of file types for data input. The supported formats are summarized in the table below.

Data Format	File Extension	Description
Comma-Separated Values	.csv	A delimited text file that uses a comma to separate values.
JavaScript Object Notation	.json	A lightweight data-interchange format that is easy for humans to read and write and easy for machines to parse and generate.
Extensible Markup Language	.xml	A markup language that defines a set of rules for encoding documents in a format that is both human-readable and machine-readable.
EspINA	.espina	A specialized format for neural simulations.
Blueconfig	.blueconfig	A configuration file format used in the Blue Brain Project.

Table 1: Supported Data Input Formats in **Vishnu**

The Vishnu Application Suite

The **Vishnu** platform provides a gateway to a suite of powerful data exploration and analysis tools. Each tool is designed to address specific aspects of scientific data analysis.

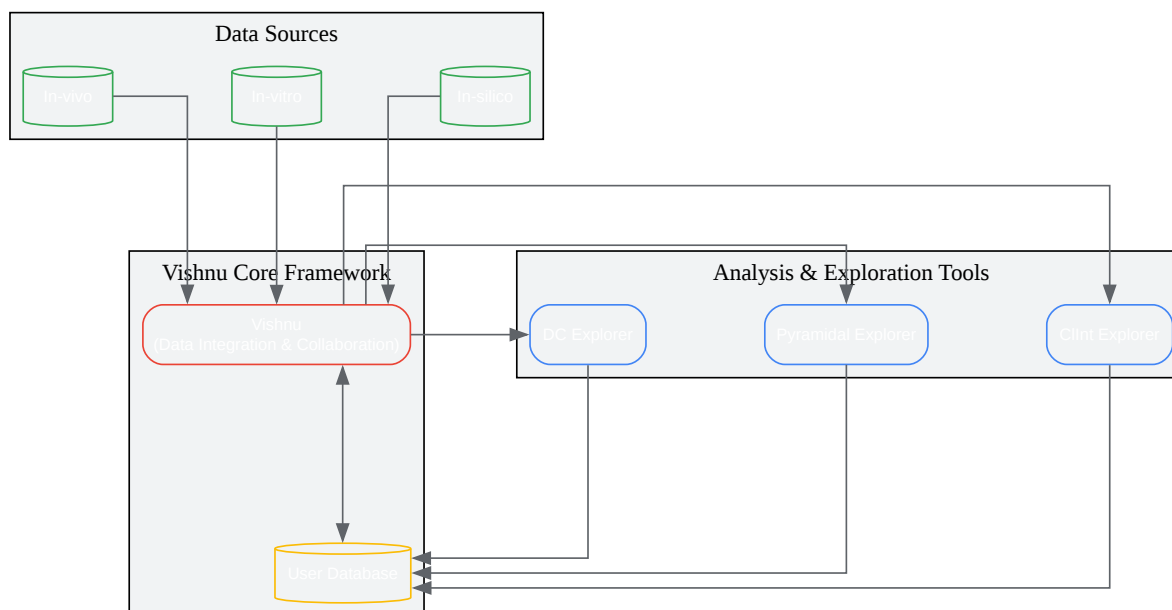

[Click to download full resolution via product page](#)

Figure 1: High-level architecture of the **Vishnu** framework.

DC Explorer

While specific functionalities of DC Explorer are not detailed in the available documentation, its role as a core component of the **Vishnu** suite suggests it is a primary tool for initial data exploration and analysis.

Pyramidal Explorer

Similarly, detailed documentation on Pyramidal Explorer is not publicly available. Given its name, it can be inferred that this tool may be specialized for the analysis of pyramidal neurons, a key component of the cerebral cortex, which aligns with the neuroscience focus of the Human Brain Project.

ClInt Explorer

Information regarding the specific functions of ClInt Explorer is also not readily available. It is likely a specialized tool for a particular type of data analysis within the **Vishnu** ecosystem.

Experimental Protocols and Methodologies

The **Vishnu** software is designed to be agnostic to the specific experimental protocols that generate the data. Its primary role is to provide a platform for the integration and collaborative analysis of the data post-generation. As such, detailed experimental protocols are not embedded within the software itself but are rather associated with the datasets that are imported by the users.

Researchers using **Vishnu** are expected to follow established best practices and standardized protocols within their respective fields for data acquisition. The platform then provides the tools to manage, share, and analyze this data in a collaborative manner.

Collaborative Research Workflow

The collaborative workflow within the **Vishnu** ecosystem is designed to be flexible and adaptable to the needs of different research projects. The following diagram illustrates a typical logical workflow for a collaborative research project using **Vishnu**.

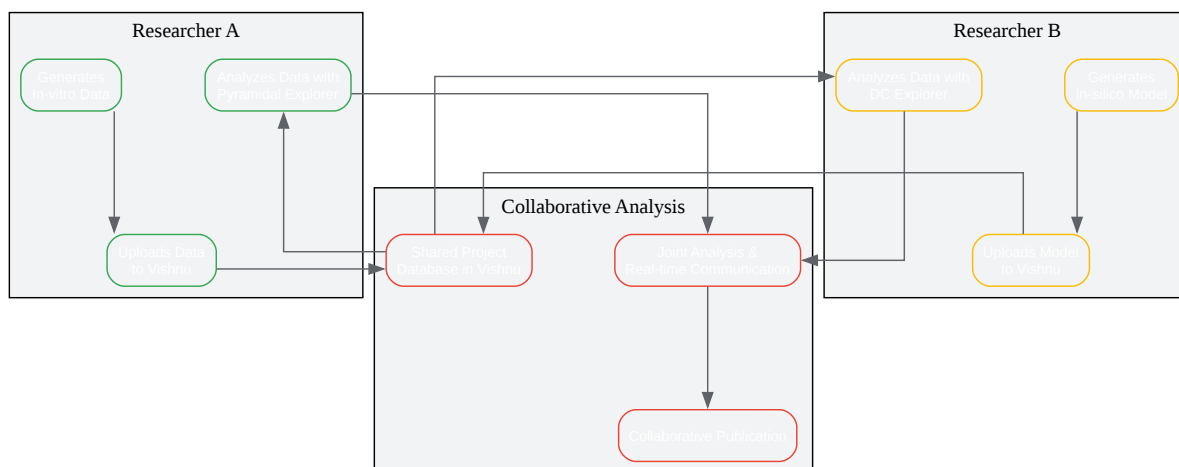

[Click to download full resolution via product page](#)

Figure 2: A logical workflow for collaborative research using **Vishnu**.

Conclusion and Future Directions

The **Vishnu** software, as part of the EBRAINS infrastructure, represents a significant step forward in facilitating collaborative scientific research, particularly in the data-intensive field of neuroscience. By providing a unified platform for data integration, specialized analysis tools, and real-time collaboration, **Vishnu** has the potential to accelerate the pace of discovery in drug development and our understanding of the human brain.

Future development of the **Vishnu** platform will likely focus on expanding the range of supported data formats, enhancing the capabilities of the integrated analysis tools, and improving the user interface to further streamline the collaborative research process. As the volume and complexity of scientific data continue to grow, platforms like **Vishnu** will become increasingly indispensable for the scientific community.

It is important to note that while this guide provides an overview of the **Vishnu** software's core functionalities, in-depth technical specifications, quantitative performance data, and detailed experimental protocols are not extensively available in publicly accessible documentation. For more specific information, researchers are encouraged to consult the resources available on the EBRAINS website and the **Vishnu** GitHub repository.

Need Custom Synthesis?

BenchChem offers custom synthesis for rare earth carbides and specific isotopic labeling.

Email: info@benchchem.com or [Request Quote Online](#).

References

- [1. Vishnu | EBRAINS \[ebrains.eu\]](#)
- [2. EBRAINS - Knowledge Graph Search \[search.kg.ebrains.eu\]](#)
- To cite this document: BenchChem. [Vishnu: A Technical Framework for Collaborative Neuroscience Research]. BenchChem, [2026]. [Online PDF]. Available at: [\[https://www.benchchem.com/product/b153949/docs#vishnu-a-technical-framework-for-collaborative-neuroscience-research\]](https://www.benchchem.com/product/b153949/docs#vishnu-a-technical-framework-for-collaborative-neuroscience-research)

Disclaimer & Data Validity:

The information provided in this document is for Research Use Only (RUO) and is strictly not intended for diagnostic or therapeutic procedures. While BenchChem strives to provide accurate protocols, we make no warranties, express or implied, regarding the fitness of this product for every specific experimental setup.

Technical Support: The protocols provided are for reference purposes. Unsure if this reagent suits your experiment?

Need Industrial/Bulk Grade? [Request Custom Synthesis Quote](#)

BenchChem

Our mission is to be the trusted global source of essential and advanced chemicals, empowering scientists and researchers to drive progress in science and industry.

Contact

Address: 3281 E Guasti Rd

Ontario, CA 91761, United States

Phone: (601) 213-4426

Email: info@benchchem.com

[Contact our Ph.D. Support Team for a compatibility check](#)