

Application Note: A Modular Approach to PROTAC Synthesis Employing a Piperazine-Based Linker

Author: BenchChem Technical Support Team. **Date:** May 2026

Compound of Interest

Compound Name:	<i>tert-Butyl 4-(2-(methylamino)ethyl)piperazine-1-carboxylate</i>
CAS No.:	539822-98-5
Cat. No.:	B153281

[Get Quote](#)

For Researchers, Scientists, and Drug Development Professionals

Abstract

This document provides a detailed experimental framework for the synthesis of Proteolysis-Targeting Chimeras (PROTACs), with a specific focus on the strategic incorporation of the bifunctional linker, **tert-butyl 4-(2-(methylamino)ethyl)piperazine-1-carboxylate** (CAS 539822-98-5). It is critical to clarify that this molecule serves as a versatile linker, not a von Hippel-Lindau (VHL) E3 ligase ligand as may be misconstrued. We will delineate the role of this linker and provide a representative, modular protocol for its conjugation to a VHL ligand and a ligand for a protein of interest (POI), thereby constructing a functional PROTAC.

Introduction: The Logic of PROTAC Design

PROTACs are heterobifunctional molecules that commandeer the cell's ubiquitin-proteasome system to induce the degradation of specific target proteins.[1][2] Their tripartite structure is the cornerstone of their function: a ligand for the POI, a ligand for an E3 ubiquitin ligase, and a linker that tethers them. The successful formation of a stable ternary complex between the POI, the PROTAC, and the E3 ligase is paramount for efficient protein degradation.[2] The choice of each component is a critical determinant of the final PROTAC's potency, selectivity, and pharmacokinetic properties.

The von Hippel-Lindau (VHL) E3 ligase is frequently recruited in PROTAC design due to its widespread expression and the availability of high-affinity, well-characterized small molecule ligands.[3][4] These ligands, such as derivatives of (S,R,S)-AHPC, serve as the anchor to the E3 ligase machinery.[5][6][7][8]

The linker, far from being a passive spacer, plays a crucial role in orienting the two ligands for optimal ternary complex formation. The linker's length, rigidity, and hydrophilicity can significantly impact the efficacy of the resulting PROTAC.[9] The subject of this guide, **tert-butyl 4-(2-(methylamino)ethyl)piperazine-1-carboxylate** (CAS 539822-98-5), is a bifunctional linker that can be readily incorporated into PROTAC synthesis.[10][11][12]

Component Analysis and Synthetic Strategy

The VHL Ligand: (S,R,S)-AHPC Derivatives

A commonly employed VHL ligand is (S,R,S)-AHPC, often functionalized with a reactive handle for linker attachment.[13] For the purpose of this protocol, we will consider a derivative with a terminal carboxylic acid, such as (S,R,S)-AHPC-PEG5-COOH, which allows for standard amide bond formation.[1]

The Linker: **tert-Butyl 4-(2-(methylamino)ethyl)piperazine-1-carboxylate (CAS 539822-98-5)**

This linker possesses two key reactive sites: a secondary methylamine and a Boc-protected primary amine on the piperazine ring. This differential protection allows for sequential, controlled conjugation. The secondary amine can be acylated by the VHL ligand, and after deprotection of the Boc group, the resulting primary amine can be coupled to the POI ligand.

The Protein of Interest (POI) Ligand

The choice of the POI ligand is entirely dependent on the target protein to be degraded. For this protocol, we will assume a generic POI ligand that has been functionalized with a carboxylic acid, rendering it ready for amide coupling.

Overall Synthetic Workflow

The synthetic strategy will proceed in a stepwise fashion:

- Step 1: Amide coupling of the VHL ligand to the linker. The carboxylic acid of the VHL ligand will be activated and reacted with the secondary amine of the linker.
- Step 2: Deprotection of the linker. The Boc protecting group on the piperazine will be removed to expose the primary amine.
- Step 3: Amide coupling of the POI ligand. The carboxylic acid of the POI ligand will be activated and reacted with the newly exposed primary amine of the VHL ligand-linker conjugate to yield the final PROTAC.

Visualizing the Synthetic Workflow

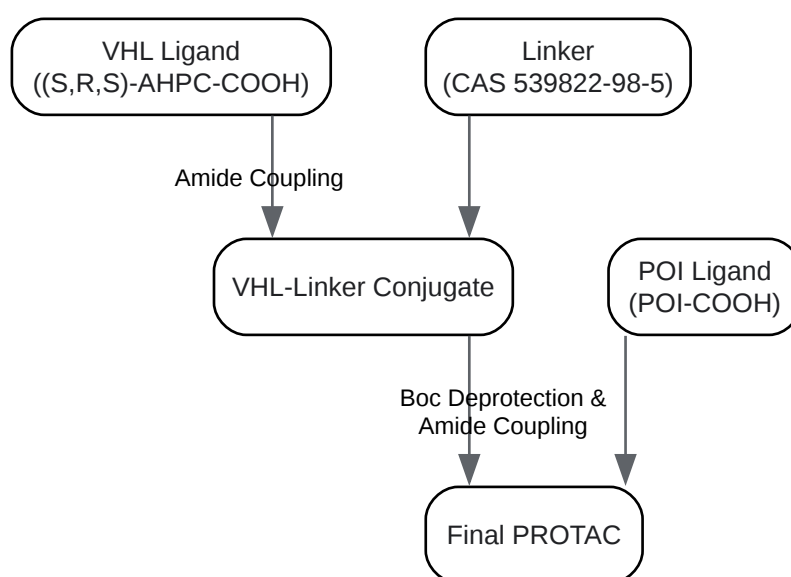

[Click to download full resolution via product page](#)

Figure 1: A simplified workflow for the synthesis of a VHL-based PROTAC.

Detailed Experimental Protocol

Materials and Reagents

Reagent	Supplier	Notes
(S,R,S)-AHPC-based VHL Ligand with COOH terminal	Various	e.g., (S,R,S)-AHPC-PEG5-COOH
tert-Butyl 4-(2-(methylamino)ethyl)piperazine-1-carboxylate	Various	CAS: 539822-98-5
POI Ligand with COOH terminal	In-house/Variou	Target-specific
HATU (Hexafluorophosphate Azabenzotriazole Tetramethyl Uronium)	Sigma-Aldrich	Amide coupling agent
DIPEA (N,N-Diisopropylethylamine)	Sigma-Aldrich	Base
DMF (N,N-Dimethylformamide)	Sigma-Aldrich	Anhydrous, reaction solvent
TFA (Trifluoroacetic acid)	Sigma-Aldrich	For Boc deprotection
DCM (Dichloromethane)	Sigma-Aldrich	Anhydrous, solvent
Saturated aqueous NaHCO ₃ solution	In-house	For workup
Brine	In-house	For workup
Anhydrous Na ₂ SO ₄ or MgSO ₄	Sigma-Aldrich	Drying agent
Solvents for chromatography (e.g., Hexanes, Ethyl Acetate)	Various	For purification

Step 1: Synthesis of the VHL-Linker Conjugate

- To a solution of the VHL ligand (1.0 eq) in anhydrous DMF, add HATU (1.2 eq) and DIPEA (3.0 eq).

- Stir the mixture at room temperature for 15 minutes to activate the carboxylic acid.
- Add a solution of **tert-butyl 4-(2-(methylamino)ethyl)piperazine-1-carboxylate** (1.1 eq) in anhydrous DMF to the reaction mixture.
- Stir the reaction at room temperature for 4-16 hours. Monitor the reaction progress by LC-MS.
- Upon completion, dilute the reaction mixture with ethyl acetate and wash with saturated aqueous NaHCO₃ solution (3x) and brine (1x).
- Dry the organic layer over anhydrous Na₂SO₄, filter, and concentrate under reduced pressure.
- Purify the crude product by flash column chromatography to yield the VHL-Linker conjugate.

Step 2: Boc Deprotection of the VHL-Linker Conjugate

- Dissolve the purified VHL-Linker conjugate (1.0 eq) in DCM.
- Add TFA (10-20% v/v) to the solution.
- Stir the reaction at room temperature for 1-2 hours. Monitor the reaction progress by LC-MS.
- Upon completion, concentrate the reaction mixture under reduced pressure to remove the TFA and DCM.
- The resulting amine salt is typically used in the next step without further purification.

Step 3: Synthesis of the Final PROTAC

- To a solution of the POI ligand (1.0 eq) in anhydrous DMF, add HATU (1.2 eq) and DIPEA (3.0 eq).
- Stir the mixture at room temperature for 15 minutes.
- Add a solution of the deprotected VHL-Linker conjugate (from Step 2, 1.1 eq) and additional DIPEA (2.0 eq, to neutralize the TFA salt) in anhydrous DMF.

- Stir the reaction at room temperature for 4-16 hours. Monitor the reaction progress by LC-MS.
- Workup the reaction as described in Step 1.5.
- Purify the final PROTAC by preparative HPLC to yield the desired product.

Characterization

The final PROTAC should be characterized by:

- LC-MS: To confirm the molecular weight and purity.
- ^1H and ^{13}C NMR: To confirm the structure.
- High-Resolution Mass Spectrometry (HRMS): To confirm the elemental composition.

Mechanism of Action Visualization

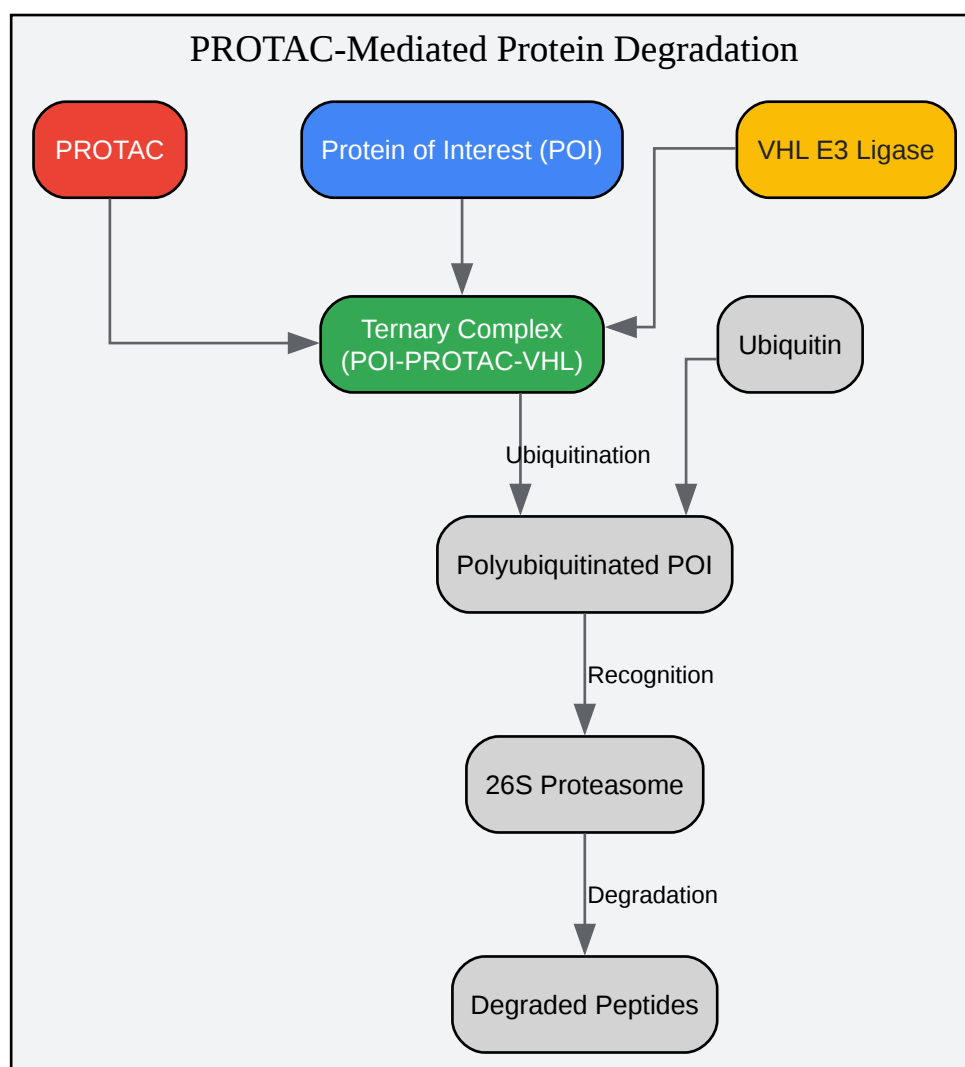

[Click to download full resolution via product page](#)

Figure 2: The catalytic cycle of PROTAC-induced protein degradation.

Trustworthiness and Self-Validation

The success of this protocol relies on careful monitoring at each step.

- **Reaction Monitoring:** LC-MS is an indispensable tool to track the consumption of starting materials and the formation of products. This allows for real-time adjustments to reaction times and conditions.

- Purification: Chromatographic purification at each step is crucial to remove unreacted starting materials and side products, ensuring the purity of the intermediates and the final PROTAC.
- Structural Verification: Comprehensive characterization of the final product by NMR and HRMS is non-negotiable to confirm its identity and purity.

Conclusion

This application note provides a robust and modular protocol for the synthesis of VHL-based PROTACs utilizing the linker **tert-butyl 4-(2-(methylamino)ethyl)piperazine-1-carboxylate** (CAS 539822-98-5). By understanding the distinct roles of the VHL ligand, the linker, and the POI ligand, researchers can rationally design and synthesize novel PROTACs for targeted protein degradation. The provided step-by-step methodology, coupled with in-process controls, offers a reliable path to obtaining high-purity PROTACs for biological evaluation.

References

- Design, Synthesis and Biological Evaluation of Proteolysis Targeting Chimeras (PROTACs) as a BTK Degraders with Improved Pharmacokinetic Properties. National Institutes of Health. [\[Link\]](#)
- Synthesis and Biological Activity of a VHL-Based PROTAC Specific for p38 α . National Institutes of Health. [\[Link\]](#)
- PROTAC-VHL-ligand|CAS 1448297-52-6. DC Chemicals. [\[Link\]](#)
- Systematic Potency and Property Assessment of VHL Ligands and Implications on PROTAC Design. ResearchGate. [\[Link\]](#)
- Discovery of small molecule ligands for the von Hippel-Lindau (VHL) E3 ligase and their use as inhibitors and PROTAC degraders. Royal Society of Chemistry. [\[Link\]](#)
- Chemical design, synthesis and biological evaluation of novel proteolysis targeting chimeras (PROTACs) for the degradation of NUDT5. DiVA portal. [\[Link\]](#)

- Journey of Von Hippel-Lindau (VHL) E3 ligase in PROTACs design: From VHL ligands to VHL-based degraders. PubMed. [[Link](#)]
- A patent review of von Hippel-Lindau (VHL)-recruiting chemical matter: E3 ligase ligands for PROTACs and targeted protein degradation (2019–present). National Institutes of Health. [[Link](#)]

Need Custom Synthesis?

BenchChem offers custom synthesis for rare earth carbides and specific isotopic labeling.

Email: info@benchchem.com or [Request Quote Online](#).

Sources

- 1. [medkoo.com](https://www.medkoo.com) [[medkoo.com](https://www.medkoo.com)]
- 2. [benchchem.com](https://www.benchchem.com) [[benchchem.com](https://www.benchchem.com)]
- 3. Journey of Von Hippel-Lindau (VHL) E3 ligase in PROTACs design: From VHL ligands to VHL-based degraders - PubMed [pubmed.ncbi.nlm.nih.gov]
- 4. A patent review of von Hippel-Lindau (VHL)-recruiting chemical matter: E3 ligase ligands for PROTACs and targeted protein degradation (2019–present) - PMC [pmc.ncbi.nlm.nih.gov]
- 5. [medchemexpress.com](https://www.medchemexpress.com) [[medchemexpress.com](https://www.medchemexpress.com)]
- 6. [medchemexpress.com](https://www.medchemexpress.com) [[medchemexpress.com](https://www.medchemexpress.com)]
- 7. [medchemexpress.com](https://www.medchemexpress.com) [[medchemexpress.com](https://www.medchemexpress.com)]
- 8. [medchemexpress.com](https://www.medchemexpress.com) [[medchemexpress.com](https://www.medchemexpress.com)]
- 9. PROTAC Synthesis Kits for Targeted Protein Degradation [[sigmaaldrich.com](https://www.sigmaaldrich.com)]
- 10. [medchemexpress.com](https://www.medchemexpress.com) [[medchemexpress.com](https://www.medchemexpress.com)]
- 11. [medchemexpress.com](https://www.medchemexpress.com) [[medchemexpress.com](https://www.medchemexpress.com)]
- 12. [medchemexpress.com](https://www.medchemexpress.com) [[medchemexpress.com](https://www.medchemexpress.com)]
- 13. PROTAC-VHL-ligand|CAS 1448297-52-6|DC Chemicals [[dcchemicals.com](https://www.dcchemicals.com)]
- To cite this document: BenchChem. [Application Note: A Modular Approach to PROTAC Synthesis Employing a Piperazine-Based Linker]. BenchChem, [2026]. [[Online PDF](#)].

Available at: [<https://www.benchchem.com/product/b153281/docs#application-note-a-modular-approach-to-protac-synthesis-employing-a-piperazine-based-linker>]

Disclaimer & Data Validity:

The information provided in this document is for Research Use Only (RUO) and is strictly not intended for diagnostic or therapeutic procedures. While BenchChem strives to provide accurate protocols, we make no warranties, express or implied, regarding the fitness of this product for every specific experimental setup.

Technical Support: The protocols provided are for reference purposes. Unsure if this reagent suits your experiment?

Need Industrial/Bulk Grade? [Request Custom Synthesis Quote](#)

BenchChem

Our mission is to be the trusted global source of essential and advanced chemicals, empowering scientists and researchers to drive progress in science and industry.

Contact

Address: 3281 E Guasti Rd
Ontario, CA 91761, United States
Phone: (601) 213-4426
Email: info@benchchem.com

[Contact our Ph.D. Support Team for a compatibility check](#)