

A Guide to the Spectroscopic Characterization of Methyl 2-Pentynoate

Author: BenchChem Technical Support Team. **Date:** May 2026

Compound of Interest

Compound Name: METHYL 2-PENTYNOATE

CAS No.: 24342-04-9

Cat. No.: B153096

[Get Quote](#)

Abstract

This technical guide provides a comprehensive overview of the spectroscopic properties of **methyl 2-pentynoate** (CAS No. 24342-04-9), a valuable building block in organic synthesis. While readily available experimental spectra for this compound are scarce in public databases, this document leverages fundamental principles of nuclear magnetic resonance (NMR) spectroscopy, infrared (IR) spectroscopy, and mass spectrometry (MS) to predict and interpret its spectral data. This guide is intended for researchers, scientists, and professionals in drug development who require a deep understanding of the structural elucidation of acetylenic esters. We will explore the theoretical underpinnings of the expected spectral features, provide detailed protocols for data acquisition, and present the predicted data in a clear, tabular format for ease of reference.

Introduction: The Structural Significance of Methyl 2-Pentynoate

Methyl 2-pentynoate, with the linear formula $\text{CH}_3\text{CH}_2\text{C}\equiv\text{CCO}_2\text{CH}_3$, is an organic compound featuring two key functional groups: a terminal ethyl group attached to an internal alkyne and a

methyl ester. This combination of an electron-withdrawing ester group conjugated with a carbon-carbon triple bond makes it a versatile reagent in various chemical transformations, including cycloadditions, transition-metal-catalyzed cross-coupling reactions, and the synthesis of complex heterocyclic systems.

Accurate structural verification of **methyl 2-pentynoate** is paramount for its effective use in synthesis. Spectroscopic methods provide a non-destructive and highly informative means of confirming its identity and purity. This guide will delve into the predicted ^1H NMR, ^{13}C NMR, IR, and MS data, offering a roadmap for its characterization.

Nuclear Magnetic Resonance (NMR) Spectroscopy

NMR spectroscopy is arguably the most powerful tool for the structural elucidation of organic molecules. By probing the magnetic environments of ^1H and ^{13}C nuclei, we can deduce the connectivity and chemical nature of the atoms within the molecule.

Predicted ^1H NMR Spectrum

The proton NMR spectrum of **methyl 2-pentynoate** is expected to show three distinct signals, each corresponding to the chemically non-equivalent protons in the molecule. The deshielding effect of the ester and the anisotropic effect of the alkyne are key to predicting the chemical shifts.

- **Methyl Protons (-OCH₃):** The three protons of the methyl ester group are expected to appear as a sharp singlet. Their proximity to the electronegative oxygen atom will cause a downfield shift.
- **Methylene Protons (-CH₂-):** The two protons of the methylene group are adjacent to the sp-hybridized carbon of the alkyne. They will exhibit a triplet splitting pattern due to coupling with the neighboring methyl protons.
- **Terminal Methyl Protons (-CH₃):** The three protons of the terminal methyl group will appear as a triplet, coupled to the adjacent methylene protons.

Predicted ^{13}C NMR Spectrum

The proton-decoupled ^{13}C NMR spectrum of **methyl 2-pentynoate** should display six unique signals, one for each carbon atom in its distinct chemical environment. The chemical shifts are influenced by hybridization and proximity to electronegative atoms.

- Carbonyl Carbon ($\text{C}=\text{O}$): The ester carbonyl carbon is the most deshielded and will appear significantly downfield.
- Alkynyl Carbons ($-\text{C}\equiv\text{C}-$): The two sp -hybridized carbons of the alkyne will have characteristic chemical shifts in the mid-range of the spectrum.
- Methyl Ester Carbon ($-\text{OCH}_3$): The carbon of the methyl ester will be influenced by the adjacent oxygen atom.
- Methylene Carbon ($-\text{CH}_2-$): The methylene carbon will appear in the aliphatic region.
- Terminal Methyl Carbon ($-\text{CH}_3$): The terminal methyl carbon will be the most shielded and appear furthest upfield.

NMR Data Summary

The predicted NMR data for **methyl 2-pentynoate** is summarized in the table below.

^1H NMR	Predicted Chemical Shift (δ , ppm)	Multiplicity	Integration	Assignment
Methyl Protons	~3.7	Singlet	3H	$-\text{OCH}_3$
Methylene Protons	~2.3	Quartet	2H	$-\text{CH}_2-$
Terminal Methyl Protons	~1.1	Triplet	3H	$-\text{CH}_2\text{CH}_3$

¹³ C NMR	Predicted Chemical Shift (δ , ppm)	Assignment
Carbonyl Carbon	~154	C=O
Alkynyl Carbon	~85	-C \equiv C-CO ₂ CH ₃
Alkynyl Carbon	~75	-C \equiv C-CO ₂ CH ₃
Methyl Ester Carbon	~52	-OCH ₃
Methylene Carbon	~13	-CH ₂ -
Terminal Methyl Carbon	~12	-CH ₂ CH ₃

Infrared (IR) Spectroscopy

IR spectroscopy is an excellent technique for identifying the presence of specific functional groups within a molecule. Each functional group absorbs infrared radiation at a characteristic frequency, corresponding to its vibrational modes.

For **methyl 2-pentynoate**, the following key absorption bands are predicted:

- **C \equiv C Stretch:** The carbon-carbon triple bond of the internal alkyne will exhibit a sharp, and likely weak, absorption in the range of 2100-2260 cm⁻¹.^{[1][2]} The conjugation with the carbonyl group may influence the intensity and exact position of this peak.
- **C=O Stretch:** The carbonyl group of the ester will show a strong, sharp absorption band around 1715-1735 cm⁻¹.^{[3][4]} Conjugation with the alkyne is expected to shift this absorption to a slightly lower wavenumber compared to a saturated ester.
- **C-O Stretch:** The C-O single bond of the ester will have a strong absorption in the fingerprint region, typically between 1000 and 1300 cm⁻¹.^[3]
- **sp³ C-H Stretch:** The C-H bonds of the methyl and methylene groups will show strong absorptions in the 2850-3000 cm⁻¹ region.^{[3][4]}

IR Data Summary

Vibrational Mode	Predicted Wavenumber (cm ⁻¹)	Intensity
sp ³ C-H Stretch	2850 - 3000	Strong
C≡C Stretch	2100 - 2260	Weak to Medium
C=O Stretch	1715 - 1735	Strong
C-O Stretch	1000 - 1300	Strong

Mass Spectrometry (MS)

Mass spectrometry provides information about the molecular weight and fragmentation pattern of a molecule, which is invaluable for confirming its structure.

- **Molecular Ion Peak (M⁺):** The molecular ion peak for **methyl 2-pentynoate** (C₆H₈O₂) is expected at a mass-to-charge ratio (m/z) of 112.13. This peak may be of low intensity due to the lability of the ester group.
- **Key Fragmentation Pathways:** Esters are known to undergo characteristic fragmentation patterns.^{[5][6][7]}
 - **α-Cleavage:** Cleavage of the bond adjacent to the carbonyl group can lead to the loss of the methoxy radical (•OCH₃, mass = 31), resulting in an acylium ion at m/z 81.
 - **Loss of the Ethyl Group:** Cleavage of the bond between the alkyne and the ethyl group can result in the loss of an ethyl radical (•CH₂CH₃, mass = 29), leading to a fragment at m/z 83.
 - **McLafferty Rearrangement:** While a classical McLafferty rearrangement is not possible due to the lack of a γ-hydrogen, other complex rearrangements can occur.

MS Data Summary

m/z	Predicted Fragment
112	[M] ⁺ (Molecular Ion)
81	[M - •OCH ₃] ⁺
83	[M - •CH ₂ CH ₃] ⁺
53	[C ₄ H ₅] ⁺ (Propargyl cation or related isomer)

Experimental Protocols

The following are generalized protocols for acquiring the spectral data discussed. Instrument parameters should be optimized for the specific equipment used.

NMR Spectroscopy

- **Sample Preparation:** Dissolve approximately 5-10 mg of **methyl 2-pentynoate** in 0.6-0.7 mL of a deuterated solvent (e.g., CDCl₃) in a clean, dry 5 mm NMR tube.[8] Add a small amount of tetramethylsilane (TMS) as an internal standard (0.00 ppm).
- **¹H NMR Acquisition:** Acquire the proton NMR spectrum on a spectrometer operating at a frequency of 300 MHz or higher. Typical parameters include a spectral width of 12-16 ppm, a pulse width of 30-45 degrees, a relaxation delay of 1-2 seconds, and an acquisition time of 2-4 seconds.
- **¹³C NMR Acquisition:** Acquire the carbon-13 NMR spectrum on the same sample. A typical operating frequency is 75 MHz or higher. Utilize proton decoupling to obtain a spectrum with singlets for each carbon.[9] Key parameters include a spectral width of 200-220 ppm, a pulse width of 30-45 degrees, a relaxation delay of 2-5 seconds, and a sufficient number of scans to achieve an adequate signal-to-noise ratio.
- **Data Processing:** Process the acquired data using appropriate software. This includes Fourier transformation, phase correction, baseline correction, and referencing the spectrum to the internal standard.

IR Spectroscopy

- Sample Preparation (Neat Liquid): Place a small drop of neat **methyl 2-pentynoate** between two potassium bromide (KBr) or sodium chloride (NaCl) salt plates to create a thin film.[10]
- Data Acquisition: Record the IR spectrum using a Fourier Transform Infrared (FTIR) spectrometer, typically over a range of 4000 to 400 cm^{-1} . Acquire a background spectrum of the empty salt plates first, which will be automatically subtracted from the sample spectrum. [11]

Mass Spectrometry

- Sample Introduction: Introduce a dilute solution of **methyl 2-pentynoate** in a volatile organic solvent (e.g., methanol or dichloromethane) into the mass spectrometer. Common introduction methods include direct infusion or via a gas chromatograph (GC-MS).[12]
- Ionization: Utilize a suitable ionization technique. Electron ionization (EI) is a common method that will induce fragmentation and provide structural information.
- Data Acquisition: Acquire the mass spectrum over a suitable m/z range (e.g., 40-200 amu). The instrument will separate the ions based on their mass-to-charge ratio.[13]

Integrated Spectroscopic Analysis Workflow

The following diagram illustrates the logical workflow for the structural elucidation of **methyl 2-pentynoate**, integrating information from each spectroscopic technique.

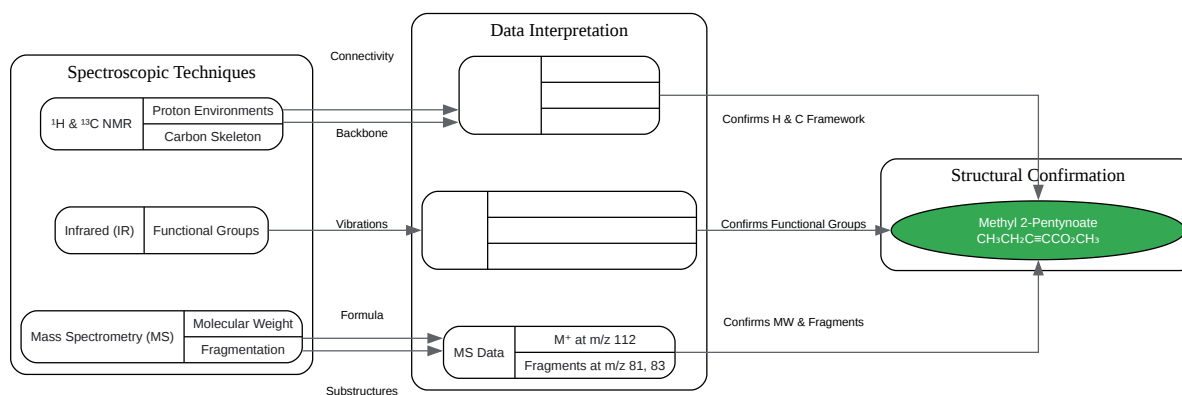

[Click to download full resolution via product page](#)

Caption: Integrated workflow for the structural elucidation of **methyl 2-pentynoate**.

Conclusion

The comprehensive analysis of predicted ^1H NMR, ^{13}C NMR, IR, and MS data provides a robust framework for the unambiguous identification of **methyl 2-pentynoate**. The expected chemical shifts, coupling constants, vibrational frequencies, and fragmentation patterns collectively form a unique spectral fingerprint for this compound. By understanding these predicted spectral characteristics and employing the outlined experimental protocols, researchers can confidently verify the synthesis and purity of **methyl 2-pentynoate**, ensuring its successful application in their scientific endeavors.

References

- JoVE. (2024). Mass Spectrometry: Carboxylic Acid, Ester, and Amide Fragmentation. Retrieved from [[Link](#)][5]

- TutorChase. (n.d.). What are the common fragments in mass spectrometry for esters? Retrieved from [\[Link\]](#)[6]
- Chemistry!!! Not Mystery. (2013). Fragmentation and mass spectra of Esters. Retrieved from [\[Link\]](#)[7]
- OpenOChem Learn. (n.d.). Alkynes. Retrieved from [\[Link\]](#)
- Chemistry LibreTexts. (2024). 12.8: Infrared Spectra of Some Common Functional Groups. Retrieved from [\[Link\]](#)[3][4]
- Frontier, A. (2026). How to Get a Good ^1H NMR Spectrum. University of Rochester, Department of Chemistry. Retrieved from [\[Link\]](#)
- YouTube. (2020). PART 14: ALIPHATIC ESTERS (MASS SPECTRUM FRAGMENTATION PATTERN) FOR CSIR NET/GATE. Retrieved from [\[Link\]](#)
- OpenStax. (2023). 12.8 Infrared Spectra of Some Common Functional Groups. Organic Chemistry. Retrieved from [\[Link\]](#)
- University of California, Los Angeles. (n.d.). Mass Spectrometry: Fragmentation. Retrieved from [\[Link\]](#)
- Wikipedia. (2024). Mass spectrometry. Retrieved from [\[Link\]](#)
- University of Leicester. (n.d.). NMR Sample Preparation. Retrieved from [\[Link\]](#)
- Oregon State University. (n.d.). ^{13}C NMR Chemical Shift. Retrieved from [\[Link\]](#)
- University of Calgary. (n.d.). IR: alkynes. Retrieved from [\[Link\]](#)[1]
- Chemistry LibreTexts. (2023). Spectroscopy of the Alkynes. Retrieved from [\[Link\]](#)[2]
- Iowa State University. (n.d.). NMR Sample Preparation. Chemical Instrumentation Facility. Retrieved from [\[Link\]](#)[8]
- Chemistry Steps. (n.d.). ^{13}C Carbon NMR Spectroscopy. Retrieved from [\[Link\]](#)[9]

- Chemistry Steps. (n.d.). NMR Chemical Shift Values Table. Retrieved from [[Link](#)]
- Chemistry LibreTexts. (2022). 4.2: IR Spectroscopy. Retrieved from [[Link](#)][10]
- ACD/Labs. (2023). A Beginner's Guide to Mass Spectrometry. Retrieved from [[Link](#)][13]

Need Custom Synthesis?

BenchChem offers custom synthesis for rare earth carbides and specific isotopic labeling.

Email: info@benchchem.com or [Request Quote Online](#).

Sources

1. orgchemboulder.com [orgchemboulder.com]
 2. chem.libretexts.org [chem.libretexts.org]
 3. chem.libretexts.org [chem.libretexts.org]
 4. 12.8 Infrared Spectra of Some Common Functional Groups - Organic Chemistry | OpenStax [openstax.org]
 5. Video: Mass Spectrometry: Carboxylic Acid, Ester, and Amide Fragmentation [jove.com]
 6. tutorchase.com [tutorchase.com]
 7. Chemistry!!! Not Mystery : Fragmentation and mass spectra of Esters [chemistrynotmystery.com]
 8. NMR Sample Preparation | Chemical Instrumentation Facility [cif.iastate.edu]
 9. 13C Carbon NMR Spectroscopy - Chemistry Steps [chemistrysteps.com]
 10. chem.libretexts.org [chem.libretexts.org]
 11. youtube.com [youtube.com]
 12. Mass Spectrometry Basics | Mass Spectrometry | JEOL USA [jeolusa.com]
 13. acdlabs.com [acdlabs.com]
- To cite this document: BenchChem. [A Guide to the Spectroscopic Characterization of Methyl 2-Pentynoate]. BenchChem, [2026]. [Online PDF]. Available at: [<https://www.benchchem.com/product/b153096/docs#a-guide-to-the-spectroscopic-characterization-of-methyl-2-pentynoate>]

Disclaimer & Data Validity:

The information provided in this document is for Research Use Only (RUO) and is strictly not intended for diagnostic or therapeutic procedures. While BenchChem strives to provide accurate protocols, we make no warranties, express or implied, regarding the fitness of this product for every specific experimental setup.

Technical Support: The protocols provided are for reference purposes. Unsure if this reagent suits your experiment?

Need Industrial/Bulk Grade? [Request Custom Synthesis Quote](#)

BenchChem

Our mission is to be the trusted global source of essential and advanced chemicals, empowering scientists and researchers to drive progress in science and industry.

Contact

Address: 3281 E Guasti Rd
Ontario, CA 91761, United States
Phone: (601) 213-4426
Email: info@benchchem.com

[Contact our Ph.D. Support Team for a compatibility check](#)