

# Application Notes and Protocols for Downstream Analysis of RAF Signaling

**Author:** BenchChem Technical Support Team. **Date:** April 2026

## Compound of Interest

Compound Name: *alpha-RA-F*

Cat. No.: *B15294726*

[Get Quote](#)

These application notes provide detailed protocols for researchers, scientists, and drug development professionals to analyze the downstream effects of modulating the RAF signaling pathway. The focus is on key techniques to assess the activity of the RAF-MEK-ERK cascade, a critical pathway in cell proliferation, differentiation, and survival. Dysregulation of this pathway is a hallmark of many cancers, making it a key target for therapeutic development.<sup>[1][2][3][4]</sup>

The protocols outlined below are designed to be adaptable for studying the effects of various stimuli, including novel activators (e.g., **alpha-RA-F**) or inhibitors of RAF.

## The RAF-MEK-ERK Signaling Pathway

The RAF-MEK-ERK pathway is a highly conserved signaling cascade that relays extracellular signals to the nucleus to control gene expression and cellular responses. The pathway is initiated by the activation of RAS proteins, which then recruit and activate RAF kinases (ARAF, BRAF, and CRAF). Activated RAF then phosphorylates and activates MEK1 and MEK2 (dual-specificity kinases), which in turn phosphorylate and activate ERK1 and ERK2 (also known as p44/42 MAPK). Phosphorylated ERK (p-ERK) translocates to the nucleus to regulate transcription factors, leading to changes in cell behavior.

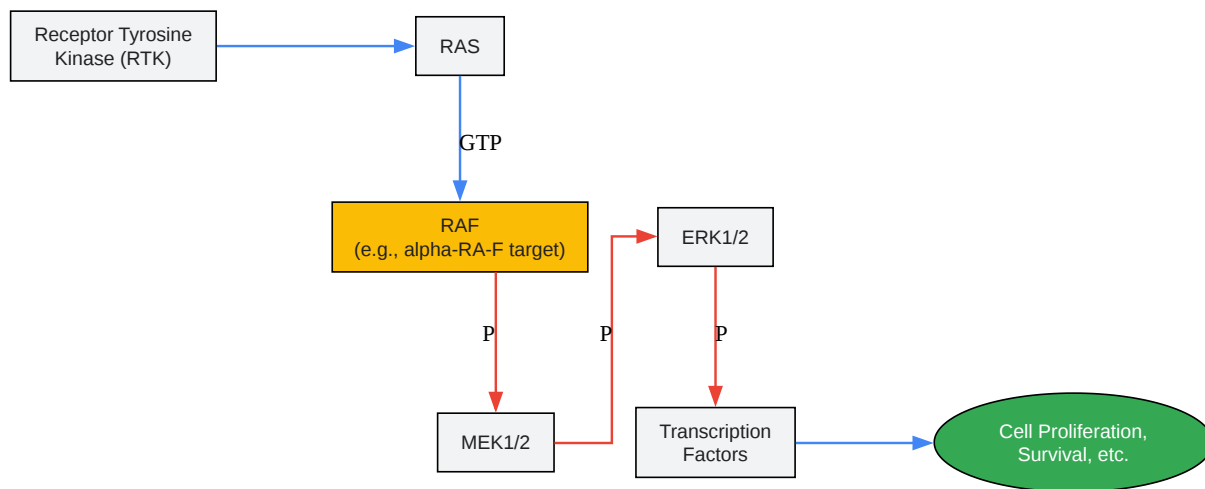

[Click to download full resolution via product page](#)

## Need Custom Synthesis?

BenchChem offers custom synthesis for rare earth carbides and specific isotopic labeling.

Email: [info@benchchem.com](mailto:info@benchchem.com) or [Request Quote Online](#).

## References

- [1. benchchem.com \[benchchem.com\]](#)
- [2. Dissecting RAF inhibitor resistance by structure-based modeling reveals ways to overcome oncogenic RAS signaling - PMC \[pmc.ncbi.nlm.nih.gov\]](#)
- [3. New perspectives for targeting RAF kinase in human cancer - PMC \[pmc.ncbi.nlm.nih.gov\]](#)
- [4. mdpi.com \[mdpi.com\]](#)
- To cite this document: BenchChem. [Application Notes and Protocols for Downstream Analysis of RAF Signaling]. BenchChem, [2026]. [Online PDF]. Available at: [\[https://www.benchchem.com/product/b15294726/docs#application-notes-and-protocols-for-downstream-analysis-of-raf-signaling\]](https://www.benchchem.com/product/b15294726/docs#application-notes-and-protocols-for-downstream-analysis-of-raf-signaling)

---

### Disclaimer & Data Validity:

The information provided in this document is for Research Use Only (RUO) and is strictly not intended for diagnostic or therapeutic procedures. While BenchChem strives to provide accurate protocols, we make no warranties, express or implied, regarding the fitness of this product for every specific experimental setup.

**Technical Support:** The protocols provided are for reference purposes. Unsure if this reagent suits your experiment?

**Need Industrial/Bulk Grade?** [Request Custom Synthesis Quote](#)

## BenchChem

Our mission is to be the trusted global source of essential and advanced chemicals, empowering scientists and researchers to drive progress in science and industry.

### Contact

Address: 3281 E Guasti Rd  
Ontario, CA 91761, United States  
Phone: (601) 213-4426  
Email: [info@benchchem.com](mailto:info@benchchem.com)

Contact our Ph.D. Support Team for a compatibility check