

An In-Depth Technical Guide to the Mechanism of Action of A-RAF

Author: BenchChem Technical Support Team. **Date:** April 2026

Compound of Interest

Compound Name: *alpha-RA-F*

Cat. No.: *B15294726*

[Get Quote](#)

For Researchers, Scientists, and Drug Development Professionals

Introduction

A-RAF, a member of the RAF family of serine/threonine kinases, is a critical component of the RAS-RAF-MEK-ERK mitogen-activated protein kinase (MAPK) signaling cascade. This pathway plays a pivotal role in regulating a wide array of cellular processes, including proliferation, differentiation, survival, and apoptosis. While extensively studied, the specific mechanistic nuances of A-RAF often remain in the shadow of its more frequently mutated and oncogenically implicated paralogs, B-RAF and C-RAF. This guide provides a comprehensive technical overview of the core mechanism of action of A-RAF, focusing on its activation, regulation, and key experimental methodologies for its study.

The A-RAF Signaling Pathway: A Step-by-Step Activation Mechanism

The activation of A-RAF is a tightly regulated, multi-step process initiated by upstream signals and culminating in the phosphorylation and activation of its downstream target, MEK.

- **Inactive State:** In quiescent cells, A-RAF exists in an autoinhibited, monomeric state in the cytoplasm. This inactive conformation is maintained through the interaction of its N-terminal regulatory domain with its C-terminal kinase domain. The binding of 14-3-3 proteins to phosphorylated serine residues, such as those in the CR2 and C-terminal regions, further stabilizes this autoinhibited state.
- **RAS-Mediated Recruitment and Activation:** Upon stimulation by growth factors or other mitogens, receptor tyrosine kinases (RTKs) activate the small GTPase RAS. GTP-bound, active RAS recruits A-RAF from the cytoplasm to the plasma membrane. This interaction occurs through the Ras-binding domain (RBD) located in the N-terminal region of A-RAF. Membrane localization is a critical step that relieves the autoinhibitory conformation of A-RAF, making it accessible for further activation steps.
- **Dimerization:** At the plasma membrane, the increased local concentration of RAF proteins facilitates their dimerization. A-RAF can form both homodimers (A-RAF/A-RAF) and heterodimers with other RAF isoforms (A-RAF/B-RAF or A-RAF/C-RAF). This side-to-side dimerization of the kinase domains is an essential prerequisite for A-RAF's catalytic activation.
- **Phosphorylation and Full Activation:** Dimerization facilitates a series of activating phosphorylation events within the kinase domain. Key activating phosphorylation sites in A-RAF include residues within the activation loop (T452 and T455) and the N-region of the kinase domain (S299 and Y302). Phosphorylation of these sites, mediated by other kinases (such as Src family kinases for Y302) and potentially through autophosphorylation, induces a conformational change that fully activates the A-RAF kinase.
- **MEK Phosphorylation:** Once fully active, A-RAF phosphorylates and activates its only known downstream substrates, MEK1 and MEK2. This phosphorylation occurs on two serine residues in the activation loop of MEK, leading to the propagation of the signal down the MAPK cascade to ERK and subsequent cellular responses.

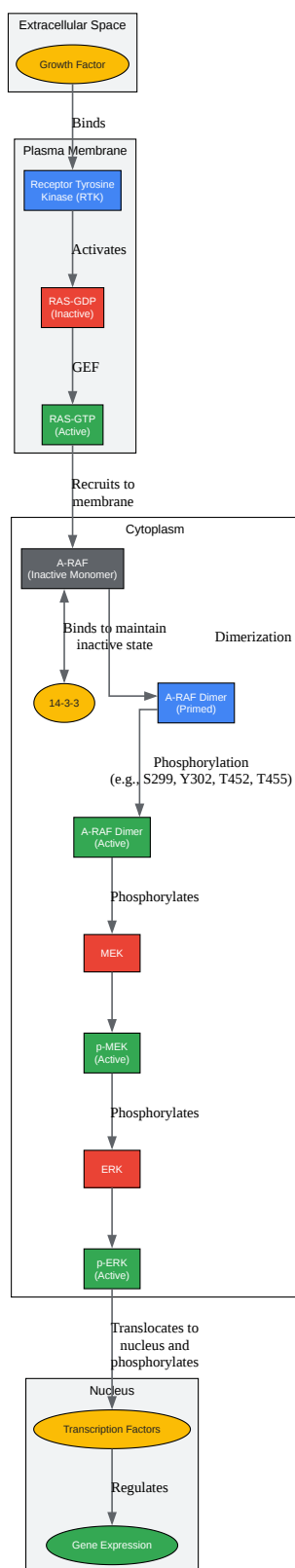

[Click to download full resolution via product page](#)

Figure 1: A-RAF Signaling Pathway

Quantitative Data on A-RAF

While A-RAF is the least potent MEK activator among the RAF isoforms, its role in signaling is significant, particularly in specific cellular contexts.[1] The following tables summarize available quantitative data for A-RAF.

Table 1: A-RAF Phosphorylation Sites and Their Functions

Phosphorylation Site	Function	Activating/Inhibitory	Kinase(s) / Phosphatase(s)	Reference(s)
S299	Corresponds to the activating S338 site in C-RAF.[2]	Activating	PAK	[2]
Y302	Corresponds to the activating Y341 site in C-RAF; crucial for activation by Src.[3]	Activating	Src family kinases	[3]
T452 / T455	Located in the activation loop; conserved activating sites.	Activating	Autophosphorylation/Upstream kinases	
S257 / S262 / S264	Located in the isoform-specific hinge (IH) segment; regulate A-RAF activation.	Activating	Unknown	
S432	Participates in MEK binding.	Activating	Unknown	

Table 2: IC50 Values of Inhibitors Against A-RAF

Inhibitor	Inhibitor Type	A-RAF IC50 (nM)	Reference(s)
Vemurafenib	Type I.5	~48	
Dabrafenib	Type I.5	9	
SB590885	Type I	~15	
Tovorafenib	Type II	Markedly less potent vs CRAF	
Naporafenib	Type II	Markedly less potent vs CRAF	

Experimental Protocols

Detailed methodologies are crucial for the accurate study of A-RAF. Below are foundational protocols for key experiments.

Co-Immunoprecipitation (Co-IP) of Endogenous A-RAF

This protocol describes the immunoprecipitation of endogenous A-RAF to identify interacting proteins.

Materials:

- Cell Lysis Buffer: 25 mM Tris-HCl pH 7.4, 150 mM NaCl, 1 mM EDTA, 1% NP-40, 5% glycerol, supplemented with protease and phosphatase inhibitors.
- Wash Buffer: Cell Lysis Buffer with a reduced detergent concentration (e.g., 0.1% NP-40).
- Anti-A-RAF antibody (validated for IP).
- Protein A/G magnetic beads or agarose beads.
- 2x Laemmli sample buffer.

Procedure:

- Cell Lysis:
 - Wash cultured cells with ice-cold PBS.
 - Lyse cells in ice-cold Lysis Buffer for 30 minutes on ice with occasional vortexing.
 - Centrifuge the lysate at 14,000 x g for 15 minutes at 4°C to pellet cell debris.
 - Transfer the supernatant (protein lysate) to a fresh, pre-chilled tube.
- Pre-clearing the Lysate (Optional but Recommended):
 - Add Protein A/G beads to the lysate and incubate for 1 hour at 4°C with gentle rotation to reduce non-specific binding.
 - Pellet the beads by centrifugation and transfer the supernatant to a new tube.
- Immunoprecipitation:
 - Add the anti-A-RAF antibody to the pre-cleared lysate (the optimal antibody concentration should be determined empirically).
 - Incubate for 2-4 hours or overnight at 4°C with gentle rotation.
- Capture of Immune Complexes:
 - Add pre-washed Protein A/G beads to the lysate-antibody mixture.
 - Incubate for 1-2 hours at 4°C with gentle rotation.
- Washing:
 - Pellet the beads and discard the supernatant.
 - Wash the beads 3-5 times with ice-cold Wash Buffer.
- Elution and Sample Preparation:
 - After the final wash, remove all supernatant.

- Resuspend the beads in 2x Laemmli sample buffer.
- Boil the samples at 95-100°C for 5-10 minutes to elute the proteins and denature them for SDS-PAGE.
- Pellet the beads, and the supernatant containing the immunoprecipitated proteins is ready for Western blot analysis.

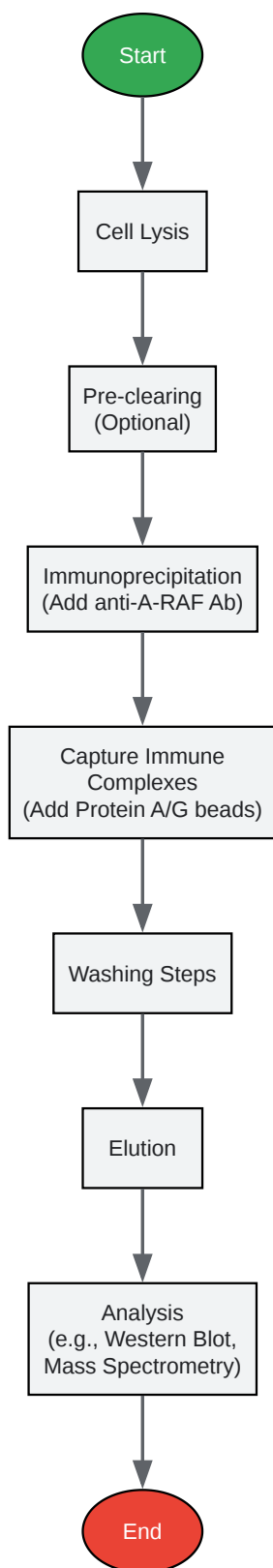

[Click to download full resolution via product page](#)

Need Custom Synthesis?

BenchChem offers custom synthesis for rare earth carbides and specific isotopic labeling.

Email: info@benchchem.com or [Request Quote Online](#).

References

- 1. Inhibitors that stabilize a closed RAF kinase domain conformation induce dimerization - PMC [[pmc.ncbi.nlm.nih.gov](https://pubmed.ncbi.nlm.nih.gov/)]
- 2. Phospho-A-Raf (Ser299) Antibody | Cell Signaling Technology [[cellsignal.com](https://www.cellsignal.com/)]
- 3. A novel phosphorylation site involved in dissociating RAF kinase from the scaffolding protein 14-3-3 and disrupting RAF dimerization - PMC [[pmc.ncbi.nlm.nih.gov](https://pubmed.ncbi.nlm.nih.gov/)]
- To cite this document: BenchChem. [An In-Depth Technical Guide to the Mechanism of Action of A-RAF]. BenchChem, [2026]. [Online PDF]. Available at: [<https://www.benchchem.com/product/b15294726/docs#an-in-depth-technical-guide-to-the-mechanism-of-action-of-a-raf>]

Disclaimer & Data Validity:

The information provided in this document is for Research Use Only (RUO) and is strictly not intended for diagnostic or therapeutic procedures. While BenchChem strives to provide accurate protocols, we make no warranties, express or implied, regarding the fitness of this product for every specific experimental setup.

Technical Support: The protocols provided are for reference purposes. Unsure if this reagent suits your experiment?

Need Industrial/Bulk Grade? [Request Custom Synthesis Quote](#)

BenchChem

Our mission is to be the trusted global source of essential and advanced chemicals, empowering scientists and researchers to drive progress in science and industry.

Contact

Address: 3281 E Guasti Rd

Ontario, CA 91761, United States

Phone: (601) 213-4426

Email: info@benchchem.com

[Contact our Ph.D. Support Team for a compatibility check](#)