

Optimizing solvent selection for BCP-piperazine coupling reactions

Author: BenchChem Technical Support Team. **Date:** May 2026

Compound of Interest

Compound Name: *1-Benzyl-4-bicyclo[1.1.1]pent-1-yl-piperazine*

Cat. No.: *B15293126*

[Get Quote](#)

Technical Support Center: BCP-Piperazine Coupling Optimization

Subject: Solvent & Protocol Optimization for Bicyclo[1.1.1]pentane (BCP) – Piperazine Couplings
Ticket ID: BCP-PIP-OPT-001 Status: Open Assigned Specialist: Senior Application Scientist

Executive Summary

Coupling Bicyclo[1.1.1]pentane (BCP) cores with piperazine moieties is a high-value transformation in medicinal chemistry, often used to improve metabolic stability and solubility compared to phenyl-piperazine analogues.^{[1][2]} However, the unique strain energy of the BCP ring (~65 kcal/mol) and the polarity mismatch between the lipophilic BCP cage and the polar piperazine create specific solvent challenges.

This guide addresses the two primary coupling modes:

- Amide Coupling: BCP-COOH + Piperazine.^[3]
- Buchwald-Hartwig Amination: BCP-Halide + Piperazine.^{[3][4]}

Module 1: Solvent Selection Matrix

User Question: "I typically use DMF for couplings, but my workup is messy. What solvents balance BCP solubility with easier isolation?"

Technical Insight: While dipolar aprotic solvents (DMF, NMP) are excellent for solubilizing zwitterionic BCP amino acids, they complicate aqueous workups due to their high boiling points and water miscibility. For BCP-piperazine systems, 2-Methyltetrahydrofuran (2-MeTHF) is the superior choice. It offers high solubility for the BCP lipophilic core while being immiscible with water, allowing for direct aqueous washes without extraction steps.[3]

Solvent Performance Table

Solvent	Polarity	BCP Solubility	Green Score	Workup Efficiency	Recommended Use
2-MeTHF	Med-High	Excellent	High	Best (Phase separates)	Primary choice for Amide & Pd-Coupling.
DMF/DMAc	High	Excellent	Low	Poor (Requires multiple washes)	Use only if reagents (e.g., HATU) are insoluble in 2-MeTHF.
EtOAc	Medium	Good	High	Good	Good for amide couplings; poor for Pd-catalysis (coord.[3] issues).
CPME	Low-Med	Good	High	Excellent (Low peroxide risk)	Ideal for high-temp Buchwald couplings.
Toluene	Low	High	Med	Good	Standard for Buchwald; poor for Amide coupling salts.[3]

Visual Guide: Solvent Decision Tree

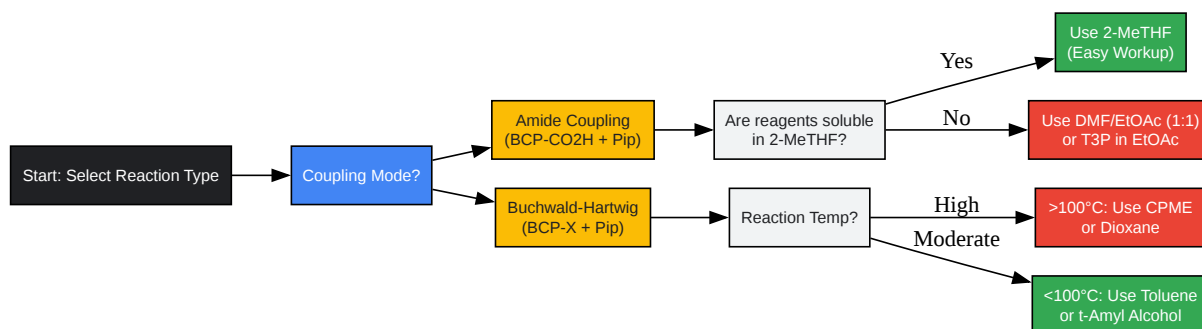

[Click to download full resolution via product page](#)

Caption: Decision logic for selecting the optimal solvent based on reaction type and processing requirements.

Module 2: Amide Coupling Protocols (BCP-COOH)

User Question: "My HATU coupling yields are low (30-40%), and I see significant impurities. How do I fix this?"

Diagnosis:

- Double Addition: Piperazine has two nitrogens.[3][5] If you use free piperazine (not N-Boc protected), you risk forming the BCP-Pip-BCP dimer.
- DMF Decomposition: If heating is required, DMF decomposes to dimethylamine, which competes with piperazine for the BCP activated ester.[3]
- Activation Lag: BCP carboxylic acids are sterically bulky.[3] Fast reagents like HATU may hydrolyze before the amine attacks if the solvent contains trace water.[3]

Optimized Protocol (The "Green" T3P Route): Propylphosphonic anhydride (T3P) is recommended over HATU for BCPs. It is less sensitive to moisture and produces water-soluble byproducts, eliminating the need for column chromatography in many cases.

- Dissolve: 1.0 eq BCP-COOH and 1.1 eq N-Boc-Piperazine in 2-MeTHF (5-10 volumes).
- Base: Add 3.0 eq DIPEA (or N-Methylmorpholine). Cool to 0°C.[3][6]
- Reagent: Add 1.5 eq T3P (50% solution in EtOAc/2-MeTHF) dropwise.
- Reaction: Warm to RT. Stir 2-4 hours.
- Workup: Add water. Separate phases. Wash organic layer with 0.5M NaOH (removes unreacted T3P/acid) and brine.[3]
- Isolation: Evaporate.

Module 3: Buchwald-Hartwig Amination (BCP-Halide)

User Question: "I am trying to couple BCP-Bromide with Piperazine using Pd(OAc)₂, but the catalyst crashes out and the BCP degrades."

Technical Insight: BCP-halides are thermally sensitive.[3][7] Standard Buchwald conditions (100°C+, strong bases like NaOtBu) often cause BCP ring fragmentation or polymerization. Furthermore, Pd(OAc)₂ is a poor precatalyst for this hindered system.[7]

Critical Adjustments:

- Catalyst: Switch to Pd-G3-Precatalysts (e.g., XantPhos-Pd-G3 or RuPhos-Pd-G3). These activate at lower temperatures.[3]
- Base: Use a soluble, milder organic base like DBU or a weak inorganic base like Cs₂CO₃ to prevent BCP decomposition.[3]
- Solvent: t-Amyl alcohol or CPME.[3] These solvents solubilize the catalytic species better than toluene and allow for higher temperatures without pressurization if needed.[3]

Troubleshooting Workflow:

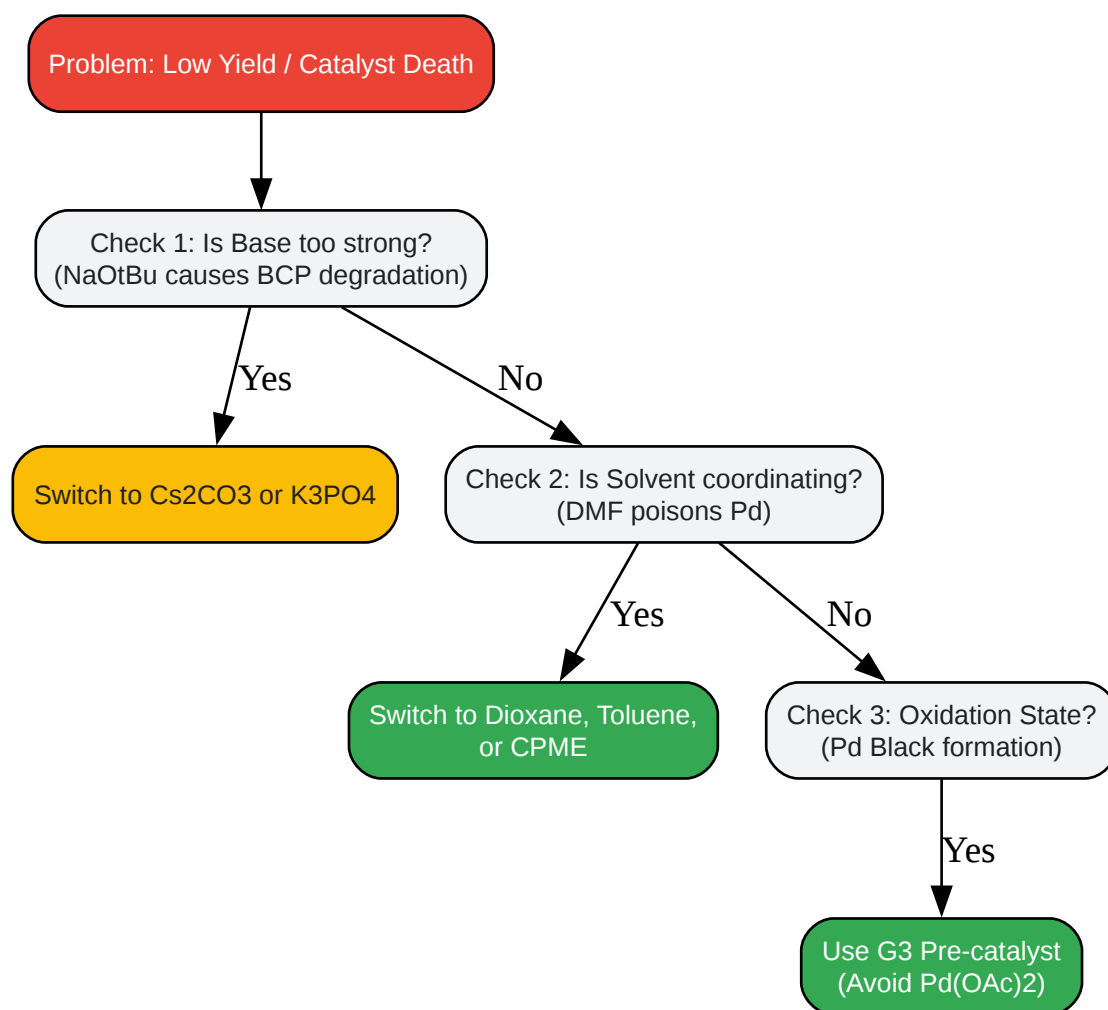

[Click to download full resolution via product page](#)

Caption: Step-by-step troubleshooting for failed Buchwald-Hartwig couplings involving BCPs.

Module 4: FAQ & Specific Scenarios

Q: Can I use water as a co-solvent? A: For Amide coupling, yes.[3] "On-water" conditions using surfactant technology (e.g., TPGS-750-M) are highly effective for BCP-piperazine couplings, often accelerating the reaction due to the hydrophobic effect forcing the lipophilic BCP and piperazine together in micelles.

Q: My product is water-soluble (e.g., deprotected piperazine). How do I extract it? A: If you have removed the Boc group and the product is stuck in the aqueous phase:

- Saturate the aqueous phase with NaCl (salting out).[3]

- Extract with Isopropanol:Chloroform (1:3) or n-Butanol.[3]
- Alternatively, use a resin capture (SCX-2 column): Load the mixture, wash with MeOH, elute product with 2M NH₃ in MeOH.

Q: I see a +18 mass impurity in LCMS. A: This is likely BCP ring opening (hydration) or hydrolysis of the activated ester.[3]

- Cause: Acidic conditions or high temperature in the presence of water.[3]
- Fix: Ensure anhydrous solvents.[3][4] If using Buchwald, lower the temperature and switch to a more active catalyst (e.g., BrettPhos) to compensate for the lower heat.

References

- Green Solvent Selection: Jordan, A., & Sneddon, H. (2019). Development of a Solvent-Reagent Selection Guide for the Formation of Thioesters (Relevant for Amide/Ester logic). Royal Society of Chemistry.[3] [Link](#)
- BCP Bioisosteres:Bicyclo[1.1.1]pentane (BCP) as an sp³ Carbon-rich Bioisostere.[1][3][8] PharmaBlock Whitepaper.[1][3] [Link](#)
- Amide Coupling in 2-MeTHF: Alili, D., et al. (2016). 2-Methyltetrahydrofuran and Ethyl Acetate for Solid-Phase Peptide Synthesis under Green Conditions. ACS Sustainable Chemistry & Engineering.[3][9] [Link](#)
- Buchwald-Hartwig Optimization:Application Notes and Protocols for N-Boc-piperazine Buchwald-Hartwig Amination. BenchChem Technical Guides. [Link](#)
- Piperazine Solubility Data:Piperazine Physicochemical Properties. National Center for Biotechnology Information.[3] PubChem Compound Summary. [Link](#)

Need Custom Synthesis?

BenchChem offers custom synthesis for rare earth carbides and specific isotopic labeling.

Email: info@benchchem.com or [Request Quote Online](#).

Sources

- [1. img01.pharmablock.com](http://img01.pharmablock.com) [img01.pharmablock.com]
- [2. nbinno.com](http://nbinno.com) [nbinno.com]
- [3. backend.orbit.dtu.dk](http://backend.orbit.dtu.dk) [backend.orbit.dtu.dk]
- [4. pdf.benchchem.com](http://pdf.benchchem.com) [pdf.benchchem.com]
- [5. pdf.benchchem.com](http://pdf.benchchem.com) [pdf.benchchem.com]
- [6. Lab Reporter](http://fishersci.co.uk) [fishersci.co.uk]
- [7. reddit.com](http://reddit.com) [reddit.com]
- [8. Development of novel bicyclo\[1.1.1\]pentanes \(BCP\) bioisosteres from bench stable | Postgraduate study | Loughborough University](#) [lboro.ac.uk]
- [9. Molecular Solvents – Replacements for DMF, DMAC, NMP - Wordpress](#) [reagents.acsgcipr.org]
- To cite this document: BenchChem. [Optimizing solvent selection for BCP-piperazine coupling reactions]. BenchChem, [2026]. [Online PDF]. Available at: [<https://www.benchchem.com/product/b15293126/docs#optimizing-solvent-selection-for-bcp-piperazine-coupling-reactions>]

Disclaimer & Data Validity:

The information provided in this document is for Research Use Only (RUO) and is strictly not intended for diagnostic or therapeutic procedures. While BenchChem strives to provide accurate protocols, we make no warranties, express or implied, regarding the fitness of this product for every specific experimental setup.

Technical Support: The protocols provided are for reference purposes. Unsure if this reagent suits your experiment?

Need Industrial/Bulk Grade? [Request Custom Synthesis Quote](#)

BenchChem

Our mission is to be the trusted global source of essential and advanced chemicals, empowering scientists and researchers to drive progress in science and industry.

Contact

Address: 3281 E Guasti Rd

Ontario, CA 91761, United States

Phone: (601) 213-4426

Email: info@benchchem.com

[Contact our Ph.D. Support Team for a compatibility check](#)