

# Application Notes and Protocols for the Analytical Determination of Ulipristal Acetate

**Author:** BenchChem Technical Support Team. **Date:** December 2025

## Compound of Interest

Compound Name: *Ulipristal Diacetate*

Cat. No.: *B15292145*

[Get Quote](#)

## Introduction

Ulipristal acetate is a selective progesterone receptor modulator used for emergency contraception and the treatment of uterine fibroids. Accurate and precise analytical methods are crucial for its quantification in pharmaceutical formulations and biological matrices to ensure safety and efficacy. These application notes provide detailed protocols for the determination of ulipristal acetate using various analytical techniques, including High-Performance Liquid Chromatography (HPLC), Liquid Chromatography-Tandem Mass Spectrometry (LC-MS/MS), and UV-Visible Spectrophotometry.

## I. High-Performance Liquid Chromatography (HPLC) Methods

HPLC is a widely used technique for the routine analysis of ulipristal acetate in bulk drug and pharmaceutical dosage forms. Several stability-indicating RP-HPLC methods have been developed and validated.

### A. Comparative Summary of HPLC Methods

| Parameter                                 | Method 1[1]   | Method 2[2]                          | Method 3[3]                                      | Method 4[4]  |
|---|---|--------------------------------------|--|--|
| Stationary Phase                          | Phenoxneome C18 (150 mm x 4.6 mm, 5 μm)                       | Wondasil C18 (250 mm x 4.6 mm, 5 μm) | Symmetry C18 (250 mm x 4.6 mm, 5 μm)             | xBridge™ C18 (250 mm x 4.6 mm, 5μ)                   |
| Mobile Phase                              | 0.1% Ortho Phosphoric Acid : Acetonitrile (50:50 v/v), pH 4.0 | Acetonitrile : Water (70:30 v/v)     | Phosphate Buffer (pH 4.6) : Methanol (20:80 v/v) | 20 mM Acetate Buffer (pH 3.7) : Methanol (70:30 v/v) |
| Flow Rate                                 | 1.0 mL/min  | 1.0 mL/min                           | 1.0 mL/min                                       | 1.0 mL/min   |
| Detection Wavelength                      | 223 nm  | 302 nm                               | 304 nm   | 309 nm   |
| Retention Time                            | 1.895 min   | Not Specified                        | 1.516 min  | 6.53 min   |
| Linearity Range                           | 20-100 μg/mL  | 22.90-68.70 μg/mL                    | 0.025-30 μg/mL                                   | 10-60 μg/mL  |
| Correlation Coefficient (r <sup>2</sup> ) | 0.999   | 0.9989                               | > 0.999  | 0.98   |
| LOD                                       | Not Specified   | Not Specified                        | 0.020 μg/mL                                      | 0.371 μg/mL  |
| LOQ                                       | Not Specified   | Not Specified                        | 0.061 μg/mL                                      | 1.23 μg/mL   |

## B. Experimental Protocol: Stability-Indicating RP-HPLC Method[1]

This protocol describes a simple, precise, and accurate stability-indicating RP-HPLC method for the estimation of Ulipristal Acetate.

### 1. Materials and Reagents:

- Ulipristal Acetate reference standard
- Acetonitrile (HPLC grade)
- Ortho Phosphoric Acid (AR grade)

- Triethylamine (AR grade)

- Water (HPLC grade)

## 2. Chromatographic Conditions:

- Instrument: HPLC system with UV-Vis detector
- Column: Phenoxneome C18 (150 mm x 4.6 mm, 5  $\mu$ m)
- Mobile Phase: A 50:50 (v/v) mixture of 0.1% ortho phosphoric acid (pH adjusted to 4.0 with triethylamine) and acetonitrile.
- Flow Rate: 1.0 mL/min
- Injection Volume: 20  $\mu$ L
- Detector Wavelength: 223 nm
- Column Temperature: Ambient

## 3. Preparation of Solutions:

- Standard Stock Solution: Accurately weigh and dissolve 10 mg of Ulipristal Acetate in 10 mL of mobile phase to obtain a concentration of 1000  $\mu$ g/mL.
- Working Standard Solutions: From the stock solution, prepare a series of dilutions ranging from 20-100  $\mu$ g/mL with the mobile phase.

## 4. Procedure:

- Equilibrate the HPLC system with the mobile phase for at least 30 minutes.
- Inject 20  $\mu$ L of each working standard solution and record the chromatograms.
- Plot a calibration curve of peak area versus concentration.
- For the analysis of a sample, prepare the sample solution in the mobile phase to a concentration within the linearity range and inject it into the system.

- Determine the concentration of Ulipristal Acetate in the sample from the calibration curve.

### C. Workflow for HPLC Analysis



[Click to download full resolution via product page](#)

Caption: General workflow for the HPLC analysis of Ulipristal Acetate.

## II. Liquid Chromatography-Tandem Mass Spectrometry (LC-MS/MS) Methods

LC-MS/MS provides high sensitivity and selectivity, making it suitable for the quantification of ulipristal acetate in biological matrices such as human plasma and serum.

### A. Comparative Summary of LC-MS/MS Methods

| Parameter            | Method 1[5]   | Method 2[6][7]  | Method 3[8]                             |
|----------------------|---|---|---|
| Matrix               | Human Plasma  | Human Serum   | Human Plasma                            |
| Sample Preparation   | Protein Precipitation (Methanol)  | Liquid-Liquid Extraction (Hexane:Dichloromethane)             | Protein Precipitation (Methanol)        |
| Stationary Phase     | Kinetex EVO C18 (2.1 x 50 mm, 2.6 µm)   | Kinetex C18 (50 x 2.1 mm, 1.7 µm)                             | ACE Excel 3 C18-PFP                     |
| Mobile Phase         | Methanol and Water with 2 mM Ammonium Acetate and 0.3% Formic Acid (Gradient) | Water and Acetonitrile, both with 0.1% Formic Acid (Gradient) | Gradient Elution                        |
| Flow Rate            | 0.3 mL/min  | 0.2 mL/min  | Not Specified                           |
| Ionization Mode      | Positive Electrospray Ionization (ESI+)                                       | Positive Electrospray Ionization (ESI+)                       | Positive Electrospray Ionization (ESI+) |
| MRM Transition (UPA) | m/z 476.2 → 134.1   | Not Specified   | m/z 476.2 → 134.1                       |
| MRM Transition (IS)  | m/z 479.3 → 416.2 (UPA-d3)  | Not Specified   | m/z 479.3 → 416.2 (UPA-d3)              |
| Linearity Range      | 0.300-300 ng/mL   | 0.1-250 ng/mL   | 0.0500-100 ng/mL                        |
| LOD                  | Not Specified   | 0.025 ng/mL   | Not Specified                           |
| LOQ                  | 0.300 ng/mL   | 0.100 ng/mL   | 0.0500 ng/mL                            |

## B. Experimental Protocol: LC-MS/MS Method for Human Plasma[5]

This protocol details a sensitive and reliable method for the quantification of ulipristal acetate in human plasma.

### 1. Materials and Reagents:

- Ulipristal Acetate reference standard

- Ulipristal Acetate-d3 (Internal Standard, IS)
- Methanol (LC-MS grade)
- Ammonium Acetate (LC-MS grade)
- Formic Acid (LC-MS grade)
- Water (LC-MS grade)
- Human Plasma (blank)

## 2. Chromatographic and Mass Spectrometric Conditions:

- Instrument: LC-MS/MS system
- Column: Kinetex EVO C18 (2.1 x 50 mm, 2.6  $\mu$ m)
- Mobile Phase A: Water with 2 mM ammonium acetate and 0.3% formic acid
- Mobile Phase B: Methanol
- Flow Rate: 0.3 mL/min
- Gradient Program: Optimized for separation
- Ion Source: Electrospray Ionization (ESI), positive mode
- Scan Type: Multiple Reaction Monitoring (MRM)
- MRM Transitions:
  - Ulipristal Acetate: m/z 476.2  $\rightarrow$  134.1
  - Ulipristal Acetate-d3 (IS): m/z 479.3  $\rightarrow$  416.2

## 3. Preparation of Solutions:

- Stock Solutions: Prepare individual stock solutions of Ulipristal Acetate and the IS in methanol.
- Working Solutions: Prepare serial dilutions of Ulipristal Acetate and a working solution of the IS in methanol:water (50:50).
- Calibration Standards and Quality Controls (QCs): Spike blank human plasma with the appropriate working solutions to prepare calibration standards and QCs.

#### 4. Sample Preparation (Protein Precipitation):

- To 100  $\mu\text{L}$  of plasma sample (blank, calibration standard, QC, or unknown), add 20  $\mu\text{L}$  of IS working solution and vortex.
- Add 300  $\mu\text{L}$  of methanol, vortex for 1 minute.
- Centrifuge at 13,000 rpm for 10 minutes.
- Transfer the supernatant to a clean tube and evaporate to dryness under a stream of nitrogen.
- Reconstitute the residue in 100  $\mu\text{L}$  of mobile phase A:B (50:50) and inject into the LC-MS/MS system.

#### C. Workflow for LC-MS/MS Analysis



[Click to download full resolution via product page](#)

Caption: Workflow for the LC-MS/MS analysis of Ulipristal Acetate in plasma.

## III. UV-Visible Spectrophotometric Methods

Spectrophotometric methods offer a simpler and more cost-effective alternative for the determination of ulipristal acetate, particularly in bulk and pharmaceutical formulations.

## A. Comparative Summary of Spectrophotometric Methods

| Parameter                   | Method 1[9][10]                                     | Method 2[11][12]             |
|-----------------------------|---|------------------------------|
| Principle                   | Ion-pair complex formation with Naphthol Blue Black | Oxidative coupling with MBTH |
| Solvent                     | Chloroform  | Acidic Medium                |
| $\lambda_{\max}$            | 640 nm  | 609 nm                       |
| Linearity Range             | 2.50–15.00 $\mu\text{g/mL}$                         | 6.25-37.50 $\mu\text{g/mL}$  |
| Correlation Coefficient (r) | > 0.999   | > 0.999                      |
| % Recovery                  | 99.80–100.72%                                       | Not Specified                |
| Precision (%RSD)            | 0.007–0.560   | Low                          |

## B. Experimental Protocol: Ion-Pair Spectrophotometric Method[9][10]

This protocol is based on the formation of an ion-association complex between ulipristal acetate and the acid dye, naphthol blue black.

## 1. Materials and Reagents:

- Ulipristal Acetate reference standard
- Naphthol Blue Black solution (0.2% w/v in distilled water)
- Hydrochloric Acid (0.1 N)
- Chloroform (AR grade)
- Methanol (AR grade)

## 2. Instrumentation:

- UV-Visible Spectrophotometer

## 3. Preparation of Solutions:



- Standard Stock Solution: Accurately weigh 50 mg of Ulipristal Acetate and dissolve in 100 mL of methanol to get a concentration of 500 µg/mL.
- Working Standard Solutions: Prepare a series of dilutions from the stock solution in the range of 2.50–15.00 µg/mL.

#### 4. Procedure:

- To a series of 10 mL volumetric flasks, add aliquots of the working standard solutions.
- Add 1 mL of 0.1 N HCl to each flask.
- Add 1 mL of Naphthol Blue Black solution and mix well.
- Extract the formed colored complex with 5 mL of chloroform by shaking for 2 minutes.
- Allow the layers to separate and collect the chloroform layer.
- Measure the absorbance of the chloroform layer at 640 nm against a reagent blank.
- Plot a calibration curve of absorbance versus concentration.

#### C. Signaling Pathway for Complex Formation

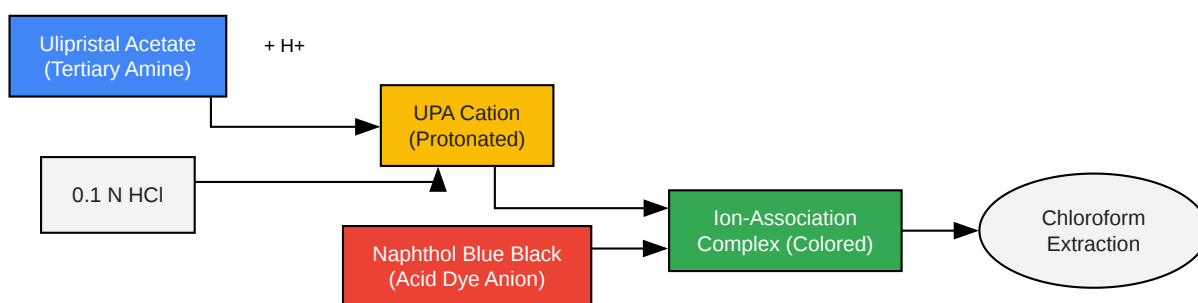

[Click to download full resolution via product page](#)

Caption: Reaction pathway for the spectrophotometric detection of Ulipristal Acetate.

**Need Custom Synthesis?**

BenchChem offers custom synthesis for rare earth carbides and specific isotopic labeling.

Email: [info@benchchem.com](mailto:info@benchchem.com) or [Request Quote Online](#).

## References

- 1. [ijraps.in \[ijraps.in\]](#)
- 2. [researchgate.net \[researchgate.net\]](#)
- 3. [researchgate.net \[researchgate.net\]](#)
- 4. [researchgate.net \[researchgate.net\]](#)
- 5. A simplified and reliable LC-tandem mass spectrometry method for determination of ulipristal acetate in human plasma and its application to a pharmacokinetic study in healthy Chinese volunteers - PubMed [[pubmed.ncbi.nlm.nih.gov](#)]
- 6. A UPLC-MS/MS method for the quantitation of Ulipristal acetate in human serum - PubMed [[pubmed.ncbi.nlm.nih.gov](#)]
- 7. [2024.sci-hub.se \[2024.sci-hub.se\]](#)
- 8. A novel LC-MS/MS method for the quantification of ulipristal acetate in human plasma: Application to a pharmacokinetic study in healthy Chinese female subjects - PubMed [[pubmed.ncbi.nlm.nih.gov](#)]
- 9. [rjptonline.org \[rjptonline.org\]](#)
- 10. Extractive Spectrophotometric Determination of Ulipristal Acetate using Naphthol Blue Black, [viXra.org e-Print archive, viXra:1905.0334 \[rxiv.org\]](#)
- 11. [researchgate.net \[researchgate.net\]](#)
- 12. [scribd.com \[scribd.com\]](#)
- To cite this document: BenchChem. [Application Notes and Protocols for the Analytical Determination of Ulipristal Acetate]. BenchChem, [2025]. [Online PDF]. Available at: [<https://www.benchchem.com/product/b15292145#analytical-methods-for-ulipristal-diacetate-detection>]

---

**Disclaimer & Data Validity:**

The information provided in this document is for Research Use Only (RUO) and is strictly not intended for diagnostic or therapeutic procedures. While BenchChem strives to provide accurate protocols, we make no warranties, express or implied, regarding the fitness of this product for every specific experimental setup.

**Technical Support:** The protocols provided are for reference purposes. Unsure if this reagent suits your experiment? [[Contact our Ph.D. Support Team for a compatibility check](#)]

**Need Industrial/Bulk Grade?** [Request Custom Synthesis Quote](#)

## BenchChem

Our mission is to be the trusted global source of essential and advanced chemicals, empowering scientists and researchers to drive progress in science and industry.

### Contact

Address: 3281 E Guasti Rd  
Ontario, CA 91761, United States  
Phone: (601) 213-4426  
Email: [info@benchchem.com](mailto:info@benchchem.com)