

Technical Support Center: Minimizing Off-Target Effects of 2-Chloroadenosine

Author: BenchChem Technical Support Team. **Date:** May 2026

Compound of Interest

Compound Name: 2-Cyanomethylthioadenosine

Cat. No.: B15291871

[Get Quote](#)

Welcome to the technical support center for researchers utilizing 2-Chloroadenosine (2-CADO), a metabolically stable adenosine analogue. This resource provides guidance on understanding and mitigating potential off-target effects to ensure the accurate interpretation of your experimental results. As **2-Cyanomethylthioadenosine** is not extensively characterized in scientific literature, we will use the well-documented analogue, 2-Chloroadenosine, as a representative compound to address common challenges.

Frequently Asked Questions (FAQs)

Q1: What are the primary mechanisms of action for 2-Chloroadenosine (2-CADO)?

A1: 2-Chloroadenosine exerts its biological effects through two primary mechanisms:

- Adenosine Receptor Agonism: 2-CADO is a non-selective agonist for adenosine receptors (A1, A2A, A2B, and A3), which are G protein-coupled receptors that modulate various intracellular signaling pathways.[1][2] A1 and A3 receptors are typically coupled to Gi proteins, leading to an inhibition of adenylyl cyclase and a decrease in cyclic AMP (cAMP) levels.[3] Conversely, A2A and A2B receptors are coupled to Gs proteins, stimulating adenylyl cyclase and increasing cAMP levels.[3]

- Intracellular Metabolism: 2-CADO can be transported into the cell and subsequently phosphorylated by adenosine kinase to form 2-chloro-ATP.[4][5] This metabolite can inhibit DNA synthesis, leading to cell cycle arrest in the S-phase and induction of apoptosis.[4][6]

Q2: What are the potential off-target effects of 2-CADO?

A2: Off-target effects of 2-CADO can arise from several sources:

- Unintended Adenosine Receptor Subtype Activation: Due to its non-selective nature, 2-CADO can activate multiple adenosine receptor subtypes simultaneously, which may not be the intended target for your specific research question. This can lead to a complex downstream signaling cascade that might obscure the effects of activating a particular receptor.
- Effects of Intracellular Metabolism: The cytotoxic effects resulting from the intracellular conversion of 2-CADO to 2-chloro-ATP can be considered off-target if the intended focus of the experiment is on adenosine receptor signaling.[4][5][7] This is particularly relevant in studies on cell proliferation and viability.
- Unknown Kinase Inhibition: Like many small molecules, 2-CADO could potentially interact with and inhibit the activity of various protein kinases, independent of its action on adenosine receptors. Identifying these interactions is crucial for a complete understanding of its cellular effects.

Q3: How can I differentiate between adenosine receptor-mediated effects and those caused by intracellular metabolism?

A3: Several experimental strategies can be employed:

- Use of Adenosine Receptor Antagonists: Co-treatment of your cells with a selective antagonist for the adenosine receptor subtype you believe to be mediating the observed effect can help to confirm this. If the effect is blocked by the antagonist, it is likely receptor-mediated.
- Inhibition of Adenosine Kinase: To investigate the role of intracellular metabolism, you can use an adenosine kinase inhibitor, such as 5-iodotubercidin.[5] If the observed effect is

diminished in the presence of the inhibitor, it suggests that the phosphorylation of 2-CADO to 2-chloro-ATP is a key step.[5][7]

- Use of Non-Metabolizable Analogues: Employing adenosine analogues that are not substrates for adenosine kinase can help to isolate receptor-mediated effects.

Troubleshooting Guides

Issue 1: Unexpected cytotoxicity observed in my cell line upon treatment with 2-CADO.

- Possible Cause: The cytotoxicity may be due to the intracellular conversion of 2-CADO to 2-chloro-ATP, leading to inhibition of DNA synthesis and apoptosis, rather than an adenosine receptor-mediated effect.[4][5]
- Troubleshooting Steps:
 - Perform a dose-response curve and time-course experiment: This will help to determine the concentration and duration at which cytotoxicity becomes significant.
 - Co-treat with an adenosine kinase inhibitor: As mentioned in the FAQs, using an inhibitor like 5-iodotubercidin can block the conversion to 2-chloro-ATP.[5] A reduction in cytotoxicity would support this off-target mechanism.
 - Assess markers of apoptosis and DNA damage: Use techniques like TUNEL staining or Western blotting for cleaved PARP and phosphorylated H2A.X to confirm if apoptosis and DNA damage are occurring.
 - Consider a different adenosine receptor agonist: If your goal is to study receptor signaling without inducing cytotoxicity, you may need to screen for other agonists that are less prone to intracellular phosphorylation.

Issue 2: Inconsistent or unexpected results in downstream signaling analysis (e.g., cAMP levels, protein phosphorylation).

- Possible Cause: The non-selective nature of 2-CADO is likely activating multiple adenosine receptor subtypes, leading to conflicting downstream signals. For instance, activation of both

Gi-coupled (A1/A3) and Gs-coupled (A2A/A2B) receptors can have opposing effects on adenylyl cyclase activity.[3]

- Troubleshooting Steps:
 - Profile adenosine receptor expression: Determine which adenosine receptor subtypes are expressed in your experimental system (e.g., via qPCR or Western blotting). This will help you to anticipate the likely targets of 2-CADO.
 - Use selective antagonists: To isolate the signaling pathway of interest, use selective antagonists to block the other adenosine receptor subtypes.
 - Employ selective agonists: If possible, use agonists that are highly selective for the specific adenosine receptor subtype you are studying.
 - Perform a kinome-wide screen: To identify potential off-target kinase interactions that might be affecting your signaling pathways.

Quantitative Data

Table 1: Binding Affinities (K_i) of 2-Chloroadenosine for Human Adenosine Receptors

| Receptor Subtype | K _i (nM) |
|------------------|---------------------|
| A1 | 300[8][9] |
| A2A | 80[8][9] |
| A3 | 1900[8][9] |

Table 2: IC₅₀ Values of 2-Chloroadenosine in Various Cell Lines

| Cell Line | IC50 (μM) | Assay |
|-----------|--|-----------------------------|
| CCRF-CEM | 10[10] | Cytotoxicity Assay |
| HEp-2 | 3[10] | Cytotoxicity Assay |
| PC3 | Not explicitly stated, but effects seen at 50 μM [10] | Apoptosis/Cell Cycle Arrest |
| EHEB | Effects seen at 10-50 μM [10] | Apoptosis |

Experimental Protocols

Protocol 1: Cellular Thermal Shift Assay (CETSA) to Confirm Target Engagement

This protocol is designed to verify the direct binding of 2-CADO to a target protein (e.g., an adenosine receptor or a potential off-target kinase) within intact cells. The principle is that ligand binding stabilizes the target protein, increasing its resistance to thermal denaturation.[11]

Materials:

- Cell culture reagents
- 2-Chloroadenosine
- DMSO (vehicle control)
- PBS with protease inhibitors
- Lysis buffer
- Reagents for Western blotting (primary and secondary antibodies)

Procedure:

- Cell Treatment: Treat one population of cells with 2-CADO at a desired concentration and another with DMSO for 1-2 hours.

- Heating: Aliquot the treated cell suspensions into PCR tubes and heat them across a range of temperatures (e.g., 40-70°C) for 3 minutes. Include an unheated control.[11]
- Lysis: Lyse the cells by freeze-thaw cycles.[11]
- Separation: Centrifuge the lysates to pellet the aggregated proteins.
- Analysis: Collect the supernatant (soluble protein fraction) and analyze the amount of the target protein by Western blotting.
- Data Interpretation: A shift in the melting curve to a higher temperature in the presence of 2-CADO indicates direct binding to the target protein.

Protocol 2: Kinome Profiling to Identify Off-Target Kinase Interactions

This protocol provides a general workflow for screening 2-CADO against a panel of kinases to identify potential off-target interactions. Commercial services are available that offer comprehensive kinase profiling.

General Workflow:

- Compound Preparation: Prepare 2-CADO at a specified concentration (e.g., 10 μ M).
- Kinase Reactions: The compound is incubated with a panel of purified kinases in the presence of ATP and a substrate.
- Activity Measurement: Kinase activity is measured, typically by quantifying substrate phosphorylation.
- Data Analysis: The percentage of inhibition of each kinase by 2-CADO is calculated relative to a DMSO control. "Hits" are identified as kinases that are significantly inhibited.

Protocol 3: Cell Viability (MTT/MTS) Assay

This protocol is used to assess the cytotoxic effects of 2-CADO.

Materials:

- 96-well plates
- Cell culture medium
- 2-Chloroadenosine
- MTT or MTS reagent
- Solubilization solution (for MTT)
- Microplate reader

Procedure (MTS Assay):

- Cell Seeding: Seed cells in a 96-well plate and allow them to adhere overnight.[12]
- Compound Treatment: Treat cells with a serial dilution of 2-CADO for the desired duration (e.g., 24, 48, 72 hours).[12]
- MTS Addition: Add MTS reagent to each well and incubate for 1-4 hours.[12]
- Absorbance Reading: Measure the absorbance at 490-500 nm.[12]
- Data Analysis: Calculate the percentage of cell viability relative to the vehicle-treated control and determine the IC50 value.

Visualizations

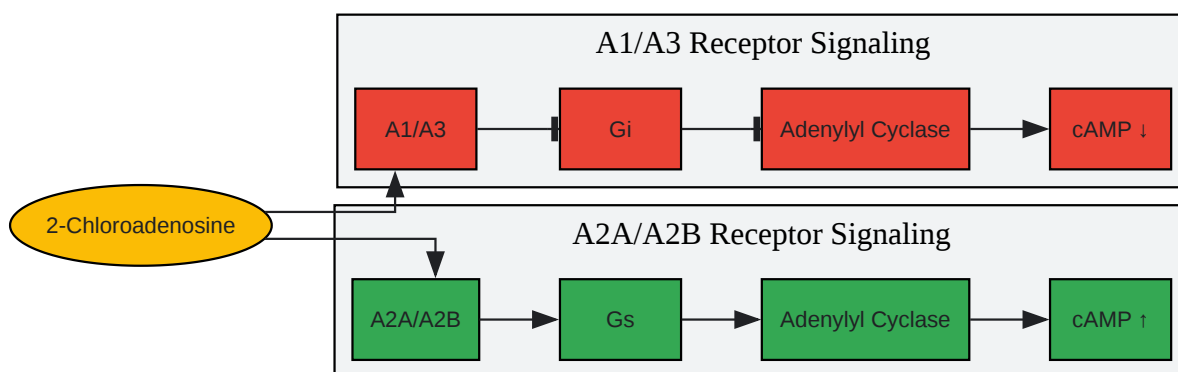

[Click to download full resolution via product page](#)

Caption: Adenosine Receptor Signaling Pathways Activated by 2-Chloroadenosine.

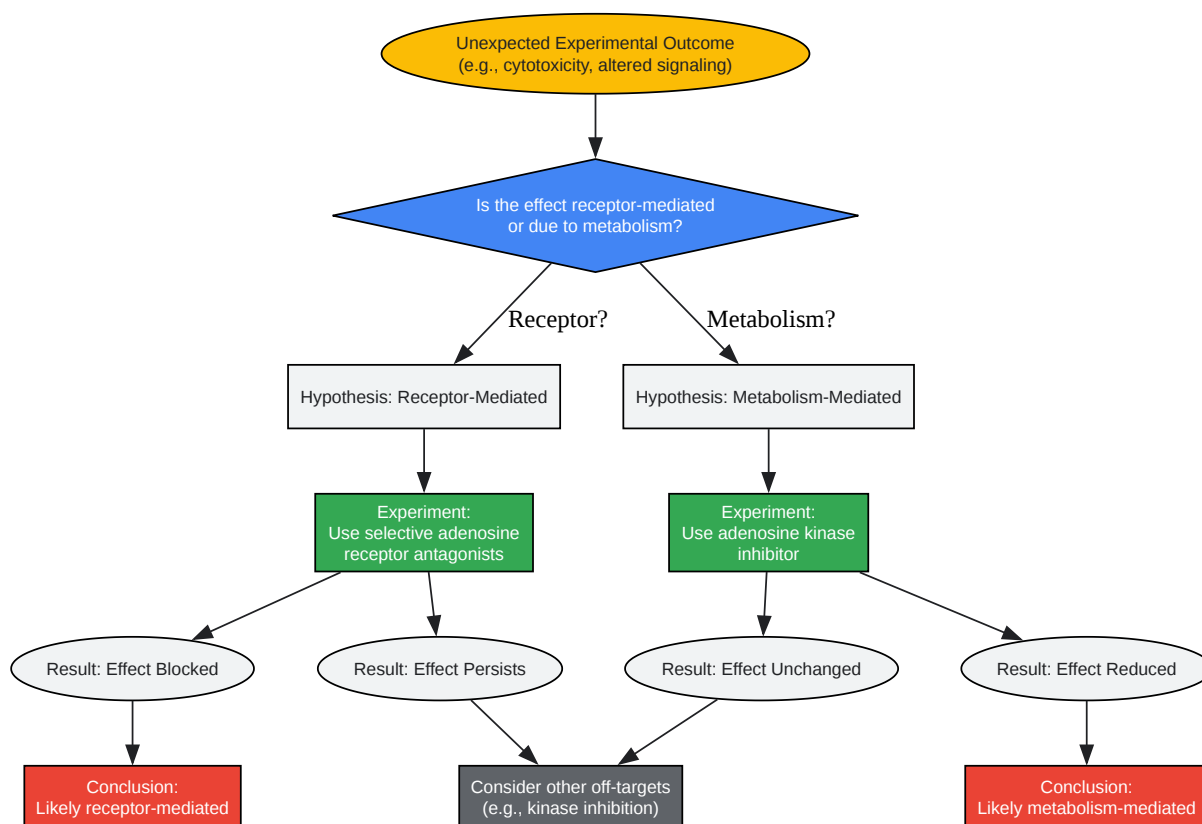

[Click to download full resolution via product page](#)

Caption: Troubleshooting Workflow for 2-Chloroadenosine Off-Target Effects.

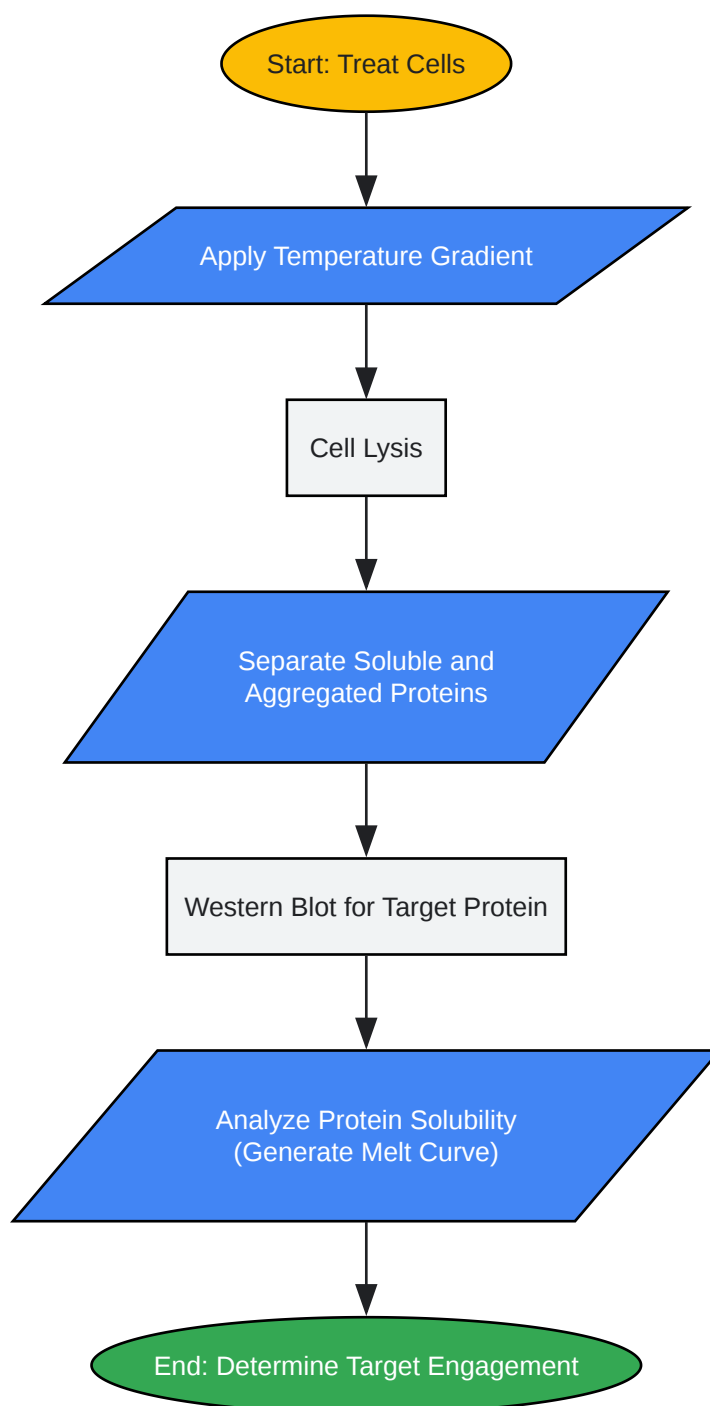

[Click to download full resolution via product page](#)

Caption: Experimental Workflow for the Cellular Thermal Shift Assay (CETSA).

Need Custom Synthesis?

BenchChem offers custom synthesis for rare earth carbides and specific isotopic labeling.

Email: info@benchchem.com or [Request Quote Online](#).

References

- 1. Adenosine receptors and second messenger signaling pathways in rat cardiac fibroblasts - PMC [pubmed.ncbi.nlm.nih.gov]
- 2. Adenosine Receptors: Expression, Function and Regulation - PMC [pubmed.ncbi.nlm.nih.gov]
- 3. [researchgate.net](https://www.researchgate.net) [[researchgate.net](https://www.researchgate.net)]
- 4. Mechanism of 2-chloroadenosine toxicity to PC3 cell line - PubMed [pubmed.ncbi.nlm.nih.gov]
- 5. Mechanisms of cell death induced by 2-chloroadenosine in leukemic B-cells - PubMed [pubmed.ncbi.nlm.nih.gov]
- 6. 2-Chloroadenosine and human prostate cancer cells - PubMed [pubmed.ncbi.nlm.nih.gov]
- 7. Adenosine- and 2-chloro-adenosine-induced cytopathic effects on myoblastic cells and myotubes: involvement of different intracellular mechanisms - PubMed [pubmed.ncbi.nlm.nih.gov]
- 8. dev.usbio.net [dev.usbio.net]
- 9. [caymanchem.com](https://www.caymanchem.com) [[caymanchem.com](https://www.caymanchem.com)]
- 10. [medchemexpress.com](https://www.medchemexpress.com) [[medchemexpress.com](https://www.medchemexpress.com)]
- 11. [benchchem.com](https://www.benchchem.com) [[benchchem.com](https://www.benchchem.com)]
- 12. [benchchem.com](https://www.benchchem.com) [[benchchem.com](https://www.benchchem.com)]
- To cite this document: BenchChem. [Technical Support Center: Minimizing Off-Target Effects of 2-Chloroadenosine]. BenchChem, [2026]. [Online PDF]. Available at: [<https://www.benchchem.com/product/b15291871/docs#technical-support-center-minimizing-off-target-effects-of-2-chloroadenosine>]

Disclaimer & Data Validity:

The information provided in this document is for Research Use Only (RUO) and is strictly not intended for diagnostic or therapeutic procedures. While BenchChem strives to provide accurate protocols, we make no warranties, express or implied, regarding the fitness of this product for every specific experimental setup.

Technical Support: The protocols provided are for reference purposes. Unsure if this reagent suits your experiment?

Need Industrial/Bulk Grade? [Request Custom Synthesis Quote](#)

BenchChem

Our mission is to be the trusted global source of essential and advanced chemicals, empowering scientists and researchers to drive progress in science and industry.

Contact

Address: 3281 E Guasti Rd
Ontario, CA 91761, United States
Phone: (601) 213-4426
Email: info@benchchem.com

[Contact our Ph.D. Support Team for a compatibility check](#)