

Technical Support Center: BKM-570 Studies & Cell Culture Contamination

Author: BenchChem Technical Support Team. **Date:** April 2026

Compound of Interest

Compound Name: *BKM-570*
Cat. No.: *B15291636*

[Get Quote](#)

This technical support center provides troubleshooting guides and frequently asked questions (FAQs) to assist researchers, scientists, and drug development professionals in preventing and managing cell culture contamination during studies with **BKM-570**.

Frequently Asked Questions (FAQs)

Q1: What is **BKM-570** and what is its mechanism of action?

A1: **BKM-570** is a nonpeptide antagonist of the bradykinin receptor.[1] It has demonstrated cytotoxic effects in various cancer cell lines, including ovarian cancer, by downregulating genes involved in basic cellular mechanisms like cell growth, metabolism, and signal transduction.[1] It is important to distinguish **BKM-570** from BKM120 (Buparlisib), which is a pan-PI3K inhibitor. While both have been investigated as potential anti-cancer agents, they target different signaling pathways.

Q2: What are the most common types of contamination in cell culture?

A2: Cell culture contaminants are broadly categorized as biological or chemical.[2]

- Biological contaminants include bacteria, mycoplasma, yeast, fungi (molds), and viruses.[2][3][4] Cross-contamination with other cell lines is also a significant issue.[4]
- Chemical contaminants can include impurities in media, sera, and water, as well as endotoxins, plasticizers, and detergents.[2]

Q3: How can I detect contamination in my cell cultures?

A3: Early detection is crucial for managing contamination. Common detection methods include:

- **Visual Inspection:** Regularly check for changes in the culture medium's color or turbidity. Bacterial contamination often causes a sudden drop in pH (yellowing of phenol red-containing medium) and cloudiness.[2][5] Fungal contamination may appear as filamentous structures or turbidity.[6]
- **Microscopy:** Use a light microscope to look for bacteria (small, motile particles), yeast (budding, oval-shaped cells), or fungi (filamentous hyphae).[5][6]
- **Mycoplasma Testing:** Mycoplasma is not visible under a standard light microscope and requires specific detection methods like PCR, ELISA, or fluorescent staining (e.g., Hoechst 33258).[5][7] Routine testing for mycoplasma is highly recommended.
- **pH Monitoring:** A sudden and significant change in the pH of the culture medium can be an indicator of microbial contamination.[5]

Troubleshooting Guide: Contamination Events

This guide provides a systematic approach to identifying and resolving contamination issues in your **BKM-570** cell culture experiments.

Problem 1: Sudden turbidity and/or pH change in the culture medium.

- **Possible Cause:** Bacterial or yeast contamination.[2][5]
- **Troubleshooting Steps:**
 - Immediately quarantine the suspected culture(s) to prevent cross-contamination.[8]

- Examine the culture under a phase-contrast microscope at high magnification to identify bacteria (often appearing as small, shimmering particles) or yeast (oval, budding cells).[5]
- If contamination is confirmed, discard the contaminated culture(s) and decontaminate the biosafety cabinet and incubator.[6][9]
- Review your aseptic technique. Ensure proper handwashing, gloving, and sterilization of all equipment and reagents.[8][10]
- Check all reagents (media, serum, supplements) for contamination. If possible, filter-sterilize them using a 0.22 μm filter.[8]

Problem 2: Fuzzy, filamentous growth in the culture vessel.

- Possible Cause: Fungal (mold) contamination.[3][6]
- Troubleshooting Steps:
 - Isolate the contaminated flask or plate immediately.
 - Visually inspect and confirm the presence of mycelia or spores under a microscope.[6]
 - Discard all contaminated cultures. Fungal spores can easily spread through the air.[3]
 - Thoroughly clean and disinfect the incubator, biosafety cabinet, and surrounding areas. Consider using a fungicide.
 - Review laboratory practices. Ensure proper cleaning protocols are in place and that sources of airborne spores (e.g., cardboard boxes in the lab) are minimized.[11]

Problem 3: Cells are growing poorly, have an altered morphology, or show reduced viability, but the medium appears clear.

- Possible Cause: Mycoplasma contamination or chemical contamination.[9]

- Troubleshooting Steps:
 - For suspected Mycoplasma:
 - Quarantine the cell line.
 - Perform a specific mycoplasma detection test (PCR, fluorescent staining, or ELISA).[7]
 - If positive, discard the culture. Attempting to eliminate mycoplasma with antibiotics can be difficult and may not be completely effective.
 - Test all other cell lines in the laboratory for mycoplasma.
 - For suspected Chemical Contamination:
 - Review the preparation of all media and solutions. Ensure high-purity, cell culture-grade water and reagents were used.[12]
 - Consider potential sources of leachables from plasticware or residual detergents on glassware.[4]
 - Test a fresh batch of media and reagents with a new, uncontaminated vial of cells.

Data Presentation

Table 1: Common Types of Cell Culture Contamination and Their Indicators

Contaminant Type	Visual Indicator (Macroscopic)	Microscopic Appearance	Effect on Culture
Bacteria	Sudden turbidity, rapid pH drop (yellow medium)[2]	Small, motile rod-shaped or cocci particles[5]	Rapid cell death[9]
Yeast	Turbidity, potential pH change (yellow medium)[6]	Oval or round, often budding, single cells[6]	Slower cell growth, eventual cell death
Fungi (Mold)	Filamentous growth, visible colonies, may have colored spores[6]	Thin, thread-like hyphae and spore clusters[6]	Entanglement of cells, release of toxic byproducts
Mycoplasma	No visible change in medium clarity[9]	Not visible with a standard light microscope[3]	Altered cell metabolism, growth, and gene expression[5][9]
Chemical	Typically no visible change	No visible organisms	Reduced cell growth, altered morphology, cytotoxicity[4]

Table 2: Preventive Measures for Cell Culture Contamination

Preventive Measure	Key Actions
Aseptic Technique	Work in a certified Class II biosafety cabinet. Minimize movement and talking.[10][13] Spray gloves and items with 70% ethanol before placing them in the hood.[10]
Sterile Reagents & Media	Use certified, pre-tested media, sera, and supplements from reputable suppliers.[6] Filter-sterilize all prepared solutions with a 0.2 µm filter (0.1 µm for mycoplasma removal).[13]
Clean Environment	Regularly clean and disinfect incubators, water baths, and work surfaces.[6][13] Keep the cell culture area free of clutter and unnecessary items.[14]
Quarantine & Testing	Quarantine all new cell lines until they are tested and confirmed to be free of contamination, especially mycoplasma.[4][8]
Proper Storage	Store media and reagents according to the manufacturer's instructions to prevent degradation and contamination.[12]
Avoid Antibiotics	Avoid the routine use of antibiotics, as this can mask low-level contamination and lead to the development of resistant strains.[13][14]

Experimental Protocols

Protocol 1: Routine Mycoplasma Detection by PCR

- **Sample Collection:** Collect 1 ml of spent culture medium from a 70-80% confluent cell culture that has been growing without antibiotics for at least 3 passages.
- **DNA Extraction:** Use a commercial DNA extraction kit suitable for cell culture supernatants to isolate microbial DNA.
- **PCR Amplification:**

- Prepare a PCR master mix containing a DNA polymerase, dNTPs, and primers specific for conserved regions of the mycoplasma 16S rRNA gene.
- Include a positive control (mycoplasma DNA) and a negative control (sterile water) in the PCR run.
- Perform PCR with appropriate cycling conditions (annealing temperature and extension time will depend on the specific primers and polymerase used).
- Gel Electrophoresis:
 - Run the PCR products on a 1.5% agarose gel stained with a DNA intercalating dye.
 - Visualize the DNA bands under UV light. The presence of a band of the expected size in the sample lane indicates mycoplasma contamination.

Protocol 2: Aseptic Technique for Handling BKM-570 and Cell Cultures

- Preparation:
 - Don a clean lab coat and gloves.[15]
 - Thoroughly wipe down the interior surfaces of the biosafety cabinet with 70% ethanol before and after each use.[13]
 - Place all necessary sterile materials (pipettes, flasks, media, **BKM-570** stock solution) inside the cabinet, ensuring they are arranged to minimize reaching over open containers. [13]
- Handling Reagents:
 - Before opening, wipe the outside of all bottles and containers with 70% ethanol.
 - Do not leave bottles or flasks open for extended periods.
 - Use a fresh sterile pipette for each reagent and cell line to prevent cross-contamination. [10]

- Cell Manipulation:
 - Perform all cell manipulations (e.g., passaging, adding **BKM-570**) in the center of the biosafety cabinet.[\[15\]](#)
 - After use, securely cap all containers.
- Incubation:
 - Wipe down flasks or plates with 70% ethanol before placing them in the incubator to prevent the introduction of contaminants.[\[15\]](#)
- Waste Disposal:
 - Collect all liquid and solid waste in appropriate biohazard containers within the biosafety cabinet.
 - Decontaminate all waste before disposal.

Visualizations

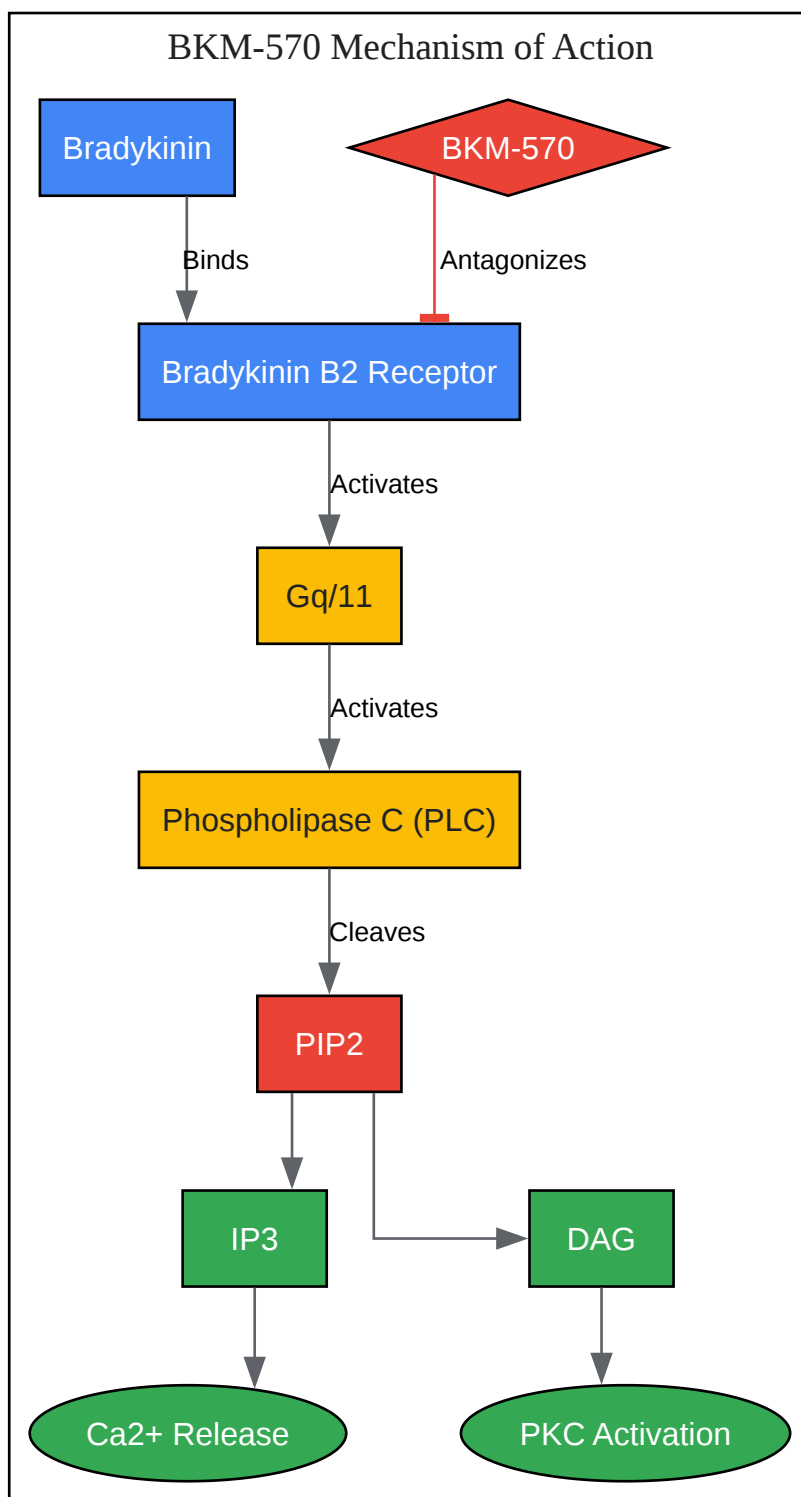

[Click to download full resolution via product page](#)

Caption: **BKM-570** acts as an antagonist to the Bradykinin B2 Receptor.

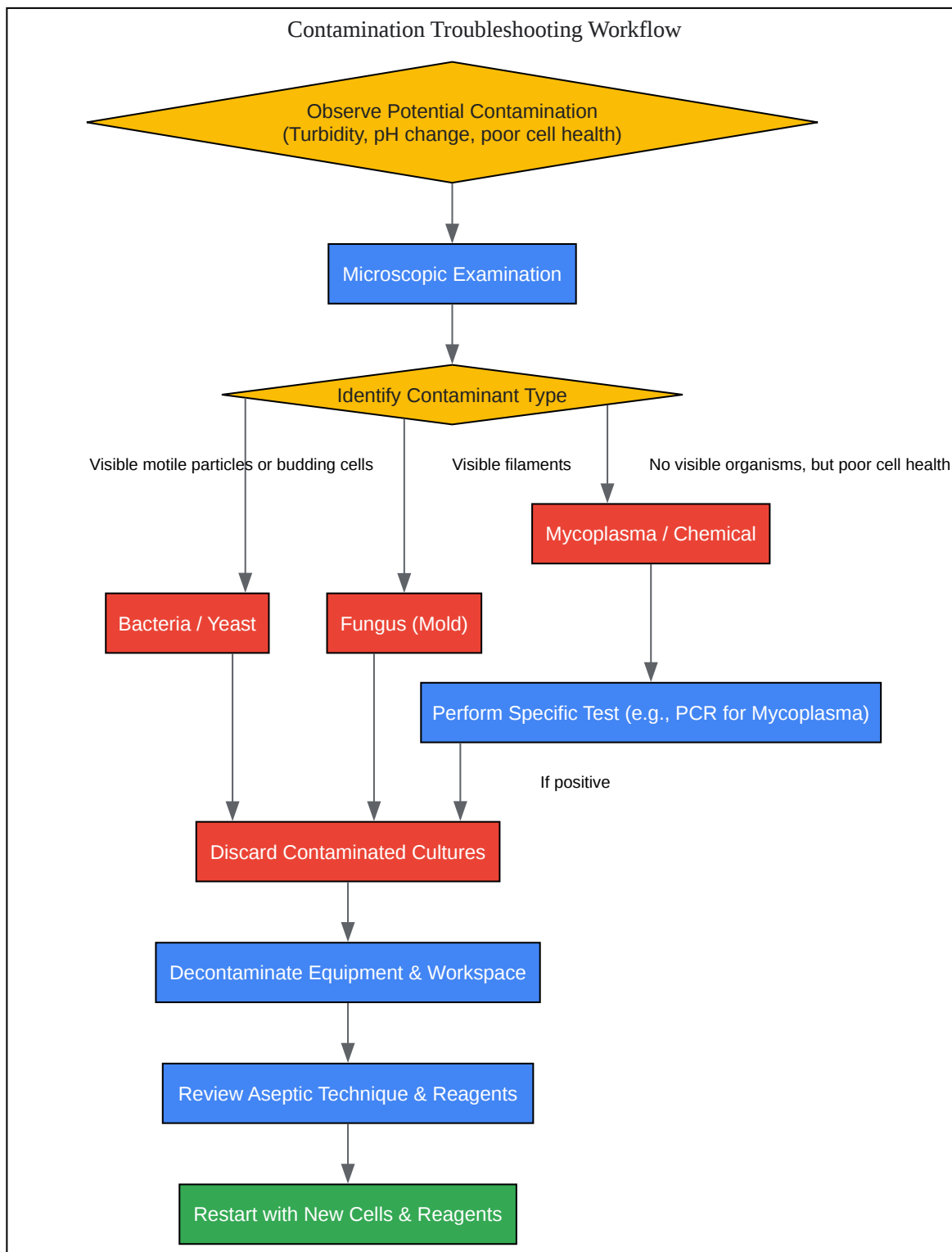

[Click to download full resolution via product page](#)

Caption: A logical workflow for troubleshooting cell culture contamination.

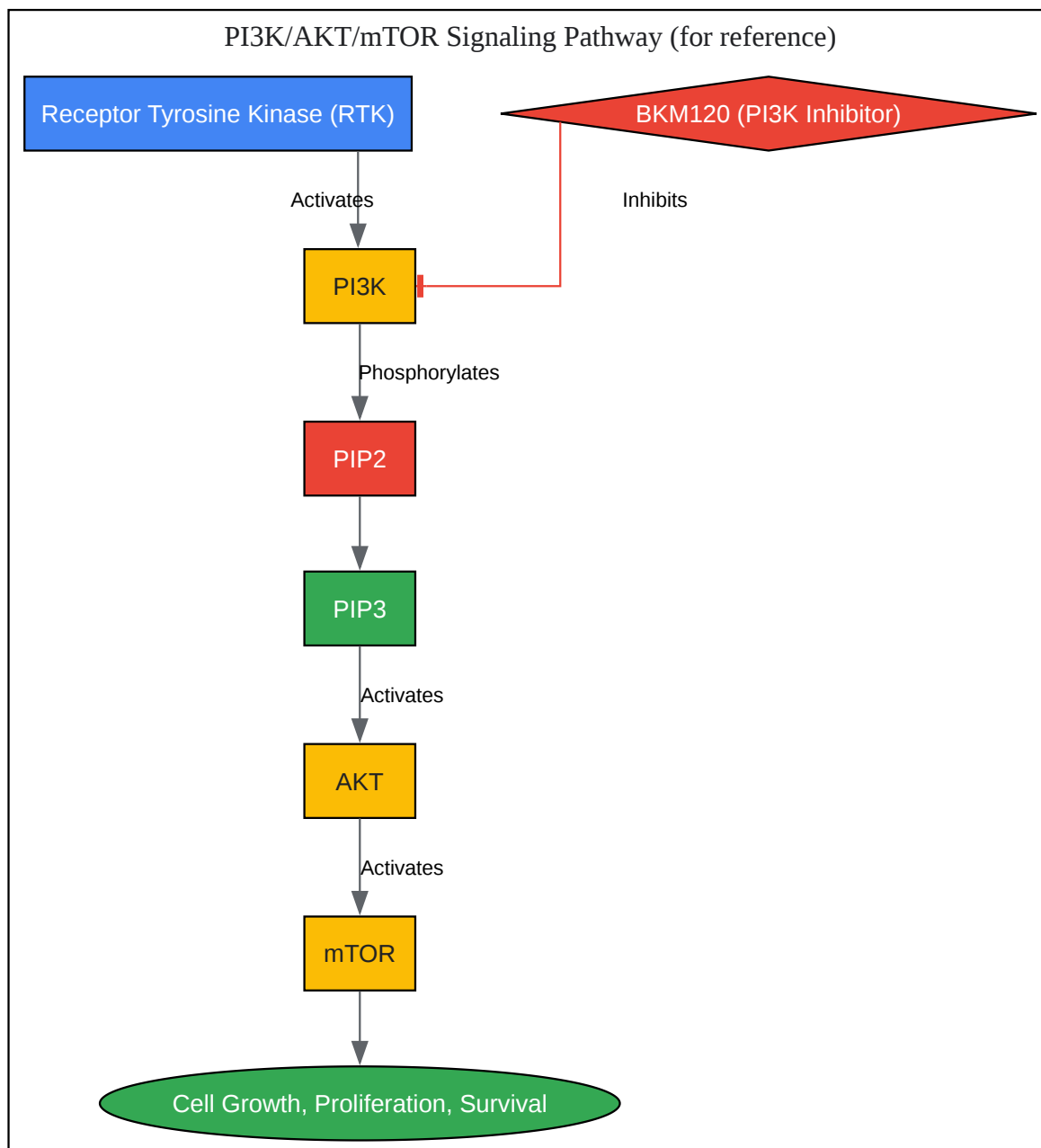

[Click to download full resolution via product page](#)

Caption: The PI3K/AKT/mTOR pathway, inhibited by drugs like BKM120.

Need Custom Synthesis?

BenchChem offers custom synthesis for rare earth carbides and specific isotopic labeling.

Email: info@benchchem.com or [Request Quote Online](#).

References

- 1. Strong cytotoxic effect of the bradykinin antagonist BKM-570 in ovarian cancer cells-- analysis of the molecular mechanisms of its antiproliferative action - PubMed [pubmed.ncbi.nlm.nih.gov]
- 2. Cell Culture Contamination | Thermo Fisher Scientific - HK [thermofisher.com]
- 3. Cell Culture Contamination: 5 Common Sources and How to Prevent Them [capricorn-scientific.com]
- 4. Types of Cell Culture Contamination and How To Prevent Them | Technology Networks [technologynetworks.com]
- 5. goldbio.com [goldbio.com]
- 6. yeasenbio.com [yeasenbio.com]
- 7. creative-bioarray.com [creative-bioarray.com]
- 8. mscience.com.au [mscience.com.au]
- 9. cellculturecompany.com [cellculturecompany.com]
- 10. cellculturecompany.com [cellculturecompany.com]
- 11. corning.com [corning.com]
- 12. safety.fsu.edu [safety.fsu.edu]
- 13. drugdiscoverytrends.com [drugdiscoverytrends.com]
- 14. ibidi.com [ibidi.com]
- 15. researchgate.net [researchgate.net]
- To cite this document: BenchChem. [Technical Support Center: BKM-570 Studies & Cell Culture Contamination]. BenchChem, [2026]. [Online PDF]. Available at: [<https://www.benchchem.com/product/b15291636/docs#technical-support-center-bkm-570-studies-cell-culture-contamination>]

Disclaimer & Data Validity:

The information provided in this document is for Research Use Only (RUO) and is strictly not intended for diagnostic or therapeutic procedures. While BenchChem strives to provide accurate protocols, we make no warranties, express or implied, regarding the fitness of this product for every specific experimental setup.

Technical Support: The protocols provided are for reference purposes. Unsure if this reagent suits your experiment?

Need Industrial/Bulk Grade? [Request Custom Synthesis Quote](#)

BenchChem

Our mission is to be the trusted global source of essential and advanced chemicals, empowering scientists and researchers to drive progress in science and industry.

Contact

Address: 3281 E Guasti Rd
Ontario, CA 91761, United States
Phone: (601) 213-4426
Email: info@benchchem.com

[Contact our Ph.D. Support Team for a compatibility check](#)