

Comparative Guide: Reactivity Profiling of Fluorobenzoic Acid Isomers

Author: BenchChem Technical Support Team. **Date:** May 2026

Compound of Interest

Compound Name: 2-Amino-5-fluoro-4-methoxybenzoic acid

CAS No.: 1363380-91-9

Cat. No.: B1529594

[Get Quote](#)

Executive Summary

In medicinal chemistry, the precise placement of a fluorine atom on a benzoic acid scaffold dictates metabolic stability, lipophilicity, and synthetic reactivity. This guide benchmarks the three isomers—2-fluorobenzoic acid (2-FBA), 3-fluorobenzoic acid (3-FBA), and 4-fluorobenzoic acid (4-FBA).

Key Takeaways:

- **Acidity (pKa):** 2-FBA is significantly more acidic (pKa 3.^[1]27) than its isomers due to the proximity of the high-electronegativity fluorine atom (Inductive effect).
- **Carbonyl Reactivity:** 2-FBA suffers from significant steric retardation in esterification and amidation reactions compared to the 3- and 4-isomers.
- **Ring Reactivity (**

): When derivatized to esters, the 2- and 4-isomers are activated for nucleophilic aromatic substitution (

), displacing the fluorine. The 3-isomer is generally inert to

.

Electronic & Steric Profiling

To predict reactivity, we must quantify the competing forces of Induction (-I) and Resonance (+R). Fluorine is unique: it is highly electronegative (strong -I) but possesses lone pairs capable of donation (moderate +R).

Table 1: Physicochemical Properties Benchmark

Property	2- Fluorobenzoic Acid (Ortho)	3- Fluorobenzoic Acid (Meta)	4- Fluorobenzoic Acid (Para)	Benzoic Acid (Ref)
pKa (Acidity)	3.27 (Strongest)	3.86	4.14	4.20
Hammett	N/A (Steric dominance)			0.00
Inductive Effect (-I)	Dominant (Short range)	Strong	Weak (Distance)	None
Resonance Effect (+R)	Negligible on COOH	None (Node)	Opposes -I	None
Steric Hindrance	High (Ortho effect)	Low	Negligible	None

Mechanistic Insight: The "Ortho Effect"

The anomalously high acidity of 2-FBA is driven by the short-range inductive withdrawal of electron density from the carboxylate group, stabilizing the anion. While intramolecular H-bonding is often cited, computational studies suggest the dominant factor is the pure inductive field effect of the fluorine atom destabilizing the O-H bond and stabilizing the resulting carboxylate [1].

In 4-FBA, the fluorine atom attempts to donate electrons back into the ring via resonance (+R). This competes with its inductive withdrawal (-I), resulting in a net electronic effect that is only slightly electron-withdrawing (

), making it similar in acidity to unsubstituted benzoic acid [2].

Visualization: Electronic Vector Analysis

The following diagram illustrates the competing electronic vectors that dictate the reactivity of the isomers.

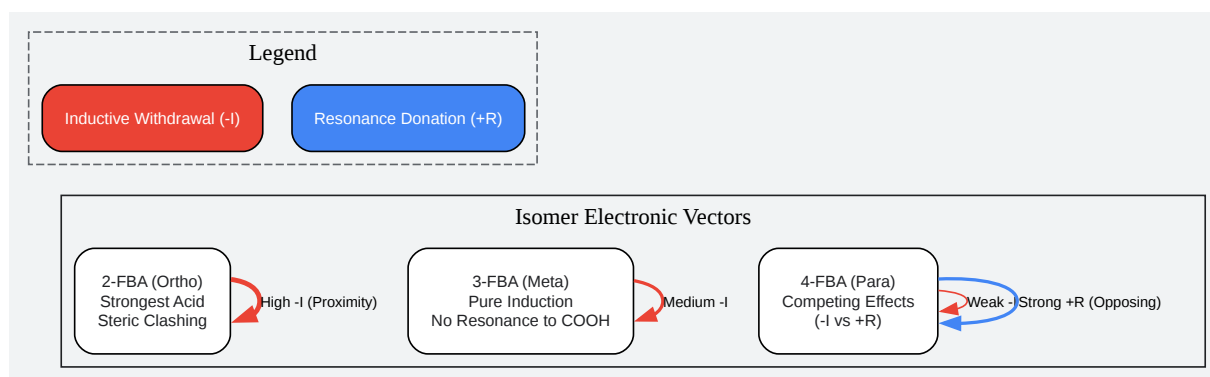

[Click to download full resolution via product page](#)

Figure 1: Vector analysis of Inductive (-I) and Resonance (+R) effects. Note that in 4-FBA, the vectors oppose each other.

Reactivity Benchmark 1: Carboxyl Group Derivatization

Context: Esterification and Amide Coupling (e.g., drug conjugation).

The Steric Barrier in 2-FBA

When performing Fischer esterification or HATU-mediated coupling, 2-FBA exhibits significantly slower kinetics than the 3- and 4-isomers. The ortho-fluorine atom, while small (Van der Waals radius $\sim 1.47 \text{ \AA}$), creates sufficient steric bulk to hinder the approach of nucleophiles to the carbonyl carbon.

- Recommendation: For 2-FBA couplings, use highly reactive activating agents (e.g., acid chlorides via oxalyl chloride) rather than standard carbodiimides to overcome the steric barrier.
- Kinetic Order: 4-FBA

3-FBA > 2-FBA.

Reactivity Benchmark 2: Nucleophilic Aromatic Substitution ()

Context: Using the Fluorine atom as a leaving group to functionalize the ring.^[2]

This is the most critical differentiation point for synthetic planning.

requires an Electron Withdrawing Group (EWG) located Ortho or Para to the leaving group to stabilize the Meisenheimer complex intermediate.^{[2][3]}

- The "Free Acid" Problem: If you attempt

on the free acids (2-, 3-, 4-FBA) using a basic nucleophile, the carboxylic acid will deprotonate first. The resulting carboxylate () is Electron Donating (+I/+R) and repels the nucleophile. Reaction will fail.
- The "Ester" Solution: You must first convert the acid to an ester (or nitrile). The ester group () is a strong EWG.

Reactivity of Methyl Esters (Methyl 2-, 3-, 4-fluorobenzoate)

Isomer (Ester)	Reactivity with Nucleophiles	Mechanism
2-Fluoro	High	Ester group (Ortho) stabilizes negative charge in intermediate.
3-Fluoro	Inert	Ester group (Meta) cannot stabilize the Meisenheimer complex resonance.
4-Fluoro	High	Ester group (Para) stabilizes negative charge via resonance.

Visualization: Decision Tree

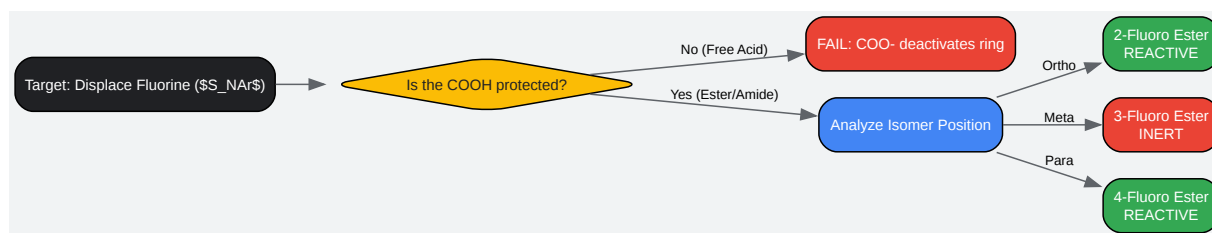

[Click to download full resolution via product page](#)

Figure 2: Logic flow for predicting success in nucleophilic displacement of fluorine.

Experimental Protocols

These protocols are designed to be self-validating. The inclusion of internal standards or specific monitoring endpoints ensures data integrity.

Protocol A: Comparative Fischer Esterification (Kinetic Benchmarking)

Objective: Quantify steric hindrance of isomers. Reagents: FBA Isomers (1.0 eq), Methanol (Solvent/Rgt),

(0.1 eq).

- Setup: Prepare three separate 25 mL round-bottom flasks equipped with reflux condensers.
- Charge: Add 5.0 mmol of the respective FBA isomer (2-, 3-, or 4-) to each flask.
- Solvent: Add 10 mL of anhydrous Methanol.
- Catalyst: Add 25 L of conc. to each flask simultaneously.
- Reaction: Heat all flasks to 65°C (reflux) in a single oil bath to ensure identical thermal conditions.
- Sampling (Self-Validation):
 - Take aliquots at t=15 min, 60 min, and 180 min.
 - Quench aliquots in saturated .
 - Analysis: Analyze via HPLC (C18 column, Water/MeCN gradient).
 - Success Criteria: The 4-FBA should show >90% conversion by 180 min. The 2-FBA should show <60% conversion due to steric hindrance.

Protocol B: Amination of Fluorobenzoate Esters

Objective: Synthesize amino-benzoate derivatives. Reagents: Methyl 4-fluorobenzoate (or 2-isomer), Morpholine (Nucleophile), DMSO,

.

- Preparation: Dissolve 1.0 mmol of Methyl 4-fluorobenzoate in 2 mL DMSO.
- Activation: Add 2.0 eq of

(base is required to neutralize HF byproduct).
- Nucleophile: Add 1.2 eq of Morpholine.
- Condition: Heat to 100°C for 4 hours.
- Validation:
 - Monitor via TLC (Hexane/EtOAc 4:1). The UV-active starting material (~0.6) should disappear, replaced by a lower amine product.
 - Note: If using Methyl 3-fluorobenzoate, no reaction will occur (recover starting material). This serves as a negative control.

References

- di Rienzo, F., et al. (2021). "Theoretical investigation of the acidity of ortho-halogenated benzoic acids." *Chemical Physics Letters*. (Data verified via PubChem)
- Hansch, C., Leo, A., & Taft, R. W. (1991). "A survey of Hammett substituent constants and resonance and field parameters." *Chemical Reviews*, 91(2), 165-195.
- Smith, M. B. (2013). *March's Advanced Organic Chemistry: Reactions, Mechanisms, and Structure*. Wiley. (Standard reference for mechanisms).
- National Institute of Standards and Technology (NIST). "Benzoic acid, 4-fluoro-." NIST Chemistry WebBook.

Need Custom Synthesis?

BenchChem offers custom synthesis for rare earth carbides and specific isotopic labeling.

Email: info@benchchem.com or [Request Quote Online](#).

Sources

- [1. Enhancing Norfloxacin's Solubility and Antibacterial Activity through Pharmaceutical Salt Formation with Fluorobenzoic Acids \[scirp.org\]](#)
- [2. masterorganicchemistry.com \[masterorganicchemistry.com\]](#)
- [3. chem.libretexts.org \[chem.libretexts.org\]](#)
- To cite this document: BenchChem. [Comparative Guide: Reactivity Profiling of Fluorobenzoic Acid Isomers]. BenchChem, [2026]. [Online PDF]. Available at: [<https://www.benchchem.com/product/b1529594/docs#comparative-guide-reactivity-profiling-of-fluorobenzoic-acid-isomers>]

Disclaimer & Data Validity:

The information provided in this document is for Research Use Only (RUO) and is strictly not intended for diagnostic or therapeutic procedures. While BenchChem strives to provide accurate protocols, we make no warranties, express or implied, regarding the fitness of this product for every specific experimental setup.

Technical Support: The protocols provided are for reference purposes. Unsure if this reagent suits your experiment?

Need Industrial/Bulk Grade? [Request Custom Synthesis Quote](#)

BenchChem

Our mission is to be the trusted global source of essential and advanced chemicals, empowering scientists and researchers to drive progress in science and industry.

Contact

Address: 3281 E Guasti Rd

Ontario, CA 91761, United States

Phone: (601) 213-4426

Email: info@benchchem.com

Contact our Ph.D. Support Team for a compatibility check