

# Technical Support Center: Purifying Thalidomide-o-PEG2-acid Based PROTACs

**Author:** BenchChem Technical Support Team. **Date:** April 2026

## Compound of Interest

Compound Name: *Thalidomide-o-PEG2-acid*

Cat. No.: *B15289940*

[Get Quote](#)

Welcome to the Technical Support Center for researchers, scientists, and drug development professionals. This resource provides troubleshooting guides and frequently asked questions (FAQs) to address the unique challenges encountered during the purification of **Thalidomide-o-PEG2-acid** based PROTACs.

## Frequently Asked Questions (FAQs)

Q1: What is the primary method for purifying **Thalidomide-o-PEG2-acid** based PROTACs?

A1: The standard and most effective method for purifying **Thalidomide-o-PEG2-acid** based PROTACs is preparative reverse-phase high-performance liquid chromatography (RP-HPLC). This technique separates the target PROTAC from unreacted starting materials, byproducts, and other impurities based on differences in their hydrophobicity.

Q2: What are the most common impurities observed during the synthesis and purification of these PROTACs?

A2: A significant challenge in the synthesis of thalidomide-based PROTACs is the formation of a cryptic impurity due to a competing nucleophilic acyl substitution reaction. This byproduct can often co-elute with the desired PROTAC molecule during HPLC purification, making its removal

difficult.[1] Other common impurities include unreacted starting materials, such as the warhead, linker, and E3 ligase ligand, as well as products of side reactions.

Q3: How does the **Thalidomide-o-PEG2-acid** linker influence the purification process?

A3: The polyethylene glycol (PEG) linker, while beneficial for solubility and cell permeability, can introduce purification challenges. The hydrophilic nature of the PEG chain can alter the retention behavior of the PROTAC on a reverse-phase column, potentially leading to broader peaks or co-elution with polar impurities.[2][3] Additionally, the flexibility of the PEG linker can sometimes contribute to conformational heterogeneity, which may also result in peak broadening.

Q4: What analytical techniques are recommended for assessing the purity of the final PROTAC product?

A4: A combination of analytical techniques is essential for confirming the purity and identity of the purified **Thalidomide-o-PEG2-acid** based PROTAC. High-resolution mass spectrometry (HRMS) is used to verify the molecular weight of the final product. Nuclear magnetic resonance (NMR) spectroscopy confirms the chemical structure and the absence of impurities. Analytical HPLC with UV detection is crucial for determining the purity of the final compound, with a target purity of >95% being a common standard.[4]

## Troubleshooting Guide

This guide addresses common issues encountered during the preparative HPLC purification of **Thalidomide-o-PEG2-acid** based PROTACs.

Problem	Potential Cause	Recommended Solution
Co-elution of Impurity with Product	A common impurity arises from nucleophilic acyl substitution on the thalidomide moiety, which can have a similar retention time to the desired PROTAC.[1]	<ul style="list-style-type: none"> <li>- Reaction Optimization: Consider using a scavenger agent like taurine during the synthesis to minimize the formation of this byproduct.[1]-</li> <li>- Chromatographic Selectivity: Experiment with different stationary phases (e.g., C8 instead of C18) or mobile phase modifiers to alter the selectivity of the separation.-</li> <li>- Gradient Optimization: Employ a shallower gradient around the elution time of the product to improve resolution.</li> </ul>
Peak Tailing	<ul style="list-style-type: none"> <li>- Secondary Interactions: The thalidomide moiety or other functional groups on the PROTAC can have secondary interactions with residual silanol groups on the silica-based stationary phase.-</li> <li>- Column Overload: Injecting too much sample can lead to peak distortion.</li> </ul>	<ul style="list-style-type: none"> <li>- Mobile Phase Additives: Add a small amount of a competitive agent, such as trifluoroacetic acid (TFA) or formic acid (0.1%), to the mobile phase to mask silanol interactions.-</li> <li>- Reduce Sample Load: Decrease the amount of crude product injected onto the column.-</li> <li>- Alternative Stationary Phase: Consider using a column with end-capping to reduce silanol activity.</li> </ul>
Peak Broadening	<ul style="list-style-type: none"> <li>- Slow Kinetics: The flexible PEG linker may lead to slow on-off rates on the stationary phase.-</li> <li>- Conformational Isomers: The PROTAC may exist in multiple conformations</li> </ul>	<ul style="list-style-type: none"> <li>- Temperature: Increase the column temperature (e.g., to 40°C) to improve mass transfer kinetics and reduce peak width.-</li> <li>- Flow Rate: Optimize the flow rate to find the best balance between</li> </ul>

that interconvert slowly on the chromatographic timescale.

resolution and analysis time.-

Mobile Phase Composition:  
Adjust the organic solvent percentage to sharpen the peaks.

Low Recovery/Yield

- Poor Solubility: The PROTAC may not be fully dissolved in the injection solvent, leading to precipitation on the column.- Adsorption: The compound may be irreversibly adsorbed to the column or system components.

- Solvent Optimization: Ensure the crude product is fully dissolved in a suitable solvent, such as DMSO or a mixture of the mobile phase components, before injection.- System Passivation: Flush the HPLC system with a strong solvent to remove any adsorbed material from previous runs.- Column Choice: In rare cases of extreme adsorption, a different type of stationary phase may be necessary.

PROTAC Aggregation

The amphiphilic nature of some PROTACs, with a hydrophobic warhead and a hydrophilic PEG linker, can lead to aggregation, especially at high concentrations.

- Sample Preparation: Prepare the sample for injection at a lower concentration if possible.- Mobile Phase Modifiers: The addition of organic modifiers like isopropanol to the mobile phase can sometimes disrupt aggregates.- Excipients: In challenging cases, the addition of small amounts of non-ionic detergents or other excipients to the sample might be considered, though this can complicate the purification process.

## Experimental Protocols

### Preparative RP-HPLC Purification of Thalidomide-o-PEG2-acid based PROTACs

This protocol provides a general guideline. Optimization of the gradient and other parameters will be necessary for each specific PROTAC.

#### 1. Sample Preparation:

- Dissolve the crude PROTAC material in a minimal amount of a suitable solvent (e.g., DMSO, DMF, or a 1:1 mixture of acetonitrile and water).
- Ensure the sample is fully dissolved. Sonication may be used to aid dissolution.
- Filter the sample through a 0.45  $\mu\text{m}$  syringe filter to remove any particulate matter before injection.

#### 2. HPLC Conditions:

Parameter	Typical Setting
Column	C18 reverse-phase column (e.g., 19 x 150 mm, 5 $\mu\text{m}$ particle size)
Mobile Phase A	Water with 0.1% Trifluoroacetic Acid (TFA) or 0.1% Formic Acid
Mobile Phase B	Acetonitrile with 0.1% Trifluoroacetic Acid (TFA) or 0.1% Formic Acid
Gradient	10-90% B over 30 minutes (this should be optimized)
Flow Rate	15-20 mL/min
Detection	UV at 254 nm or another appropriate wavelength
Column Temperature	Ambient or 40°C

### 3. Purification Procedure:

- Equilibrate the column with the initial mobile phase composition (e.g., 10% B) for at least 5-10 column volumes.
- Inject the filtered sample onto the column.
- Run the gradient elution as optimized.
- Collect fractions based on the UV chromatogram, isolating the peak corresponding to the desired PROTAC.

### 4. Post-Purification:

- Analyze the collected fractions using analytical LC-MS to confirm the presence and purity of the target compound.
- Pool the pure fractions.
- Remove the organic solvent (acetonitrile) using a rotary evaporator.
- Lyophilize the remaining aqueous solution to obtain the purified PROTAC as a solid.

## Visualizations

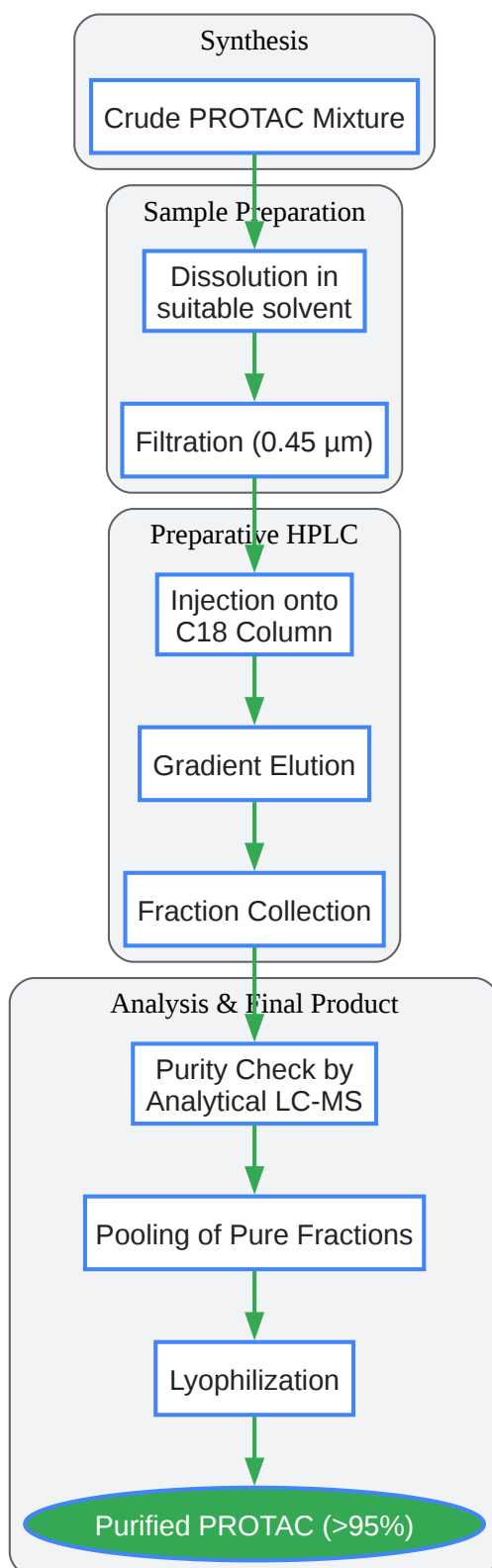

[Click to download full resolution via product page](#)

Caption: Workflow for the purification of **Thalidomide-o-PEG2-acid** based PROTACs.

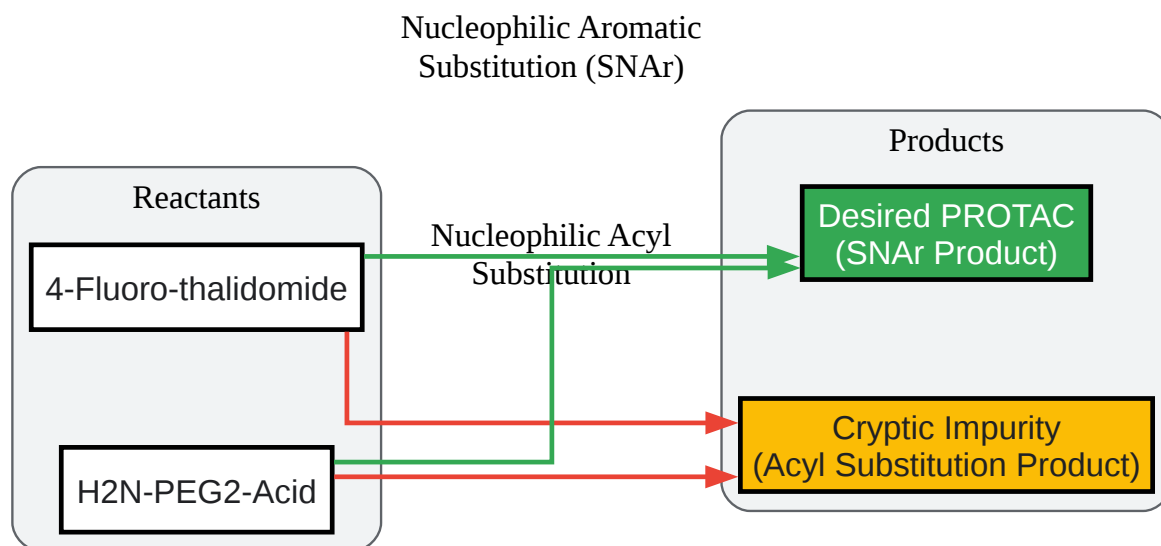

[Click to download full resolution via product page](#)

Caption: Competing reaction pathways in the synthesis of Thalidomide-based PROTACs.

### Need Custom Synthesis?

BenchChem offers custom synthesis for rare earth carbides and specific isotopic labeling.

Email: [info@benchchem.com](mailto:info@benchchem.com) or [Request Quote Online](#).

## References

- 1. [researchgate.net](https://www.researchgate.net) [researchgate.net]
- 2. Characterization of the Reversed-Phase Chromatographic Behavior of PEGylated Peptides Based on the Poly(ethylene glycol) Dispersity - PubMed [pubmed.ncbi.nlm.nih.gov]
- 3. [researchgate.net](https://www.researchgate.net) [researchgate.net]
- 4. [benchchem.com](https://www.benchchem.com) [benchchem.com]
- To cite this document: BenchChem. [Technical Support Center: Purifying Thalidomide-o-PEG<sub>2</sub>-acid Based PROTACs]. BenchChem, [2026]. [Online PDF]. Available at: [https://www.benchchem.com/product/b15289940/docs#technical-support-center-purifying-thalidomide-o-peg2-acid-based-protacs]

**Disclaimer & Data Validity:**

The information provided in this document is for Research Use Only (RUO) and is strictly not intended for diagnostic or therapeutic procedures. While BenchChem strives to provide accurate protocols, we make no warranties, express or implied, regarding the fitness of this product for every specific experimental setup.

**Technical Support:** The protocols provided are for reference purposes. Unsure if this reagent suits your experiment?

**Need Industrial/Bulk Grade?** [Request Custom Synthesis Quote](#)

## BenchChem

Our mission is to be the trusted global source of essential and advanced chemicals, empowering scientists and researchers to drive progress in science and industry.

### Contact

Address: 3281 E Guasti Rd  
Ontario, CA 91761, United States  
Phone: (601) 213-4426  
Email: [info@benchchem.com](mailto:info@benchchem.com)

[Contact our Ph.D. Support Team for a compatibility check](#)