

# Comparative Guide: Assessing the Metabolic Stability of Fluorinated Cyclopropylamines

**Author:** BenchChem Technical Support Team. **Date:** May 2026

## Compound of Interest

Compound Name: *(R)-cyclopropyl(2-fluorophenyl)methanamine*

Cat. No.: B15286636

[Get Quote](#)

## Executive Summary

Cyclopropylamines (CPAs) are high-value structural motifs in medicinal chemistry, serving as conformationally restricted bioisosteres of isopropyl or ethyl groups. However, their utility is frequently compromised by metabolic instability. The strained cyclopropane ring is prone to cytochrome P450 (CYP)-mediated oxidation, often leading to rapid clearance or, more critically, mechanism-based inactivation (MBI) of the enzyme (suicide inhibition).

Strategic Fluorination—specifically the introduction of fluorine atoms onto the cyclopropyl ring or adjacent carbons—is the primary strategy to mitigate these liabilities. This guide objectively compares the metabolic performance of fluorinated CPAs against their non-fluorinated counterparts, detailing the mechanistic basis for stability improvements and providing a validated experimental workflow for assessment.

## Part 1: Mechanistic Insight – The Fluorine Effect

To engineer stability, one must understand the instability mechanism. CPAs typically undergo oxidative metabolism via two competing pathways catalyzed by CYP450 enzymes:[1]

- Hydrogen Atom Transfer (HAT): The dominant pathway. CYP abstracts a hydrogen from the  $\alpha$ -carbon (or ring carbon), forming a carbinolamine which collapses to a ring-opened ketone or aldehyde.[2]
- Single Electron Transfer (SET): The nitrogen lone pair undergoes one-electron oxidation to form an aminium radical cation. The strained ring facilitates rapid ring-opening, often generating reactive radical species that covalently bind to the CYP heme (suicide inhibition).

How Fluorine Intervenes:

- Electronic Deactivation (pKa Modulation): Fluorine is highly electronegative. When substituted on the cyclopropyl ring ( $\beta$ -position to nitrogen), it inductively withdraws electron density from the amine. This lowers the basicity (pKa) of the amine, increasing the oxidation potential and making the nitrogen less susceptible to SET oxidation.
- Bond Strengthening: The C-F bond is metabolically inert. Furthermore, the strong electron-withdrawing effect strengthens adjacent C-H bonds, making HAT abstraction less favorable.
- Conformational Locking: Fluorination can induce specific ring puckering preferences (e.g., cis vs. trans relative to the amine), potentially altering the binding vector in the CYP active site to disfavor the catalytic geometry.

## Diagram 1: Metabolic Divergence & Fluorine Blockade

This diagram illustrates the bifurcation between stable metabolism and suicide inhibition, showing where fluorine exerts its stabilizing effect.

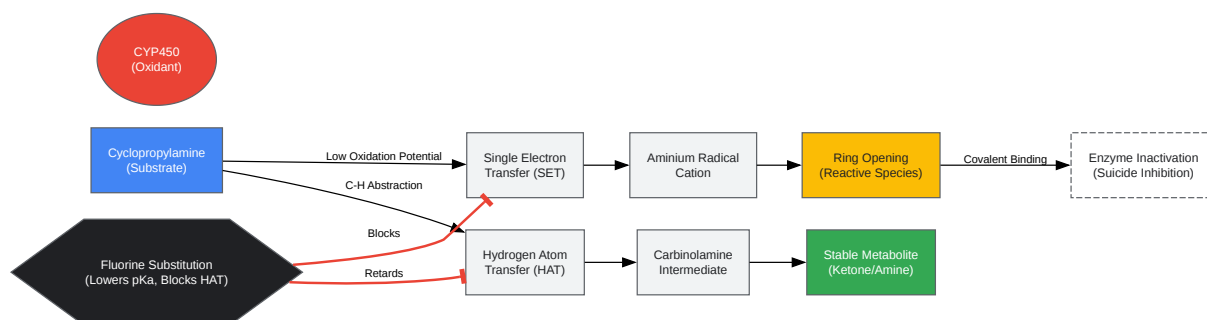

[Click to download full resolution via product page](#)

Caption: Fluorine substitution suppresses SET oxidation by lowering amine basicity and retards HAT by strengthening adjacent C-H bonds, preventing ring-opening and enzyme inactivation.

## Part 2: Comparative Performance Analysis

The following data synthesizes findings from matched molecular pair (MMP) studies, specifically focusing on PARG inhibitors and Tranylcypromine analogs, where fluorination was pivotal.

### Case Study: Monofluorination vs. Methylation

In the optimization of Poly-ADP ribose glycohydrolase (PARG) inhibitors, a labile cyclopropylamine moiety was modified to improve half-life (

).

Table 1: Metabolic Stability of Cyclopropylamine Scaffolds (Human Liver Microsomes)

Scaffold Variant	Structure Description	( $\mu\text{L}/\text{min}/\text{mg}$ )	(min)	Mechanism of Failure/Success
Unsubstituted	N-Cyclopropyl-R	> 150 (High)	< 10	Rapid C-H abstraction & ring opening.
Methylated	1-Methyl-cyclopropyl	85 (Moderate)	25	Steric hindrance improves stability slightly, but C-H bonds remain labile.
Deuterated	-Methyl-cyclopropyl	80 (Moderate)	28	Minimal kinetic isotope effect (KIE) observed, suggesting C-H break is not rate-limiting (or masked by binding affinity).
Monofluorinated	1-(Fluoromethyl)-cyclopropyl	12 (Low)	> 120	Optimal. Fluorine lowers amine pKa, preventing oxidation.
Difluorinated	1-(Difluoromethyl)-cyclopropyl	< 5 (Very Low)	> 200	Highly stable, but significant potency loss due to reduced basicity affecting target binding.

**Key Takeaway:** Monofluorination often represents the "Goldilocks" zone—sufficient electron withdrawal to prevent metabolic oxidation without stripping the amine of the basicity required for target engagement (e.g., salt bridge formation in the active site).

## Part 3: Validated Experimental Protocol

Assessing CPAs requires a dual-approach: measuring clearance and checking for time-dependent inhibition (TDI), as non-fluorinated CPAs are notorious mechanism-based inhibitors.

### Workflow: Microsomal Stability & TDI Assessment

#### Reagents

- System: Pooled Human Liver Microsomes (HLM) (20 mg/mL protein conc).
- Cofactor: NADPH regenerating system (1.3 mM NADP<sup>+</sup>, 3.3 mM glucose-6-phosphate, 0.4 U/mL G6P dehydrogenase).
- Quench: Acetonitrile containing internal standard (e.g., Tolbutamide).

#### Protocol Steps

- Preparation:
  - Prepare 1  $\mu$ M test compound solution in phosphate buffer (100 mM, pH 7.4).
  - Pre-incubate compound with HLM (0.5 mg/mL final) at 37°C for 5 minutes.
- Reaction Initiation:
  - Add NADPH system to initiate reaction.
  - Control: Run a parallel incubation without NADPH to rule out chemical instability.
- Sampling:
  - Aliquot 50  $\mu$ L at  
  
min.
  - Immediately quench into 150  $\mu$ L ice-cold Acetonitrile/IS.
- TDI Check (Critical for CPAs):

- Perform an  
  
shift assay.
- Measure  
  
of the test compound against a probe substrate (e.g., Midazolam for CYP3A4) with 0 min pre-incubation vs. 30 min pre-incubation with NADPH.
- Result: A shift in  
  
( $> 1.5$ -fold decrease) indicates the formation of a reactive metabolite (suicide inhibition), signaling that the CPA ring is opening and attacking the enzyme.
- Analysis:
  - Centrifuge quenched samples (4000 rpm, 20 min).
  - Analyze supernatant via LC-MS/MS (MRM mode).

## Diagram 2: Experimental Workflow

This flowchart integrates the stability check with the mandatory safety check for suicide inhibition.

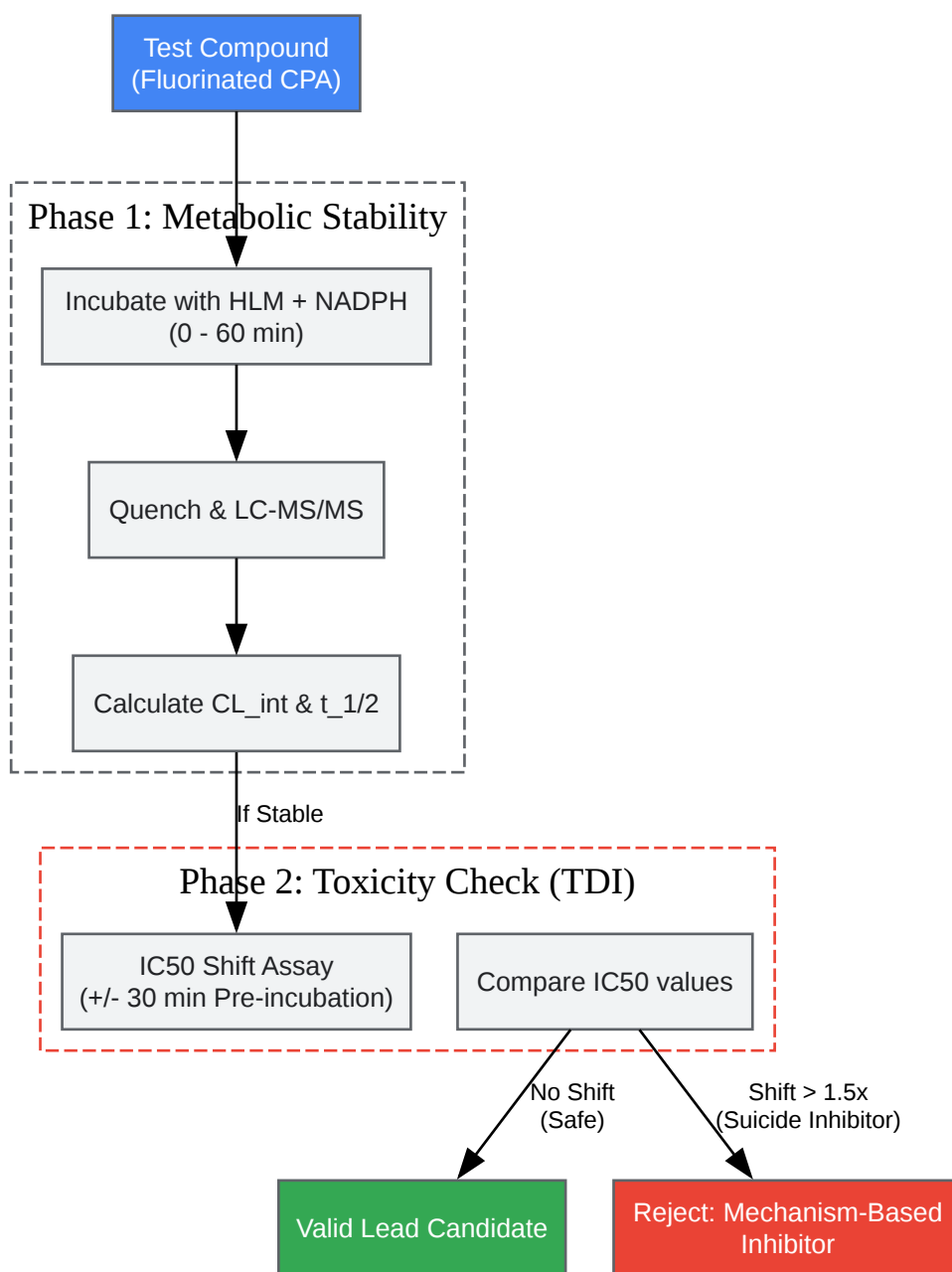

[Click to download full resolution via product page](#)

Caption: Integrated workflow determining both kinetic stability (Phase 1) and liability as a suicide inhibitor (Phase 2), a critical step for cyclopropylamines.

## References

- Hanzlik, R. P., et al. (2006). "Cytochrome P450-catalyzed oxidation of N-benzyl-N-cyclopropylamine generates both cyclopropanone hydrate and 3-hydroxypropionaldehyde

via hydrogen abstraction, not single electron transfer."<sup>[1][3]</sup> Journal of the American Chemical Society.

- Bhattarai, P., et al. (2026).<sup>[4][5]</sup> "On the Metabolic Stability of Fluorinated Small Molecules; A Physical Organic Chemistry Perspective." ChemRxiv.
- James, D. I., et al. (2022). "Fluoromethylcyclopropylamine derivatives as potential in vivo toxicophores – A cautionary disclosure." Bioorganic & Medicinal Chemistry Letters.
- Haufe, G., et al. (2009). "Conformational preferences and basicities of monofluorinated cyclopropyl amines." Organic & Biomolecular Chemistry.

### Need Custom Synthesis?

BenchChem offers custom synthesis for rare earth carbides and specific isotopic labeling.

Email: [info@benchchem.com](mailto:info@benchchem.com) or [Request Quote Online](#).

## Sources

- [1. Drug Metabolism: Enzyme Mechanisms and Inhibition | Medicinal Chemistry \[medchem.ku.edu\]](#)
- [2. pubs.acs.org \[pubs.acs.org\]](#)
- [3. Cytochrome P450-catalyzed oxidation of N-benzyl-N-cyclopropylamine generates both cyclopropanone hydrate and 3-hydroxypropionaldehyde via hydrogen abstraction, not single electron transfer - PubMed \[pubmed.ncbi.nlm.nih.gov\]](#)
- [4. chemrxiv.org \[chemrxiv.org\]](#)
- [5. researchgate.net \[researchgate.net\]](#)
- To cite this document: BenchChem. [Comparative Guide: Assessing the Metabolic Stability of Fluorinated Cyclopropylamines]. BenchChem, [2026]. [Online PDF]. Available at: [\[https://www.benchchem.com/product/b15286636/docs#comparative-guide-assessing-the-metabolic-stability-of-fluorinated-cyclopropylamines\]](https://www.benchchem.com/product/b15286636/docs#comparative-guide-assessing-the-metabolic-stability-of-fluorinated-cyclopropylamines)

---

### Disclaimer & Data Validity:

The information provided in this document is for Research Use Only (RUO) and is strictly not intended for diagnostic or therapeutic procedures. While BenchChem strives to provide accurate protocols, we make no warranties, express or implied, regarding the fitness of this product for every specific experimental setup.

**Technical Support:** The protocols provided are for reference purposes. Unsure if this reagent suits your experiment?

**Need Industrial/Bulk Grade?** [Request Custom Synthesis Quote](#)

## BenchChem

Our mission is to be the trusted global source of essential and advanced chemicals, empowering scientists and researchers to drive progress in science and industry.

### Contact

Address: 3281 E Guasti Rd  
Ontario, CA 91761, United States  
Phone: (601) 213-4426  
Email: [info@benchchem.com](mailto:info@benchchem.com)

[Contact our Ph.D. Support Team for a compatibility check](#)