

Application Note: Regioselective Etherification of 3-Bromo-2-Hydroxypyridine

Author: BenchChem Technical Support Team. **Date:** April 2026

Compound of Interest

Compound Name: 3-Bromo-2-(piperidin-4-ylmethoxy)pyridine

Cat. No.: B15281132

[Get Quote](#)

- vs.

-Alkylation in 3-Halo-2-Hydroxypyridines

Executive Summary & Chemoselectivity Challenge

The etherification of 3-bromo-2-hydroxypyridine (CAS: 13466-43-8) presents a classic yet non-trivial challenge in heterocyclic chemistry: ambident nucleophilicity.

In solution, 3-bromo-2-hydroxypyridine exists in a tautomeric equilibrium between the lactim (2-hydroxypyridine) and lactam (2-pyridone) forms. While the lactam form is thermodynamically favored in polar solvents and the solid state, successful etherification requires trapping the oxygen nucleophile.

- The Trap: Standard alkylation conditions (e.g.,

, alkyl halides, polar aprotic solvents) predominantly yield the

-alkylated product (a pyridone) due to the higher nucleophilicity of the nitrogen atom and the thermodynamic stability of the amide-like carbonyl.

- The 3-Bromo Effect: The bromine atom at the C3 position exerts a strong inductive effect (), increasing the acidity of the N-H proton compared to the unsubstituted parent. Sterically, the bulky bromine atom is ortho to the oxygen, potentially hindering
-attack and further biasing the reaction toward
-alkylation unless specific protocols are employed.

This guide details three distinct protocols to force

-regioselectivity, ranging from silver-mediated sequestration to indirect displacement.

Decision Matrix: Selecting the Right Protocol

Use the following logic flow to determine the optimal synthetic route for your specific application.

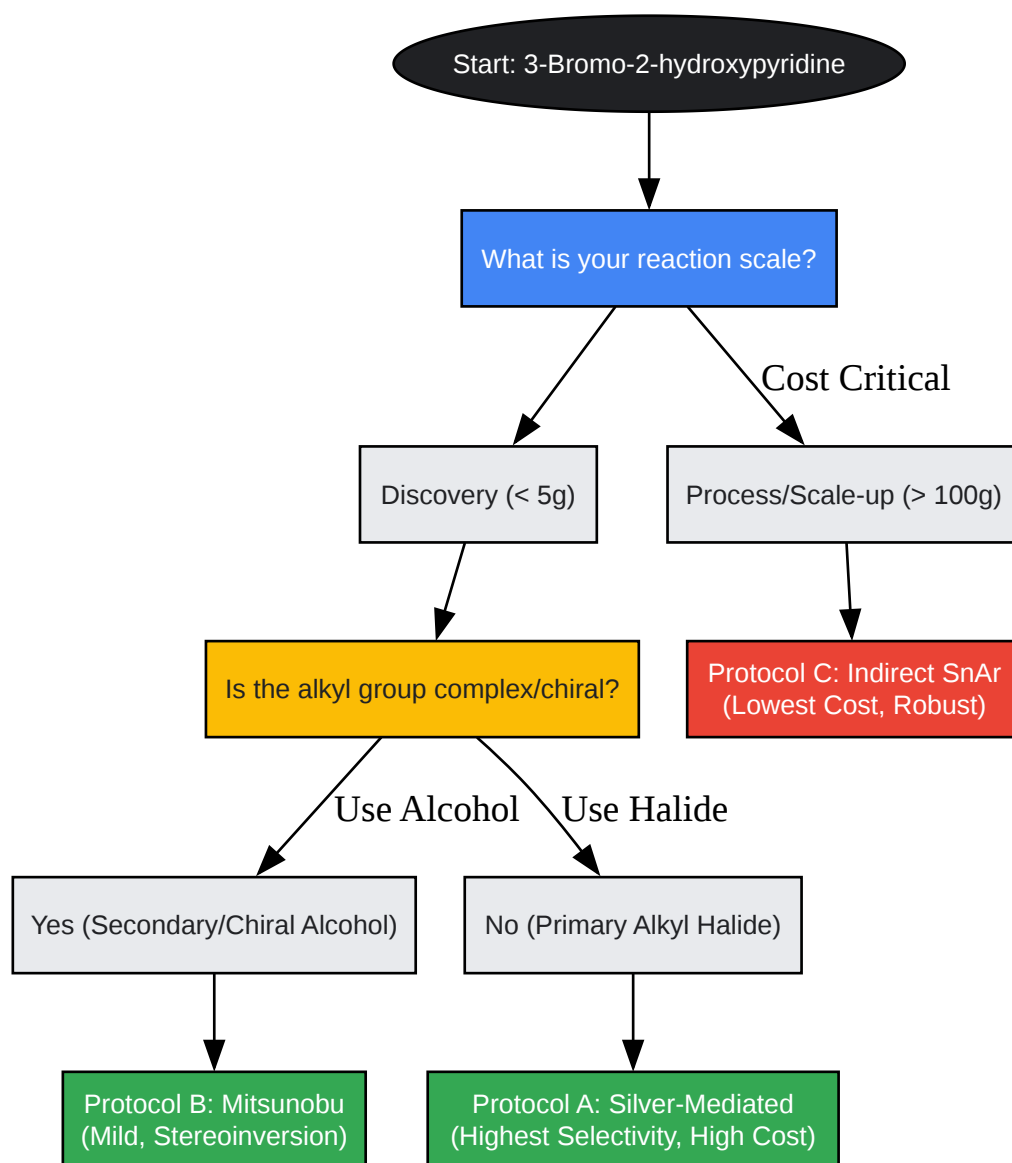

[Click to download full resolution via product page](#)

Figure 1: Strategic decision tree for selecting the etherification method based on scale and substrate complexity.

Protocol A: Silver-Mediated Direct -Alkylation

Best For: Small-scale synthesis, primary alkyl halides, high-value intermediates.

Mechanistic Insight

This method utilizes the Hard and Soft Acids and Bases (HSAB) principle. The silver cation (

) acts as a soft Lewis acid and coordinates preferentially to the nitrogen lone pair (soft base) and the bromine atom. This coordination effectively "blocks" the nitrogen site and forces the alkylating agent to attack the "harder" oxygen center.

Materials

- Substrate: 3-Bromo-2-hydroxypyridine (1.0 equiv)
- Reagent: Silver Carbonate () (0.6 – 1.0 equiv)
- Electrophile: Alkyl Iodide or Bromide (1.2 equiv)
- Solvent: Toluene (preferred) or Benzene (traditional); non-polar solvents suppress the charge-separated transition state required for -alkylation.

Step-by-Step Procedure

- Setup: Flame-dry a round-bottom flask equipped with a magnetic stir bar and a reflux condenser. Flush with Nitrogen or Argon.
- Solvation: Suspend 3-bromo-2-hydroxypyridine (1.0 g, 5.75 mmol) and (1.58 g, 5.75 mmol) in anhydrous Toluene (20 mL).
 - Note: The mixture must be protected from light (wrap flask in foil) to prevent silver salt degradation.
- Addition: Add the alkyl iodide (6.9 mmol) via syringe.
- Reaction: Heat the mixture to reflux (C) for 12–18 hours.
 - Monitoring: Check TLC (Hexane/EtOAc).[1] The -alkyl product typically has a higher

(less polar) than the

-alkyl byproduct.

- Workup: Cool to room temperature. Filter the mixture through a pad of Celite to remove silver salts. Wash the pad with DCM.
- Purification: Concentrate the filtrate. Purify via flash column chromatography (Silica gel, 0-20% EtOAc in Hexanes).

Expected Outcome: >90%

-selectivity.

Protocol B: The Mitsunobu Reaction

Best For: Secondary alcohols, chiral substrates, and when alkyl halides are unstable.

Mechanistic Insight

The Mitsunobu reaction activates an alcohol using a phosphine and an azodicarboxylate to form an oxy-phosphonium intermediate. The 2-hydroxypyridine acts as the acidic pronucleophile (

). Because the oxy-phosphonium bond is formed with the alcohol oxygen, the nucleophilic attack must come from the pyridone oxygen or nitrogen. In non-polar solvents like THF or Toluene, the

-attack is kinetically favored.

Materials

- Substrate: 3-Bromo-2-hydroxypyridine (1.0 equiv)
- Alcohol: R-OH (1.0 – 1.2 equiv)
- Phosphine: Triphenylphosphine () (1.5 equiv)
- Azodicarboxylate: DIAD (Diisopropyl azodicarboxylate) or DEAD (1.5 equiv)[2]

- Solvent: Anhydrous THF.

Step-by-Step Procedure

- Setup: Dry a reaction vessel and maintain an inert atmosphere ().
- Dissolution: Dissolve 3-bromo-2-hydroxypyridine (1.0 equiv), the Alcohol (1.0 equiv), and (1.5 equiv) in anhydrous THF (0.1 M concentration).
- Cooling: Cool the solution to C using an ice bath.
- Addition: Add DIAD (1.5 equiv) dropwise over 15–20 minutes.
 - Critical: The reaction is exothermic. Maintain temperature C during addition to prevent side reactions.
- Reaction: Remove the ice bath and allow to stir at Room Temperature (RT) for 12–24 hours.
- Workup: Concentrate the solvent. Triturate the residue with Hexane/Ether (1:1) to precipitate Triphenylphosphine oxide (TPPO).[2] Filter off the solid.
- Purification: Chromatography is required to separate the product from residual hydrazine byproducts.

Expected Outcome: 70–85% Yield, exclusive

-alkylation.

Protocol C: Indirect Route via (Scale-Up)

Best For: Multi-gram to Kilo-scale synthesis, simple alkyl groups (Methyl, Ethyl).

Mechanistic Insight

Instead of fighting the tautomeric equilibrium, this route converts the C2-hydroxyl into a C2-chloride (a leaving group). The 3-bromo substituent activates the C2 position for Nucleophilic Aromatic Substitution (

) by an alkoxide. This guarantees the formation of the ether bond, as no nitrogen nucleophile is present in the displacement step.

Materials

- Step 1:

(Phosphorus oxychloride), catalytic DMF.

- Step 2: Sodium Alkoxide (NaOR) in corresponding alcohol (ROH).

Step-by-Step Procedure

Step 1: Chlorination

- Mix 3-bromo-2-hydroxypyridine (10 g) with (30 mL). Add 2-3 drops of DMF.
- Reflux (C) for 3 hours until the solid dissolves and gas evolution ceases.
- Remove excess under reduced pressure (rotary evaporator with caustic trap).
- Pour residue onto ice-water carefully. Neutralize with . Extract with DCM to obtain 3-bromo-2-chloropyridine.

Step 2: Etherification (

)

- Dissolve 3-bromo-2-chloropyridine (1.0 equiv) in the alcohol (e.g., Methanol).

- Add Sodium Methoxide (NaOMe) (1.2 equiv) solid or solution.
- Reflux for 4–6 hours.
 - Note: The 3-bromo group makes the C2-Cl more reactive towards displacement than in un-substituted 2-chloropyridine.
- Concentrate, add water, and extract with EtOAc.

Expected Outcome: Near quantitative conversion, 100% Regiopurity.

Comparative Data & QC

Reaction Pathway Visualization

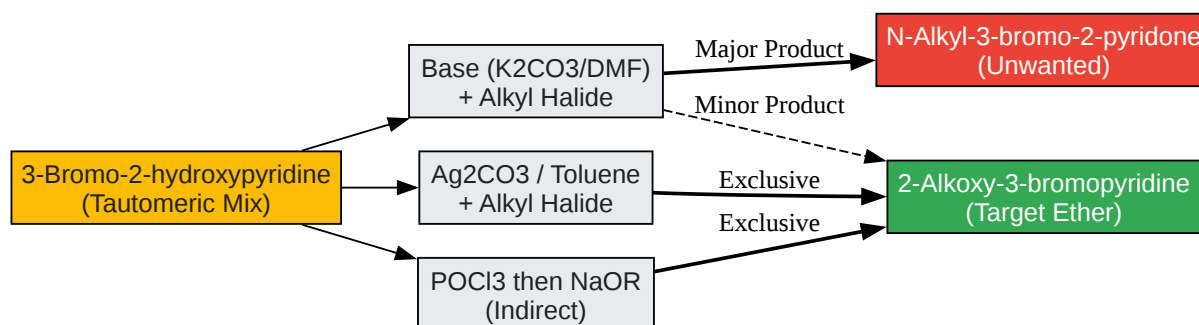

[Click to download full resolution via product page](#)

Figure 2: Reaction pathways showing the divergence in regioselectivity based on conditions.

Quality Control: NMR Identification

Distinguishing the isomers is critical. Use the following diagnostic signals (

NMR in

):

Feature	-Alkyl Product (Ether)	-Alkyl Product (Pyridone)
-Protons (vs)	Typically 4.0 – 4.5 ppm	Typically 3.5 – 4.0 ppm (Shielded)
Ring C-H Coupling	Distinct aromatic splitting	Often broader due to N-quadrupole
Carbonyl/C-O	ppm (C-O)	ppm (C=O)
IR Spectroscopy	No strong Carbonyl stretch	Strong Amide C=O stretch ()

References

- Chung, N. M., et al. "Mild, efficient and selective silver carbonate mediated O-alkylation of 4-hydroxy-2-quinolones." *Tetrahedron Letters*, 2002. (Demonstrates Ag₂CO₃ selectivity rules).
- Katritzky, A. R., et al. "The Tautomerism of Heterocycles." *Advances in Heterocyclic Chemistry*, Vol 76. (Foundational text on Pyridone/Hydroxypyridine equilibrium).
- Mitsunobu, O. "The Use of Diethyl Azodicarboxylate and Triphenylphosphine in Synthesis and Transformation of Natural Products." *Synthesis*, 1981.[3][4] (Core reference for Protocol B).
- Spitzner, R. "Pyridine-N-oxides and Their Derivatives." *Science of Synthesis*, 2005. (Detailed review of Halopyridine reactivity and displacements).
- Patent US20060100244A1. "Synthesis of substituted pyridine ethers." (Industrial conditions for chlorination/displacement of 3-bromo-2-hydroxypyridine).

Need Custom Synthesis?

BenchChem offers custom synthesis for rare earth carbides and specific isotopic labeling.

Email: info@benchchem.com or [Request Quote Online](#).

Sources

- [1. A Mild and Highly Diastereoselective Preparation of N-Alkenyl-2-Pyridones via 2-Halopyridinium Salts and Aldehydes - PMC \[pmc.ncbi.nlm.nih.gov\]](#)
- [2. organic-synthesis.com \[organic-synthesis.com\]](#)
- [3. atlanchimpharma.com \[atlanchimpharma.com\]](#)
- [4. Mechanism of the Mitsunobu Reaction: An Ongoing Mystery - PMC \[pmc.ncbi.nlm.nih.gov\]](#)
- To cite this document: BenchChem. [Application Note: Regioselective Etherification of 3-Bromo-2-Hydroxypyridine]. BenchChem, [2026]. [Online PDF]. Available at: [\[https://www.benchchem.com/product/b15281132/docs#application-note-regioselective-etherification-of-3-bromo-2-hydroxypyridine\]](https://www.benchchem.com/product/b15281132/docs#application-note-regioselective-etherification-of-3-bromo-2-hydroxypyridine)

Disclaimer & Data Validity:

The information provided in this document is for Research Use Only (RUO) and is strictly not intended for diagnostic or therapeutic procedures. While BenchChem strives to provide accurate protocols, we make no warranties, express or implied, regarding the fitness of this product for every specific experimental setup.

Technical Support: The protocols provided are for reference purposes. Unsure if this reagent suits your experiment?

Need Industrial/Bulk Grade? [Request Custom Synthesis Quote](#)

BenchChem

Our mission is to be the trusted global source of essential and advanced chemicals, empowering scientists and researchers to drive progress in science and industry.

Contact

Address: 3281 E Guasti Rd
Ontario, CA 91761, United States
Phone: (601) 213-4426
Email: info@benchchem.com

Contact our Ph.D. Support Team for a compatibility check