

Technical Support Center: Enhancing Metabolic Stability of Cyclopropyl-Containing Compounds

Author: BenchChem Technical Support Team. **Date:** May 2026

Compound of Interest

Compound Name: 2-Cyclopropylpyrimidin-5-amine

CAS No.: 1152519-69-1

Cat. No.: B1373474

[Get Quote](#)

Welcome to the technical support center for researchers, scientists, and drug development professionals. This guide provides in-depth troubleshooting advice and answers to frequently asked questions regarding the metabolic stability of drug candidates containing a cyclopropyl moiety. The unique physicochemical properties of the cyclopropyl group make it a valuable tool in medicinal chemistry, but its metabolic fate can be complex and, at times, problematic. This resource is designed to help you navigate these challenges effectively.

Part 1: Frequently Asked Questions (FAQs)

This section addresses common questions about the role and metabolic fate of cyclopropyl groups in drug molecules.

Q1: Why are cyclopropyl groups so frequently used in drug design?

A1: The cyclopropyl group is a popular motif in medicinal chemistry for several strategic reasons. Its rigid, three-membered ring structure imparts conformational constraint on molecules, which can lock a compound into its bioactive conformation, enhancing binding potency and selectivity for its biological target[1][2]. The strained C-C bonds have enhanced p-

character, and the C-H bonds are shorter and stronger than those in typical alkanes[3][4][5]. This high C-H bond dissociation energy often makes the cyclopropyl group resistant to oxidative metabolism by Cytochrome P450 (CYP) enzymes, thereby increasing a compound's metabolic stability and in vivo half-life[1][3][4][6].

Q2: I thought cyclopropyl groups were metabolic blockers. Are they ever unstable?

A2: While often used to block metabolism, the cyclopropyl group can itself be a site of metabolic liability, a phenomenon sometimes referred to as "metabolic switching." [7] This is particularly true for cyclopropylamines (a cyclopropyl ring attached to a nitrogen atom). This specific substructure is susceptible to oxidation by CYP enzymes, which can lead to bioactivation.[6][8] In some cases, even a simple cyclopropyl ring not attached to an amine can undergo unexpected oxidation, as has been observed in hepatocytes from multiple species.[6] Therefore, while advantageous, their stability is not guaranteed and must be experimentally verified.

Q3: What are the primary metabolic pathways for cyclopropyl-containing compounds?

A3: The metabolic pathways depend heavily on the chemical context of the cyclopropyl group.

- **Intended Stability:** In many cases, the cyclopropyl group successfully serves as a metabolic shield. For example, in the drug pitavastatin, the cyclopropyl group diverts metabolism away from the highly polymorphic CYP3A4 enzyme.[6]
- **Oxidative Ring Opening (Bioactivation):** For cyclopropylamines, a common and problematic pathway involves CYP-mediated oxidation. This process can begin with a hydrogen atom abstraction or single-electron transfer (SET) at the nitrogen, forming a radical intermediate. [9][10][11] This is often followed by rapid ring-opening of the strained cyclopropane, creating a reactive carbon-centered radical that can lead to the formation of reactive metabolites.[9][12]
- **Direct Oxidation:** In some instances, the cyclopropyl ring itself can be hydroxylated, though this is less common than the bioactivation of cyclopropylamines.[6]

Q4: What is "bioactivation," and why is it a concern for cyclopropylamines?

A4: Bioactivation is the metabolic conversion of a relatively inert compound into a chemically reactive metabolite. For cyclopropylamines, CYP-mediated oxidation can generate ring-opened intermediates that are highly reactive.^{[6][9]} These reactive species can covalently bind to cellular macromolecules like proteins, which is a potential mechanism for idiosyncratic drug toxicity, such as the hepatotoxicity observed with the fluoroquinolone antibiotic trovafloxacin.^{[6][13]} A key indicator of bioactivation is the formation of glutathione (GSH) conjugates in in vitro assays, as GSH is a cellular nucleophile that "traps" and detoxifies reactive electrophiles.^{[6][9]}

Part 2: Troubleshooting Guides

This section provides structured guidance for specific experimental challenges you may encounter.

Guide 1: High Clearance in Microsomal Stability Assays

Problem: My new cyclopropyl-containing compound shows a short half-life (high clearance) in my in vitro liver microsome stability assay. How do I determine if the cyclopropyl group is the source of the instability?

Scientific Rationale: High clearance indicates that the compound is rapidly metabolized by the enzymes present in the liver microsomes, primarily Cytochrome P450s.^{[14][15]} The first step in addressing this is to identify the exact site of metabolism (the "metabolic soft spot"). While the cyclopropyl group is often stable, it can be a site of unexpected oxidation.^[6] Identifying the metabolites formed is crucial for guiding structural modifications.^{[7][16]}

Troubleshooting Workflow & Solution:

- **Conduct a Metabolite Identification (MetID) Study:** Incubate a higher concentration of your compound with liver microsomes (human, rat, etc.) fortified with the necessary cofactor, NADPH.^[17]
- **Analyze Samples with LC-MS/MS:** Use high-resolution mass spectrometry to analyze the incubation mixture at different time points. Look for new peaks that correspond to potential metabolites. The most common modification is oxidation, which results in a mass increase of 16 Da (+O) or 14 Da (+O, -H₂).
- **Interpret the Mass Shift:**

- +16 Da (Hydroxylation): This is a very common metabolic transformation. It could occur on the cyclopropyl ring itself or elsewhere on the molecule. Tandem MS (MS/MS) fragmentation can help pinpoint the location of the hydroxyl group.
- Ring Opening Products: If the cyclopropylamine moiety is the liability, you may detect ring-opened products, such as aldehydes or ketones, or their further oxidized carboxylic acid derivatives.^[12] These will have specific mass shifts that can be calculated based on the parent structure.
- Confirm with Control Incubations: Run parallel incubations without NADPH. The absence of metabolite formation in these control wells confirms that the metabolism is CYP-dependent.

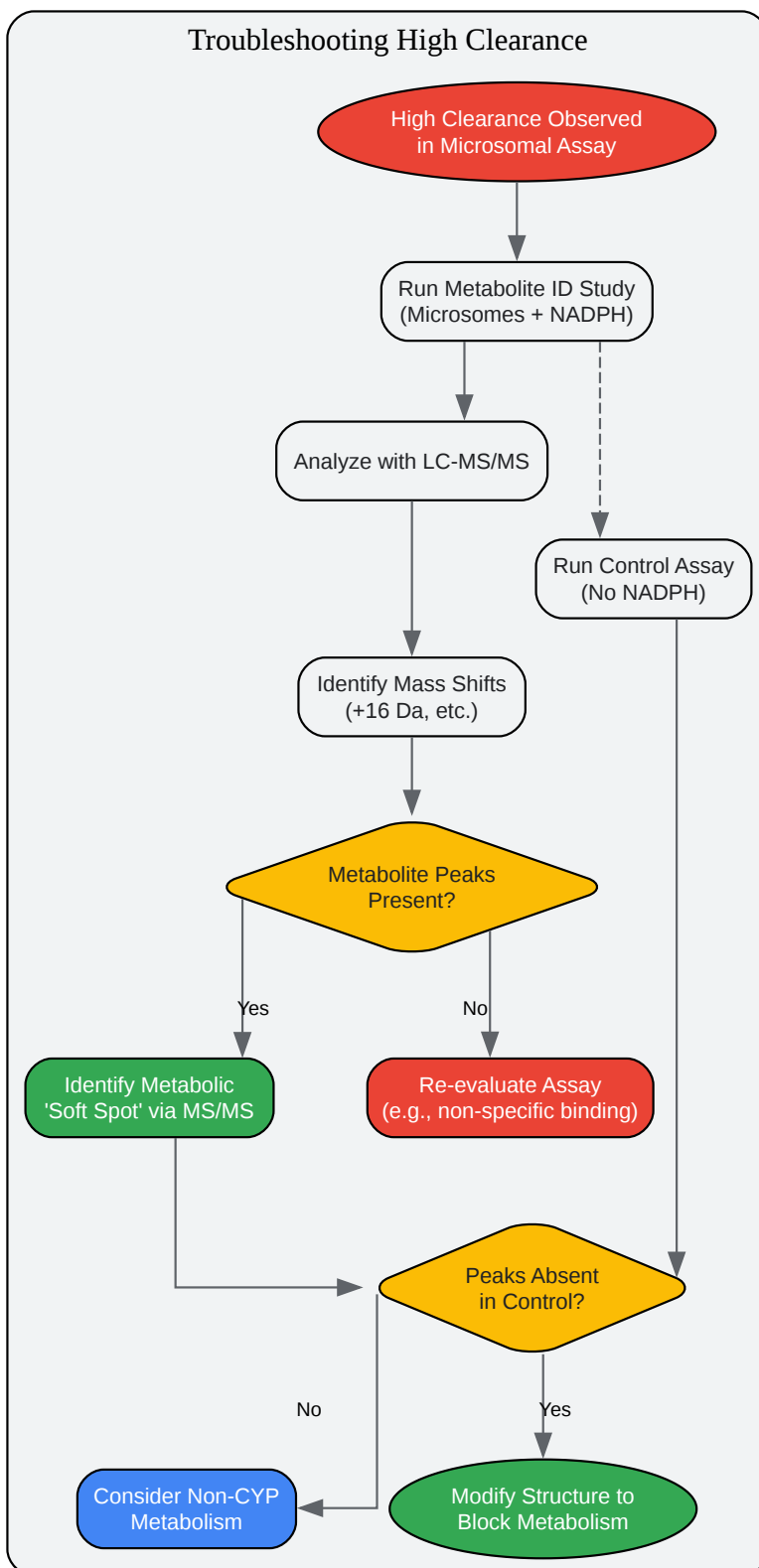

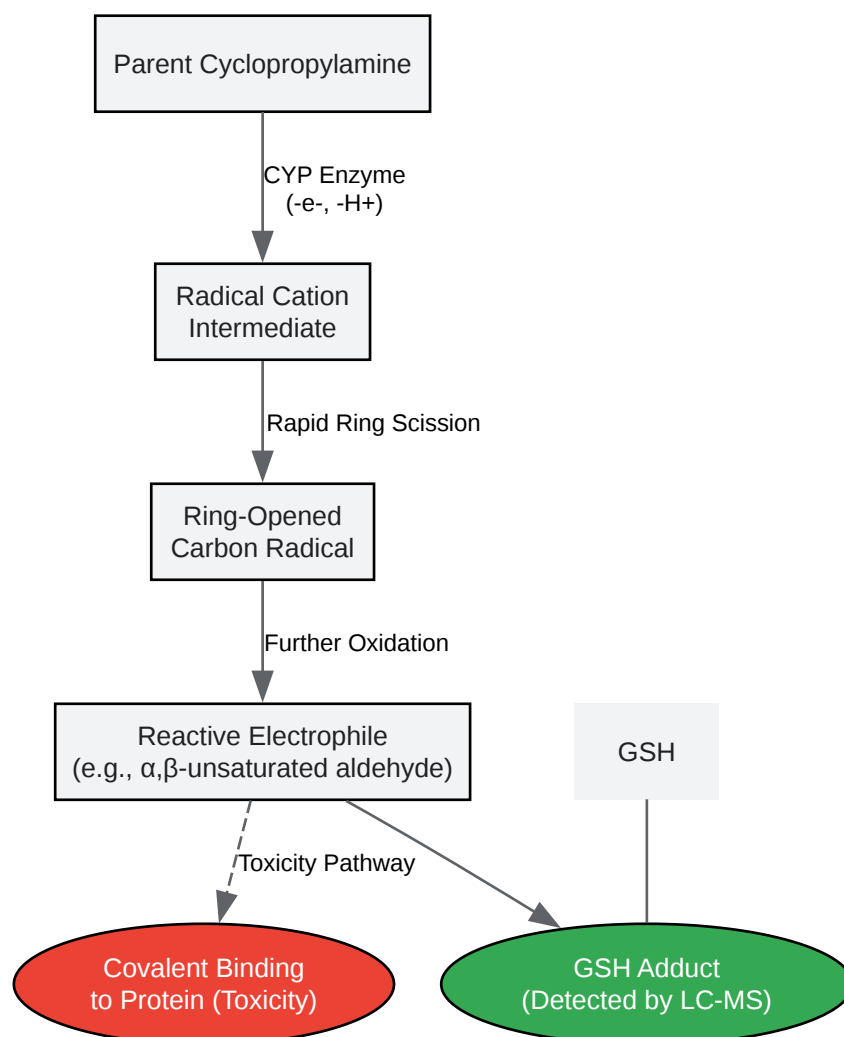

[Click to download full resolution via product page](#)

Caption: Bioactivation pathway of cyclopropylamines.

Guide 3: Strategies for Enhancing Metabolic Stability

Problem: I have confirmed that the cyclopropyl moiety in my compound is a metabolic liability. What structural modifications can I make to improve stability while trying to maintain potency?

Scientific Rationale: Once the metabolic soft spot is identified, the goal is to modify the structure to prevent that specific metabolic reaction without negatively impacting the compound's desired pharmacological activity (i.e., maintaining a good Structure-Activity Relationship, SAR). Several strategies have proven effective in blocking cyclopropyl group metabolism. [18] Solutions and Design Strategies:

The table below summarizes common and effective modification strategies based on published case studies.

Strategy	Modification Example	Rationale & Key Considerations	Potential Outcome
1. Steric Hindrance	Add a methyl group to the cyclopropyl ring adjacent to the amine.	The methyl group can sterically block the CYP enzyme's access to the site of oxidation. [6] This had the added benefit of increasing potency in one reported case by accessing a lipophilic pocket. [6]	Improved metabolic stability; potential for increased potency.
2. Isosteric Replacement	Replace the cyclopropyl ring with a gem-dimethyl group.	This is a classic strategy. The gem-dimethyl group can mimic the steric profile of the cyclopropyl ring but lacks the ring strain and susceptibility to radical ring-opening. This successfully averted bioactivation in a series of Hepatitis C inhibitors. [6][9]	Averted bioactivation; maintained or slightly altered potency.

3. Lowering Basicity (pKa)	Introduce an adjacent electron-withdrawing group to lower the pKa of the amine.	Lowering the basicity of the nitrogen can make it less susceptible to the initial single-electron transfer or hydrogen abstraction step by CYP enzymes. This was used in the optimization of risdiplam. [6]	Reduced metabolic liability; can also mitigate off-target effects like hERG channel inhibition. [6]
----------------------------	---	---	---

4. Deuteration	Replace a metabolically labile C-H bond with a C-D bond.	The Carbon-Deuterium bond is stronger than the Carbon-Hydrogen bond (Kinetic Isotope Effect). This can slow the rate of CYP-mediated hydrogen abstraction, thus reducing the rate of metabolism. [18]	Slower metabolism, increased half-life. The effect can be modest to significant.
----------------	--	---	--

Important Consideration: Any modification can impact the compound's overall properties (potency, solubility, permeability). It is crucial to test each new analogue across a full suite of ADME and pharmacology assays. Solving one problem can sometimes introduce another (e.g., metabolic switching). [7]

Part 3: Key Experimental Protocols

Protocol 1: In Vitro Metabolic Stability Assessment using Liver Microsomes

Objective: To determine the in vitro half-life ($t_{1/2}$) and intrinsic clearance (CL_{int}) of a test compound. [14][19] Materials:

- Pooled liver microsomes (human, rat, etc.)
- Test compound stock solution (e.g., 10 mM in DMSO)
- Phosphate buffer (e.g., 100 mM, pH 7.4)
- NADPH regenerating system (e.g., NADP⁺, glucose-6-phosphate, G6P-dehydrogenase)
- Positive control compound with known metabolic fate (e.g., Verapamil, Testosterone)
- Acetonitrile with internal standard (for quenching)
- 96-well plates, LC-MS/MS system

Methodology:

- Preparation: Thaw microsomes on ice. Prepare a microsomal suspension in phosphate buffer (e.g., to 0.5 mg/mL final protein concentration).
- Incubation Mixture (Part A): In a 96-well plate, add the microsomal suspension. Add the test compound to achieve the desired final concentration (typically 1 μ M). Pre-incubate the plate at 37°C for 5-10 minutes.
- Initiate Reaction (Part B): Prepare the NADPH regenerating system solution in phosphate buffer. To initiate the metabolic reaction, add the NADPH solution to the wells containing the compound and microsomes. Mix well. This is your T=0 time point.
- Time Points: Incubate the plate at 37°C. At designated time points (e.g., 0, 5, 15, 30, 60 minutes), take an aliquot from the reaction well and add it to a separate 96-well plate containing cold acetonitrile with an internal standard. This quenches the reaction.
- Control Incubations: Run parallel incubations without the NADPH regenerating system to control for non-CYP-mediated degradation or non-specific binding.
- Sample Processing: Once all time points are collected, centrifuge the quenched plate to pellet the precipitated protein.

- **LC-MS/MS Analysis:** Transfer the supernatant to a new plate for analysis. Quantify the remaining parent compound at each time point by comparing its peak area to the internal standard's peak area.
- **Data Analysis:** Plot the natural log of the percentage of the parent compound remaining versus time. The slope of the linear regression line (k) is used to calculate the half-life ($t_{1/2} = 0.693 / k$) and intrinsic clearance (CL_{int}). [20]

Protocol 2: Reactive Metabolite Trapping with Glutathione (GSH)

Objective: To detect the formation of chemically reactive metabolites by trapping them with glutathione.

Materials:

- Same materials as Protocol 1.
- Glutathione (GSH), reduced form.
- (Optional) N-acetylcysteine (NAC) as an alternative trapping agent.

Methodology:

- **Setup:** The experimental setup is very similar to the standard metabolic stability assay.
- **Add Trapping Agent:** Prepare the microsomal incubation mixture as described in Protocol 1. Before adding the test compound, add GSH to the mixture to a final concentration of 1-5 mM.
- **Initiate and Incubate:** Add the test compound (typically at a higher concentration, e.g., 10-50 μ M, to aid detection) and initiate the reaction with NADPH. Incubate for a fixed time, usually 60 minutes at 37°C.
- **Quench and Process:** Quench the reaction with cold acetonitrile containing an internal standard and process the samples as described above.

- LC-MS/MS Analysis for Adducts: Analyze the supernatant by LC-MS/MS. In addition to monitoring the parent compound, perform a parent ion scan or neutral loss scan to specifically search for the mass of the potential GSH adduct. The mass of a GSH-adducted compound will be the parent mass + 305.1 Da.
- Data Interpretation: The presence of a peak corresponding to the GSH adduct confirms the formation of a reactive metabolite. The structure of this adduct can be further investigated using MS/MS fragmentation to confirm the site of conjugation. [9]

References

- Hypha Discovery. (n.d.). Metabolism of cyclopropyl groups. Hypha Discovery Blogs. [Link]
- Wessjohann, L. A., Brandt, W., & Thiemann, T. (2003). Biosynthesis and Metabolism of Cyclopropane Rings in Natural Compounds. *Chemical Reviews*, 103(4), 1625–1648. [Link]
- Scientific Update. (2020). The Cyclopropyl Group in Medicinal Chemistry. [Link]
- Nuvisan. (n.d.). Advanced in vitro metabolic stability assays for drug discovery. [Link]
- Talele, T. T. (2016). The "Cyclopropyl Fragment" is a Versatile Player that Frequently Appears in Preclinical/Clinical Drug Molecules. *Journal of Medicinal Chemistry*, 59(19), 8712–8756. [Link]
- Gajula, S. N., et al. (2021). In vitro Metabolic Stability of Drugs and Applications of LC-MS in Metabolite Profiling. ResearchGate. [Link]
- Talele, T. T. (2016). The "Cyclopropyl Fragment" is a Versatile Player that Frequently Appears in Preclinical/Clinical Drug Molecules. *Journal of Medicinal Chemistry*, 59(19), 8712–8756. [Link]
- Soglia, J. R., et al. (2016). Bioactivation of cyclopropyl rings by P450: an observation encountered during the optimisation of a series of hepatitis C virus NS5B inhibitors. *Xenobiotica*, 46(1), 19-30. [Link]
- Creative Bioarray. (n.d.). In Vitro Metabolic Stability. [Link]

- Unnamed Publisher. (n.d.). The Crucial Role of Cyclopropane Derivatives in Modern Drug Discovery. [[Link](#)]
- Frontage Laboratories. (n.d.). Metabolic Stability. [[Link](#)]
- ResearchGate. (2016). The “Cyclopropyl Fragment” is a Versatile Player that Frequently Appears in Preclinical/Clinical Drug Molecules | Request PDF. [[Link](#)]
- Admescope. (n.d.). Services for in vitro Metabolism research. [[Link](#)]
- Wang, Y., et al. (2017). Suicide Inhibition of Cytochrome P450 Enzymes by Cyclopropylamines via a Ring-Opening Mechanism: Proton-Coupled Electron Transfer Makes a Difference. *Frontiers in Chemistry*, 5, 3. [[Link](#)]
- ResearchGate. (2003). Biosynthesis and Metabolism of Cyclopropane Rings in Natural Compounds | Request PDF. [[Link](#)]
- Groves, J. T. (2006). The Enzymatic Chemistry of Cyclopropane, Epoxide, and Aziridine Biosynthesis. *Chemical Reviews*, 106(8), 3247-3269. [[Link](#)]
- ResearchGate. (2005). Cyclopropylamine inactivation of cytochromes P450: Role of metabolic intermediate complexes. [[Link](#)]
- Cerny, M. A., & Hanzlik, R. P. (2005). Cyclopropylamine inactivation of cytochromes P450: role of metabolic intermediate complexes. *Journal of medicinal chemistry*, 48(12), 3991-7. [[Link](#)]
- ResearchGate. (2020). Examples of Pharmacologically Active Compounds Containing the Cyclopropylamine Group and Bioactivation by P450 and MAO Enzymes. [[Link](#)]
- Newcomb, M., et al. (2003). Cyclopropyl Containing Fatty Acids as Mechanistic Probes for Cytochromes P450. *Journal of the American Chemical Society*, 125(20), 6064-5. [[Link](#)]
- Wang, Y., et al. (2017). Suicide Inhibition of Cytochrome P450 Enzymes by Cyclopropylamines via a Ring-Opening Mechanism: Proton-Coupled Electron Transfer Makes a Difference. *Frontiers in Chemistry*, 5, 3. [[Link](#)]

- Wang, Y., et al. (2017). Suicide Inhibition of Cytochrome P450 Enzymes by Cyclopropylamines via a Ring-Opening Mechanism: Proton-Coupled Electron Transfer Makes a Difference. *Frontiers in Chemistry*, 5, 3. [[Link](#)]
- ResearchGate. (2017). Improvements to metabolic stability through cyclopropyl modification. [[Link](#)]
- Hanzlik, R. P., & Tullman, R. H. (1982). Suicidal inactivation of cytochrome P-450 by cyclopropylamines. Evidence for cation-radical intermediates. *Journal of the American Chemical Society*, 104(7), 2048–2050. [[Link](#)]
- Kamel, A. (2010). Improving the decision-making process in the structural modification of drug candidates Part I: Enhancing Metabolic Stability. *NEDMDG*. [[Link](#)]
- Kalgutkar, A. S., et al. (2005). A Comprehensive Listing of Bioactivation Pathways of Organic Functional Groups. *Current Drug Metabolism*, 6(3), 161-225. [[Link](#)]
- Parvattaneni, N., et al. (2008). In Vitro Metabolism of a Model Cyclopropylamine to Reactive Intermediate: Insights into Trovafloxacin-Induced Hepatotoxicity. *Chemical Research in Toxicology*, 21(2), 436-444. [[Link](#)]
- Wessjohann, L. A., Brandt, W., & Thiemann, T. (2003). Biosynthesis and Metabolism of Cyclopropane Rings in Natural Compounds. *Chemical Reviews*, 103(4), 1625–1648. [[Link](#)]
- Sonti, R., et al. (n.d.). Metabolic Stability. *Pharma Focus Asia*. [[Link](#)]
- Barr, D. A., et al. (2024). Tackling metabolism issues in drug discovery with in silico methods. *AZoNetwork*. [[Link](#)]
- D'Souza, C., & Lavasanifar, A. (2018). Strategies to Enhance Metabolic Stabilities. *Methods in Molecular Biology*, 1786, 1-18. [[Link](#)]
- ResearchGate. (2021). Enhancement of metabolic stability with structural modifications. [[Link](#)]
- Wessjohann, L. A., Brandt, W., & Thiemann, T. (2003). Biosynthesis and metabolism of cyclopropane rings in natural compounds. *Chemical Reviews*, 103(4), 1625-1647. [[Link](#)]

- Unnamed Publisher. (2024). How to Conduct an In Vitro Metabolic Stability Study. [[Link](#)]
- Lilla, E. A., et al. (2023). Structural, Biochemical, and Bioinformatic Basis for Identifying Radical SAM Cyclopropyl Synthases. ACS Chemical Biology, 18(1), 136-146. [[Link](#)]

Need Custom Synthesis?

BenchChem offers custom synthesis for rare earth carbides and specific isotopic labeling.

Email: info@benchchem.com or [Request Quote Online](#).

Sources

- 1. nbinno.com [nbinno.com]
- 2. researchgate.net [researchgate.net]
- 3. scientificupdate.com [scientificupdate.com]
- 4. The "Cyclopropyl Fragment" is a Versatile Player that Frequently Appears in Preclinical/Clinical Drug Molecules - PubMed [pubmed.ncbi.nlm.nih.gov]
- 5. pubs.acs.org [pubs.acs.org]
- 6. hyphadiscovery.com [hyphadiscovery.com]
- 7. nedmdg.org [nedmdg.org]
- 8. researchgate.net [researchgate.net]
- 9. Bioactivation of cyclopropyl rings by P450: an observation encountered during the optimisation of a series of hepatitis C virus NS5B inhibitors - PubMed [pubmed.ncbi.nlm.nih.gov]
- 10. Suicide Inhibition of Cytochrome P450 Enzymes by Cyclopropylamines via a Ring-Opening Mechanism: Proton-Coupled Electron Transfer Makes a Difference - PMC [pmc.ncbi.nlm.nih.gov]
- 11. pubs.acs.org [pubs.acs.org]
- 12. researchgate.net [researchgate.net]
- 13. pubs.acs.org [pubs.acs.org]
- 14. dda.creative-bioarray.com [dda.creative-bioarray.com]
- 15. Metabolic Stability • Frontage Laboratories [frontagelab.com]

- [16. news-medical.net \[news-medical.net\]](#)
- [17. researchgate.net \[researchgate.net\]](#)
- [18. pharmafocusasia.com \[pharmafocusasia.com\]](#)
- [19. nuvisan.com \[nuvisan.com\]](#)
- [20. How to Conduct an In Vitro Metabolic Stability Study \[synapse.patsnap.com\]](#)
- To cite this document: BenchChem. [Technical Support Center: Enhancing Metabolic Stability of Cyclopropyl-Containing Compounds]. BenchChem, [2026]. [Online PDF]. Available at: [<https://www.benchchem.com/product/b1373474/docs#technical-support-center-enhancing-metabolic-stability-of-cyclopropyl-containing-compounds>]

Disclaimer & Data Validity:

The information provided in this document is for Research Use Only (RUO) and is strictly not intended for diagnostic or therapeutic procedures. While BenchChem strives to provide accurate protocols, we make no warranties, express or implied, regarding the fitness of this product for every specific experimental setup.

Technical Support: The protocols provided are for reference purposes. Unsure if this reagent suits your experiment?

Need Industrial/Bulk Grade? [Request Custom Synthesis Quote](#)

BenchChem

Our mission is to be the trusted global source of essential and advanced chemicals, empowering scientists and researchers to drive progress in science and industry.

Contact

Address: 3281 E Guasti Rd

Ontario, CA 91761, United States

Phone: (601) 213-4426

Email: info@benchchem.com

Contact our Ph.D. Support Team for a compatibility check