

Part 1: Structural Significance & Pharmacophore Utility

Author: BenchChem Technical Support Team. **Date:** May 2026

Compound of Interest

Compound Name: *[5-Chloro-6-(propan-2-yloxy)pyridin-3-yl]methanol*

CAS No.: 1247194-55-3

Cat. No.: B1528378

[Get Quote](#)

In drug design, the specific placement of a chlorine atom at the C5 position of a pyridine ring, adjacent to a C6-functional handle, serves three critical roles:

- **Metabolic Blocking:** The C5 position of pyridine is electronically electron-rich (meta to nitrogen) and is a primary site for oxidative metabolism by Cytochrome P450 enzymes (specifically CYP3A4). Installing a chlorine atom here blocks this "soft spot," significantly extending the half-life () of the molecule.
- **pKa Modulation:** Pyridine is a weak base (pKa ~5.2). An electron-withdrawing chlorine at C5 lowers the basicity of the ring nitrogen (approx. -1.5 pKa units), reducing the likelihood of hERG channel binding and improving membrane permeability by maintaining a higher fraction of the uncharged species at physiological pH.
- **Orthogonal Reactivity:** The chemical distinction between the C5 (meta, unactivated) and C6 (ortho, activated) positions allows for highly selective sequential functionalization. This "chemical orthogonality" is the cornerstone of its utility as a building block.

Part 2: Synthetic Access & Regioselectivity[2][3]

The synthesis of 5-chloro-6-substituted pyridines relies on differentiating the reactivity of halogenated precursors. The most common starting materials are 2,3-dichloropyridine or 2-bromo-3-chloropyridine (Note: IUPAC numbering prioritizes the heteroatom, so the user's "5-chloro-6-substituted" target often originates from 3-chloro-2-halo precursors).

The Reactivity Hierarchy

To synthesize these targets, one must exploit the electronic bias of the pyridine ring:

- C6 (Position 2 in IUPAC): Adjacent to the ring nitrogen. The inductive effect (-I) and mesomeric stabilization of the Meisenheimer complex make this position highly susceptible to Nucleophilic Aromatic Substitution () and Oxidative Addition (in Pd-catalysis).
- C5 (Position 3 in IUPAC): Meta to the ring nitrogen. It lacks resonance activation and is sterically shielded if C6 is substituted. The C-Cl bond here is robust and typically survives conditions that functionalize C6.

Decision Tree: Functionalization Strategy

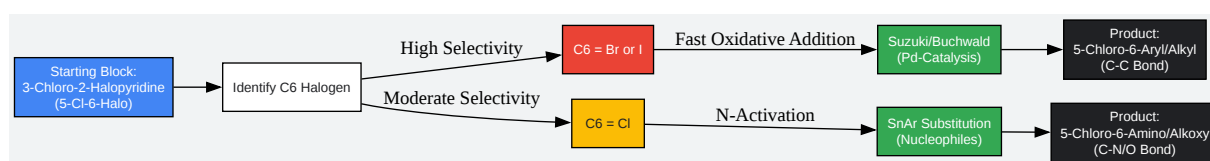

[Click to download full resolution via product page](#)

Figure 1: Reactivity logic for differentiating C5 and C6 positions. The C6-Halogen is kinetically favored for both Pd-catalyzed and nucleophilic attacks.

Part 3: Experimental Protocols

The following protocols are designed for high fidelity and reproducibility. They assume the use of 2-bromo-3-chloropyridine to maximize regioselectivity at the C6 (C2-IUPAC) position.

Protocol A: Regioselective Suzuki-Miyaura Coupling (C6-Arylation)

Objective: To install an aryl group at C6 while preserving the C5-Cl bond for later elaboration.

Reagents:

- Substrate: 2-Bromo-3-chloropyridine (1.0 equiv)
- Boronic Acid: Arylboronic acid (1.1 equiv)
- Catalyst:
(3-5 mol%)
- Base:
(2.0 M aq. solution, 3.0 equiv)
- Solvent: 1,4-Dioxane (0.2 M concentration)

Methodology:

- Degassing: Charge a reaction vial with the substrate, boronic acid, and Pd catalyst. Seal and purge with Argon for 5 minutes. Why: Oxygen promotes homocoupling of boronic acids and poisons the Pd(0) species.
- Solvation: Add degassed 1,4-Dioxane and the aqueous base solution via syringe.
- Thermal Activation: Heat the mixture to 60–80°C.
 - Critical Control Point: Do NOT exceed 90°C. Higher temperatures may activate the C5-Cl bond, leading to bis-coupling or polymerization. The C6-Br bond undergoes oxidative addition readily at lower temperatures.

- Work-up: Monitor by LCMS. Upon consumption of the bromide (typically 2-4 hours), cool to RT, dilute with EtOAc, and wash with water/brine.
- Purification: Flash column chromatography (Hexane/EtOAc).

Protocol B: Regioselective Amination (C6-Amination)

Objective: To install an amine at C6 using the activating influence of the pyridine nitrogen.

Reagents:

- Substrate: 2,3-Dichloropyridine (1.0 equiv)
- Nucleophile: Primary or Secondary Amine (1.2 equiv)
- Base:
(2.0 equiv) or
(1.5 equiv)
- Solvent: DMSO or NMP (Polar aprotic solvents accelerate)

Methodology:

- Setup: Dissolve 2,3-dichloropyridine in DMSO (0.5 M). Add the amine and base.^[2]
- Reaction: Heat to 100–120°C in a sealed tube.
 - Mechanistic Insight: The reaction proceeds via a Meisenheimer intermediate. The transition state is stabilized by the ring nitrogen (ortho-effect). The C3-Cl (C5 position) does not offer this stabilization, ensuring exclusive substitution at C2 (C6).
- Quench: Pour into crushed ice/water. The product often precipitates as a solid.
- Isolation: Filtration or extraction with DCM.

Part 4: Data & Visualization[4]

Workflow Visualization: Sequential Functionalization

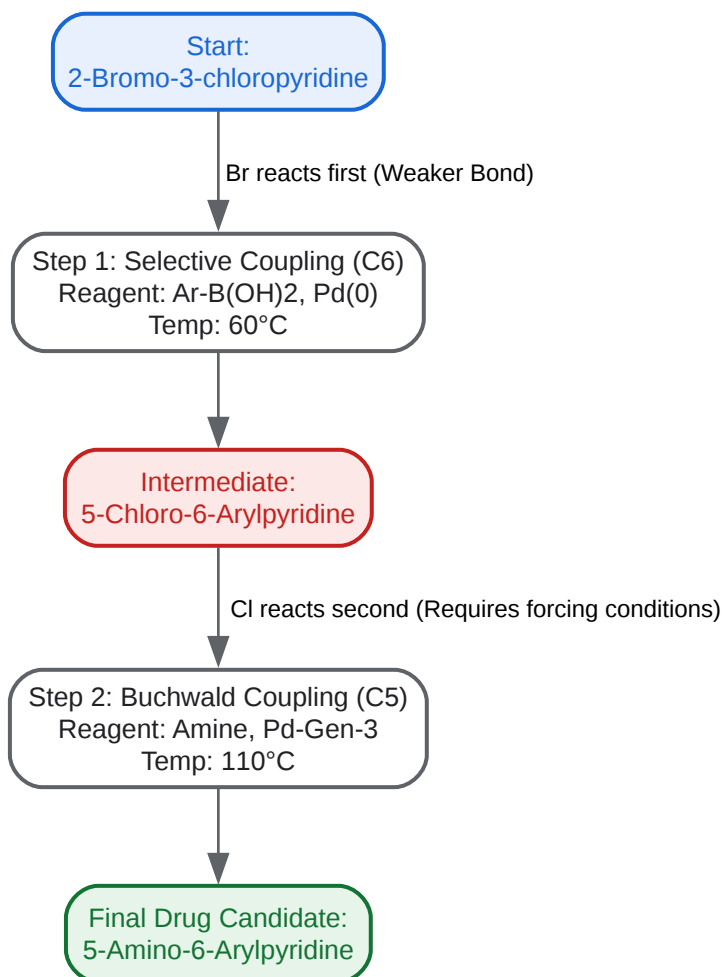

[Click to download full resolution via product page](#)

Figure 2: Sequential workflow demonstrating the "Orthogonal Reactivity" principle. The C6-Br is used for carbon-carbon bond formation under mild conditions, followed by C5-Cl functionalization under forcing conditions.

Table 1: Comparative Reactivity of Halogenated Pyridines

Position (User/IUPAC)	Substituent	Electronic Environment	Reactivity (Pd-Cat)	Reactivity ()
C6 / C2	Bromine (Br)	Activated (to N)	High (Fast O.A.)	High (Meisenheimer stab.)
C6 / C2	Chlorine (Cl)	Activated (to N)	Moderate	High
C5 / C3	Chlorine (Cl)	Deactivated (to N)	Low (Slow O.A.)	Inert

References

- Lutz, M. R., et al. "Site-Selective Suzuki–Miyaura Coupling of Heteroaryl Halides – Understanding the Trends for Pharmaceutically Important Classes." *Chemical Science*, vol. 8, no. 2, 2017. [Link](#)
- Schlosser, M., et al. "Regioselective Functionalization of Chloropyridines." *Journal of Organic Chemistry*, vol. 70, no. 6, 2005. [Link](#)
- Li, J. J. "Pyridine and Benzo Derivatives." *Heterocyclic Chemistry in Drug Discovery*, Wiley, 2013. [Link](#)
- Blakemore, D. C., et al. "Organic Synthesis Provides Opportunities to Transform Drug Discovery." *Nature Chemistry*, vol. 10, 2018, pp. 383–394. [Link](#)
- BenchChem Application Note. "2,3-Dichloropyridine as a Versatile Precursor for Medicinal Chemistry Scaffolds." [Link](#)

Need Custom Synthesis?

BenchChem offers custom synthesis for rare earth carbides and specific isotopic labeling.

Email: info@benchchem.com or [Request Quote Online](#).

Sources

- [1. pdf.benchchem.com \[pdf.benchchem.com\]](https://pdf.benchchem.com)
- [2. pdf.benchchem.com \[pdf.benchchem.com\]](https://pdf.benchchem.com)
- To cite this document: BenchChem. [Part 1: Structural Significance & Pharmacophore Utility]. BenchChem, [2026]. [Online PDF]. Available at: [\[https://www.benchchem.com/product/b1528378/docs#part-1-structural-significance-pharmacophore-utility\]](https://www.benchchem.com/product/b1528378/docs#part-1-structural-significance-pharmacophore-utility)

Disclaimer & Data Validity:

The information provided in this document is for Research Use Only (RUO) and is strictly not intended for diagnostic or therapeutic procedures. While BenchChem strives to provide accurate protocols, we make no warranties, express or implied, regarding the fitness of this product for every specific experimental setup.

Technical Support: The protocols provided are for reference purposes. Unsure if this reagent suits your experiment?

Need Industrial/Bulk Grade? [Request Custom Synthesis Quote](#)

BenchChem

Our mission is to be the trusted global source of essential and advanced chemicals, empowering scientists and researchers to drive progress in science and industry.

Contact

Address: 3281 E Guasti Rd
Ontario, CA 91761, United States
Phone: (601) 213-4426
Email: info@benchchem.com

[Contact our Ph.D. Support Team for a compatibility check](#)

