

Orthogonal Protecting Group Strategies for Diamines: A Technical Comparison Guide

Author: BenchChem Technical Support Team. **Date:** May 2026

Compound of Interest

Compound Name: *1-Boc-6-Cbz-octahydropyrrolo[3,4-b]pyridine*
CAS No.: 1385694-44-9
Cat. No.: B1528153

[Get Quote](#)

Introduction: The Symmetry Challenge

In medicinal chemistry and linker design, diamines (e.g., ethylenediamine, piperazine, trans-1,4-cyclohexanediamine) are ubiquitous scaffolds. The core synthetic challenge is desymmetrization: differentiating two chemically equivalent nitrogen atoms to allow for sequential, selective functionalization.

Achieving this requires orthogonal protecting group strategies—pairs of protecting groups (PGs) that can be removed via completely distinct mechanisms (e.g., acid vs. base vs. metal catalysis) without affecting the other. This guide moves beyond basic textbook definitions to provide field-proven strategies, stability data, and robust experimental protocols for the selective manipulation of diamines.

Strategic Pairings: Causality & Application

The choice of an orthogonal pair is dictated by the stability requirements of the subsequent synthetic steps.

A. The "Classic" Pair: Boc / Cbz (Acid / Hydrogenolysis)

- Mechanism: tert-Butyloxycarbonyl (Boc) is acid-labile; Benzyloxycarbonyl (Cbz) is cleaved by catalytic hydrogenolysis (

/Pd-C) or strong Lewis acids.
- Why use it: Ideal for solution-phase synthesis where no intermediate metal catalysis is required. Cbz is robust against the acidic conditions used to remove Boc (TFA/DCM), and Boc is stable to the neutral conditions of hydrogenation.
- Limitation: Cbz cannot be used if the molecule contains sulfur (catalyst poisoning) or alkenes (reduction risk).

B. The "SPPS" Standard: Boc / Fmoc (Acid / Base)

- Mechanism: Boc is acid-labile; Fluorenylmethyloxycarbonyl (Fmoc) is base-labile (piperidine).
- Why use it: The gold standard for Solid Phase Peptide Synthesis (SPPS). It allows for the construction of polyamines or peptide-mimetics without touching the side-chain protection of the growing scaffold.
- Causality: The dibenzofulvene byproduct of Fmoc cleavage is reactive; scavengers are required, but the basic conditions leave Boc completely intact.

C. The "High-Fidelity" Pair: Fmoc / Alloc (Base / Pd(0))

- Mechanism: Fmoc is base-labile; Allyloxycarbonyl (Alloc) is cleaved by Palladium(0)-catalyzed allyl transfer.
- Why use it: When both acid and base sensitivity are issues for the payload.^[1] Alloc cleavage is essentially neutral (using tributyltin hydride or dimedone as scavengers).
- Field Insight: This is the preferred strategy for "on-resin" modification of lysine side chains in complex peptides.

D. The "Side-Chain" Specialist: Dde / Boc (Hydrazine / Acid)

- Mechanism: Dde (1-(4,4-dimethyl-2,6-dioxocyclohexylidene)ethyl) is cleaved by hydrazine; Boc is acid-labile.[2]
- Why use it: Dde is orthogonal to both Fmoc and Boc, making it perfect for branching strategies where a third point of diversity is needed on a diamine scaffold.

Comparative Analysis: Stability & Deprotection Matrix

The following table summarizes the stability of common amine protecting groups against standard deprotection reagents.

Protecting Group	TFA (Acid)	Piperidine (Base)	H ₂ /Pd-C (Red)	Pd(PPh ₃) ₄ (Allyl)	Hydrazine
Boc	Cleaved	Stable	Stable	Stable	Stable
Fmoc	Stable	Cleaved	Stable	Stable	Cleaved*
Cbz (Z)	Stable	Stable	Cleaved	Stable	Stable
Alloc	Stable	Stable	Stable	Cleaved	Stable
Dde	Stable	Stable	Stable	Stable	Cleaved

*Note: Standard hydrazine treatment (2%) can cleave Fmoc.[3] For Dde removal in the presence of Fmoc, a specialized hydroxylamine/imidazole protocol is required.

Visualizing the Strategy

The following diagram illustrates the decision logic for selecting a protecting group strategy based on the substrate's sensitivity.

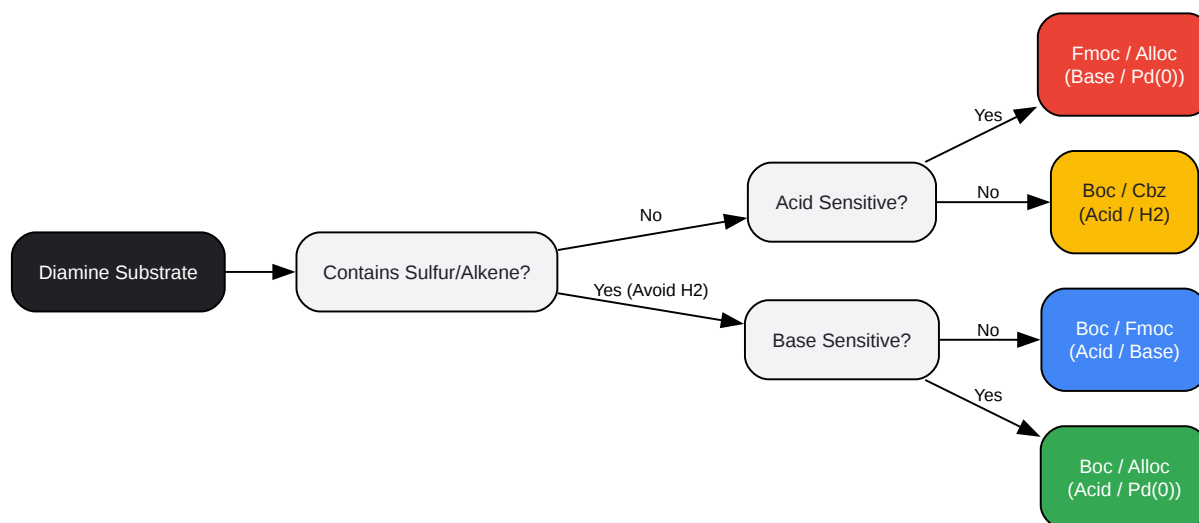

Figure 1: Decision Tree for Orthogonal Protecting Group Selection

[Click to download full resolution via product page](#)

Experimental Protocols

Protocol A: Selective Mono-Boc Protection (The "HCl Salt" Method)

Differentiation of symmetrical diamines is statistically difficult. The "HCl Salt" method forces the diamine into a mono-protonated state, drastically increasing selectivity for mono-protection over di-protection compared to direct addition.

Scope: Symmetrical diamines (e.g., Piperazine, trans-1,4-cyclohexanediamine). Source: Adapted from Ha et al. [1].[4][5]

- Stoichiometry: 1.0 eq Diamine : 1.0 eq HCl : 1.0 eq Boc₂O.
- Preparation: Dissolve the diamine (10 mmol) in 50% aqueous Methanol (30 mL).
- Acidification: Add HCl (10 mmol) dropwise (using 1M aqueous HCl or HCl in dioxane). Stir for 15 minutes. Crucial: This creates a statistical distribution where the dominant species is

the mono-ammonium salt.

- Protection: Add a solution of Di-tert-butyl dicarbonate (Boc₂O, 10 mmol) in Methanol (10 mL) dropwise over 20 minutes.
- Reaction: Stir at room temperature for 1 hour.
- Workup:
 - The reaction mixture will contain mono-Boc, di-Boc, and unreacted diamine.
 - Basify the solution to pH >12 using 4M NaOH.
 - Extract with Dichloromethane (DCM) (3 x 30 mL).
 - Purification Note: The unreacted diamine remains in the aqueous phase (highly polar). The di-Boc byproduct is non-polar. The mono-Boc product is moderately polar and is extracted.
- Yield: Typically 65–85% mono-protected product.

Protocol B: Selective Boc Deprotection in Presence of Cbz (FeCl₃ Method)

Traditional acid cleavage (TFA) works, but Lewis acid catalysis offers a milder alternative that prevents potential benzyl cation migration or side reactions.

Scope: Substrates containing both Boc and Cbz groups. Source: Adapted from Mandal et al. [2].[6]

- Reagents: Anhydrous FeCl₃ (Iron(III) chloride).
- Procedure:
 - Dissolve the N-Boc, N'-Cbz protected diamine (1 mmol) in Dichloromethane (DCM, 5 mL).
 - Add anhydrous FeCl₃ (1.5 mmol, 1.5 eq).

- Stir at room temperature. Monitor by TLC (Time varies: 15 min to 2 hours).
- Mechanism: The Iron(III) coordinates to the carbamate carbonyl oxygen, facilitating the fragmentation of the tert-butyl group.
- Workup:
 - Quench with water.^[7]
 - Wash the organic layer with saturated NaHCO₃ (to remove iron salts and any free acid).
 - Dry over Na₂SO₄ and concentrate.
- Result: Quantitative removal of Boc; Cbz remains >98% intact.

Protocol C: Alloc Deprotection (Palladium Catalysis)

Used when orthogonal removal is required without using acid or base.

Scope: Peptides or sensitive scaffolds with Fmoc/Boc groups present.^{[1][3][8][9]} Source: Standard Novabiochem Protocols ^[3].

- Reagents: Pd(PPh₃)₄ (Tetrakis(triphenylphosphine)palladium(0)), Phenylsilane (PhSiH₃) as scavenger.
- Procedure:
 - Dissolve substrate in dry DCM under Argon.
 - Add Phenylsilane (20 eq) (Acts as the allyl acceptor).
 - Add Pd(PPh₃)₄ (0.1 eq).
 - Stir at Room Temperature for 30 minutes.
- Workup:
 - The reaction turns black (Pd precipitation).

- Filter through a Celite pad to remove Palladium.
- Concentrate and purify via column chromatography.[\[10\]](#)

Advanced Workflow: Synthesis of a Hetero-Bifunctional Linker

The following diagram illustrates a real-world workflow converting a symmetrical diamine into a linker with two different "warheads" using the strategies described above.

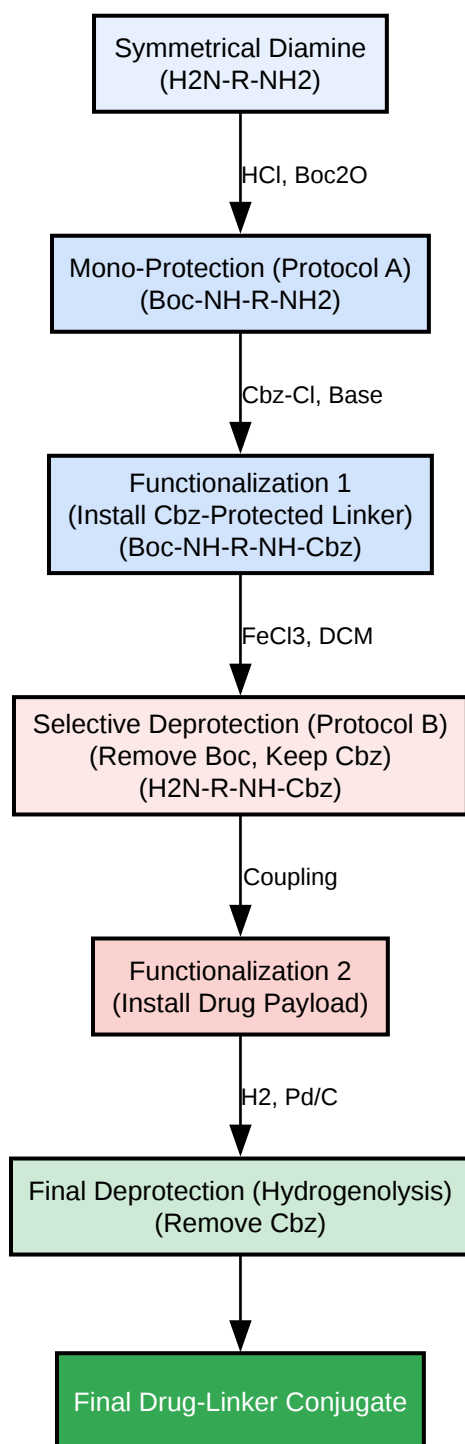

Figure 2: Orthogonal Workflow for Hetero-Bifunctional Linker Synthesis

[Click to download full resolution via product page](#)

References

- Selective Mono-Boc Protection: Lee, D. W., Ha, H. J., & Lee, W. K. (2007). "Selective Mono-BOC Protection of Diamines." *Synthetic Communications*. Available at:
- FeCl₃ Selective Deprotection: Mandal, P. K., & McMurray, J. S. (2007). "FeCl₃-mediated liberation of tert-butoxycarbonyl-protected amines." *The Journal of Organic Chemistry*. Available at:
- Alloc Deprotection Strategy: Merck/Sigma-Aldrich. "Alloc Protecting Group Strategies in SPPS." Available at:
- Dde/ivDde Orthogonality: Aapptec. "Removal of Dde and ivDde Protecting Groups." Available at:

Need Custom Synthesis?

BenchChem offers custom synthesis for rare earth carbides and specific isotopic labeling.

Email: info@benchchem.com or [Request Quote Online](#).

Sources

- [1. Orthogonal Deprotection Strategy of Fmoc Provides Improved Synthesis of Sensitive Peptides: Application to Z-Arg-Lys-AOMK - PMC \[pmc.ncbi.nlm.nih.gov\]](#)
- [2. pubs.rsc.org \[pubs.rsc.org\]](#)
- [3. peptide.com \[peptide.com\]](#)
- [4. General Method for Selective Mono-Boc Protection of Diamines and Thereof \[scielo.org.mx\]](#)
- [5. researchgate.net \[researchgate.net\]](#)
- [6. researchgate.net \[researchgate.net\]](#)
- [7. redalyc.org \[redalyc.org\]](#)
- [8. researchgate.net \[researchgate.net\]](#)
- [9. Fmoc Amino Acids for SPPS - AltaBioscience \[altabioscience.com\]](#)
- [10. FeCl₃-Mediated Side Chain Modification of Aspartic Acid- and Glutamic Acid-Containing Peptides on a Solid Support - PMC \[pmc.ncbi.nlm.nih.gov\]](#)

- To cite this document: BenchChem. [Orthogonal Protecting Group Strategies for Diamines: A Technical Comparison Guide]. BenchChem, [2026]. [Online PDF]. Available at: [<https://www.benchchem.com/product/b1528153/docs#orthogonal-protecting-group-strategies-for-diamines-a-technical-comparison-guide>]

Disclaimer & Data Validity:

The information provided in this document is for Research Use Only (RUO) and is strictly not intended for diagnostic or therapeutic procedures. While BenchChem strives to provide accurate protocols, we make no warranties, express or implied, regarding the fitness of this product for every specific experimental setup.

Technical Support: The protocols provided are for reference purposes. Unsure if this reagent suits your experiment?

Need Industrial/Bulk Grade? [Request Custom Synthesis Quote](#)

BenchChem

Our mission is to be the trusted global source of essential and advanced chemicals, empowering scientists and researchers to drive progress in science and industry.

Contact

Address: 3281 E Guasti Rd
Ontario, CA 91761, United States
Phone: (601) 213-4426
Email: info@benchchem.com

[Contact our Ph.D. Support Team for a compatibility check](#)