

Comparative Guide: Mass Spectrometry Fragmentation Patterns of Thiane-1,1-dione

Author: BenchChem Technical Support Team. **Date:** April 2026

Compound of Interest

Compound Name: 3-(Chloromethyl)-1λ6-thiane-1,1-dione

CAS No.: 1481109-28-7

Cat. No.: B1528472

[Get Quote](#)

Executive Summary

Thiane-1,1-dione (Pentamethylene sulfone) represents a critical structural motif in drug development, often appearing as a stable metabolic end-product of sulfur-containing pharmaceuticals (e.g., thiane or thiane-1-oxide derivatives).^[1] Accurate identification of this moiety is essential for metabolite profiling and impurity characterization.

This guide provides a technical comparison of the Electron Ionization (EI) fragmentation patterns of thiane-1,1-dione against its reduced analogs, thiane-1-oxide and thiane. Unlike its precursors, thiane-1,1-dione exhibits a "stealth" fragmentation behavior where the dominant spectral features arise from the hydrocarbon backbone following the extrusion of sulfur dioxide (SO₂), often obscuring the sulfur functionality.

Part 1: Compound Profile & Structural Context

Feature	Thiane-1,1-dione	Thiane-1-oxide	Thiane
Structure	Cyclic Sulfone	Cyclic Sulfoxide	Cyclic Sulfide
Formula			
MW	134.19 Da	118.19 Da	102.20 Da
Oxidation State	S(VI)	S(IV)	S(II)
Key Stability	High thermal stability; chemically inert	Thermally labile (sulfoxide pyrolysis)	Prone to oxidation

Part 2: Fragmentation Mechanics & Comparative Analysis

The "Hydrocarbon Masquerade" of Thiane-1,1-dione

The mass spectrum of thiane-1,1-dione is characterized by a weak molecular ion (

) and a base peak derived from the complete loss of the sulfonyl group. This behavior contrasts sharply with sulfoxides and sulfides, which retain the sulfur atom in major fragments.

- Primary Mechanism (

Extrusion): Upon electron impact (70 eV), the molecular ion (m/z 134) undergoes a rapid cheletropic-like elimination of neutral

(64 Da). This generates a vibrationally excited pentamethylene diradical cation (

, m/z 70).

- Secondary Decay: The nascent

ion behaves identically to the molecular ion of cyclopentane or 1-pentene, fragmenting further into

(m/z 42) and

(m/z 55).

Comparative Diagnostic Ions

The following table contrasts the diagnostic ions required to distinguish the sulfone from its analogs.

Ion Type	Thiane-1,1-dione (Sulfone)	Thiane-1-oxide (Sulfoxide)	Thiane (Sulfide)
Molecular Ion	m/z 134 (Weak, <5%)	m/z 118 (Moderate)	m/z 102 (Strong)
Base Peak	m/z 42 or 55 (Hydrocarbon)	m/z 101 () or 41	m/z 102 or 87 ()
Diagnostic Loss 1	M - 64 () m/z 70	M - 17 () m/z 101	M - 28 () m/z 74
Diagnostic Loss 2	M - 28 (Not primary)	M - 16 () m/z 102	M - 15 () m/z 87
Spectral Signature	Resembles hydrocarbon spectrum below m/z 70. [1] [2] [3] [4] [5] [6] [7] [8] [9] [10]	Distinctive "Sulfoxide Cut" (M-17).	Distinctive Sulfide pattern (M, M-15, M-28).

Mechanistic Pathways (Graphviz Visualization)

The following diagram illustrates the divergent fragmentation pathways. The sulfone pathway is dominated by the ejection of the heteroatom group, whereas the sulfoxide pathway involves hydrogen rearrangement and radical loss.

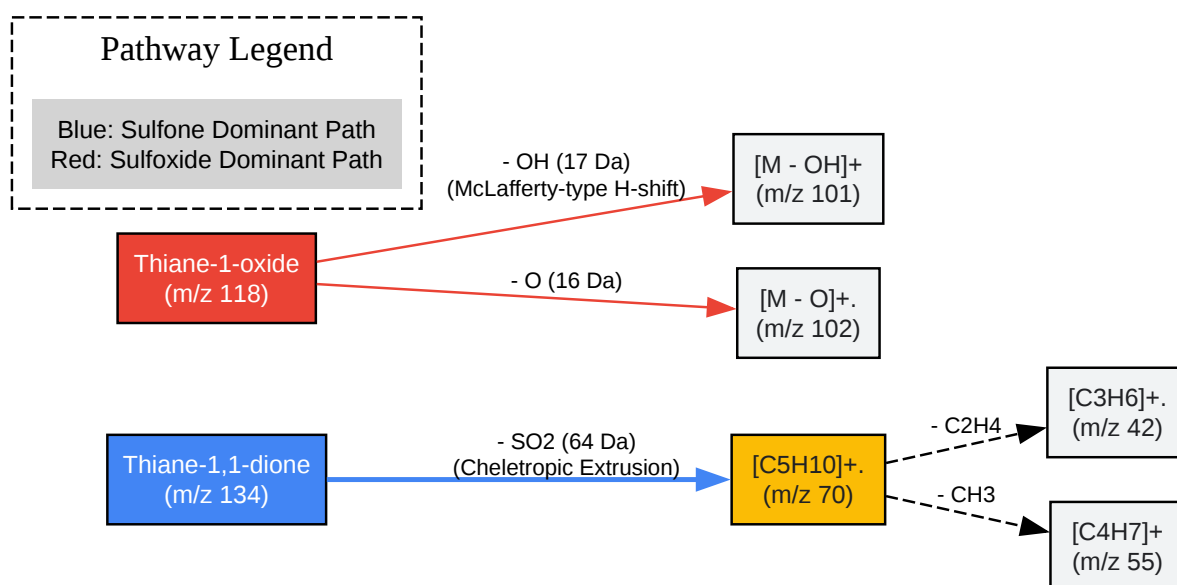

[Click to download full resolution via product page](#)

Caption: Divergent fragmentation logic: Sulfones eject the sulfur core (Blue), while Sulfoxides retain sulfur but lose oxygen/hydroxyl groups (Red).[8]

Part 3: Experimental Protocol for Identification

To reliably distinguish thiane-1,1-dione from isobaric interferences or structural isomers, the following GC-MS protocol is recommended. This protocol ensures sufficient thermal energy for the characteristic

extrusion without inducing pre-source thermal degradation.

Step-by-Step Methodology

- Sample Preparation:
 - Dissolve 1 mg of sample in 1 mL of Dichloromethane (DCM) or Ethyl Acetate.

- Note: Avoid protic solvents like methanol if derivatization is not intended, although sulfones are generally stable.
- GC Parameters (Agilent 7890/5977 or equivalent):
 - Column: DB-5MS or HP-5MS (30m x 0.25mm x 0.25 μ m).
 - Carrier Gas: Helium at 1.0 mL/min (Constant Flow).
 - Inlet Temperature: 250°C (Splitless mode recommended for trace analysis).
 - Temperature Program:
 - Hold at 50°C for 1 min.
 - Ramp 20°C/min to 280°C.
 - Hold 3 min.
 - Rationale: Thiane-1,1-dione is polar; a mid-polarity column ensures sharp peak shape.
- MS Parameters (Source Conditions):
 - Ionization: Electron Ionization (EI) at 70 eV.
 - Source Temperature: 230°C.
 - Mass Range: Scan m/z 35 – 300.
 - Solvent Delay: 3.0 min (to protect filament).
- Data Validation (Self-Check):
 - Check 1: Locate peak at retention time corresponding to intermediate polarity.
 - Check 2: Verify presence of m/z 134 (Molecular Ion).[\[11\]](#) It should be small but visible.
 - Check 3: Confirm Base Peak is NOT m/z 134. If m/z 134 is the base peak, suspect a different isomer or soft ionization artifact.

- Check 4: Confirm absence of m/z 117 (M-17) or m/z 119 (M-15). The presence of these suggests sulfoxide contamination.

References

- NIST Mass Spectrometry Data Center. (2023). Mass Spectrum of Pentamethylene Sulfone (Thiane-1,1-dione). NIST Chemistry WebBook, SRD 69. [\[Link\]](#)
- Vainiotalo, P., et al. (1990). Mass Spectral Study of Some Stereoisomeric 2-Thioxo- and 2-Oxo-perhydro-1,3-benzoxazines. *Acta Chemica Scandinavica*, 44, 165–169.[\[9\]](#) (Provides comparative context for cyclic sulfone/sulfoxide fragmentation mechanics). [\[Link\]](#)
- Klagkou, K., et al. (2003). Fragmentation pathways of sulphonamides under electrospray tandem mass spectrometric conditions. *Rapid Communications in Mass Spectrometry*, 17(21), 2373-2379. (Discusses the fundamental extrusion mechanism relevant to sulfone moieties). [\[Link\]](#)
- Budzikiewicz, H., et al. (1967). *Mass Spectrometry of Organic Molecules*. Holden-Day.

Need Custom Synthesis?

BenchChem offers custom synthesis for rare earth carbides and specific isotopic labeling.

Email: info@benchchem.com or [Request Quote Online](#).

Sources

- 1. hetpdbnavi.nagahama-i-bio.ac.jp [hetpdbnavi.nagahama-i-bio.ac.jp]
- 2. The unanticipated loss of SO₂ from sulfonamides in collision-induced dissociation - PubMed [pubmed.ncbi.nlm.nih.gov]
- 3. US20230338337A1 - Biomarkers for cancer therapy using mdm2 antagonists - Google Patents [patents.google.com]
- 4. patentimages.storage.googleapis.com [patentimages.storage.googleapis.com]
- 5. researchgate.net [researchgate.net]
- 6. WO1997049736A2 - Particles comprising amphiphilic copolymers, having a cross-linked shell domain and an interior core domain, useful for pharmaceutical and other applications -

[Google Patents \[patents.google.com\]](#)

- [7. WO2024038090A1 - Use of substituted benzoxazole and benzofuran compounds for the treatment and prevention of diseases associated with chronic fatigue, exhaustion and/or exertional intolerance - Google Patents \[patents.google.com\]](#)
- [8. scielo.br \[scielo.br\]](#)
- [9. scispace.com \[scispace.com\]](#)
- [10. researchgate.net \[researchgate.net\]](#)
- [11. lib3.dss.go.th \[lib3.dss.go.th\]](#)
- To cite this document: BenchChem. [Comparative Guide: Mass Spectrometry Fragmentation Patterns of Thiane-1,1-dione]. BenchChem, [2026]. [Online PDF]. Available at: [\[https://www.benchchem.com/product/b1528472/docs#comparative-guide-mass-spectrometry-fragmentation-patterns-of-thiane-1-1-dione\]](https://www.benchchem.com/product/b1528472/docs#comparative-guide-mass-spectrometry-fragmentation-patterns-of-thiane-1-1-dione)

Disclaimer & Data Validity:

The information provided in this document is for Research Use Only (RUO) and is strictly not intended for diagnostic or therapeutic procedures. While BenchChem strives to provide accurate protocols, we make no warranties, express or implied, regarding the fitness of this product for every specific experimental setup.

Technical Support: The protocols provided are for reference purposes. Unsure if this reagent suits your experiment?

Need Industrial/Bulk Grade? [Request Custom Synthesis Quote](#)

BenchChem

Our mission is to be the trusted global source of essential and advanced chemicals, empowering scientists and researchers to drive progress in science and industry.

Contact

Address: 3281 E Guasti Rd
Ontario, CA 91761, United States
Phone: (601) 213-4426
Email: info@benchchem.com

Contact our Ph.D. Support Team for a compatibility check