

Comparative Guide: 2-Isopropoxy vs. 6-Isopropoxy Pyridine Isomers in Drug Design

Author: BenchChem Technical Support Team. **Date:** May 2026

Compound of Interest

Compound Name: *[5-Chloro-6-(propan-2-yloxy)pyridin-3-yl]methanol*

CAS No.: 1247194-55-3

Cat. No.: B1528378

[Get Quote](#)

Executive Summary

In medicinal chemistry, the choice between a 2-isopropoxy and a 6-isopropoxy substituent on a 3-substituted pyridine scaffold is a strategic decision that impacts metabolic stability, solubility, and target engagement.

Feature	2-Isopropoxy Isomer (Ortho-like)	6-Isopropoxy Isomer (Para-like)
Steric Environment	High steric hindrance; often forces non-planar conformations.	Low steric hindrance; allows planar conformations.
Metabolic Stability	High: Sterically shields the ring nitrogen and C3 substituent; reduces N-oxidation.	Moderate/Low: Exposed to oxidative metabolism; prone to -dealkylation to 6-pyridone.
Solubility	Enhanced: "Ortho-effect" disrupts crystal packing, lowering MP and increasing solubility.	Standard: Tendency for better packing and higher crystallinity.
Synthetic Access	Difficult: SNAr is sluggish due to steric crowding from the C3 group.	Facile: SNAr proceeds rapidly with high yields.
Primary Utility	Improving solubility & metabolic stability; inducing conformational twist.	Extending pharmacophores; maximizing binding interactions.

Structural & Electronic Profiling

The "Ortho" vs. "Para" Effect

The fundamental difference lies in the proximity of the bulky isopropoxy group (

) to the functional handle at C3 (e.g., amide, carboxylic acid, amine).

- 2-Isopropoxy (The "Twisted" Isomer): The isopropyl group creates significant steric pressure against the C3 substituent. This often forces the C3 group out of the plane of the pyridine ring.
 - Consequence: This "twist" disrupts

-

stacking in the solid state, significantly lowering the melting point and improving thermodynamic solubility in aqueous media.

- Electronic: The oxygen lone pair donates into the ring, but the inductive withdrawal is felt strongly at the adjacent C3 position.
- 6-Isopropoxy (The "Planar" Isomer): The isopropoxy group is distal to the C3 substituent.
 - Consequence: The molecule retains a flatter conformation, facilitating crystal packing (lower solubility) but allowing for optimal binding in narrow enzyme pockets where width is restricted.

Diagram: Structural Divergence & Signaling

The following diagram illustrates the structural impact and downstream effects of selecting either isomer.

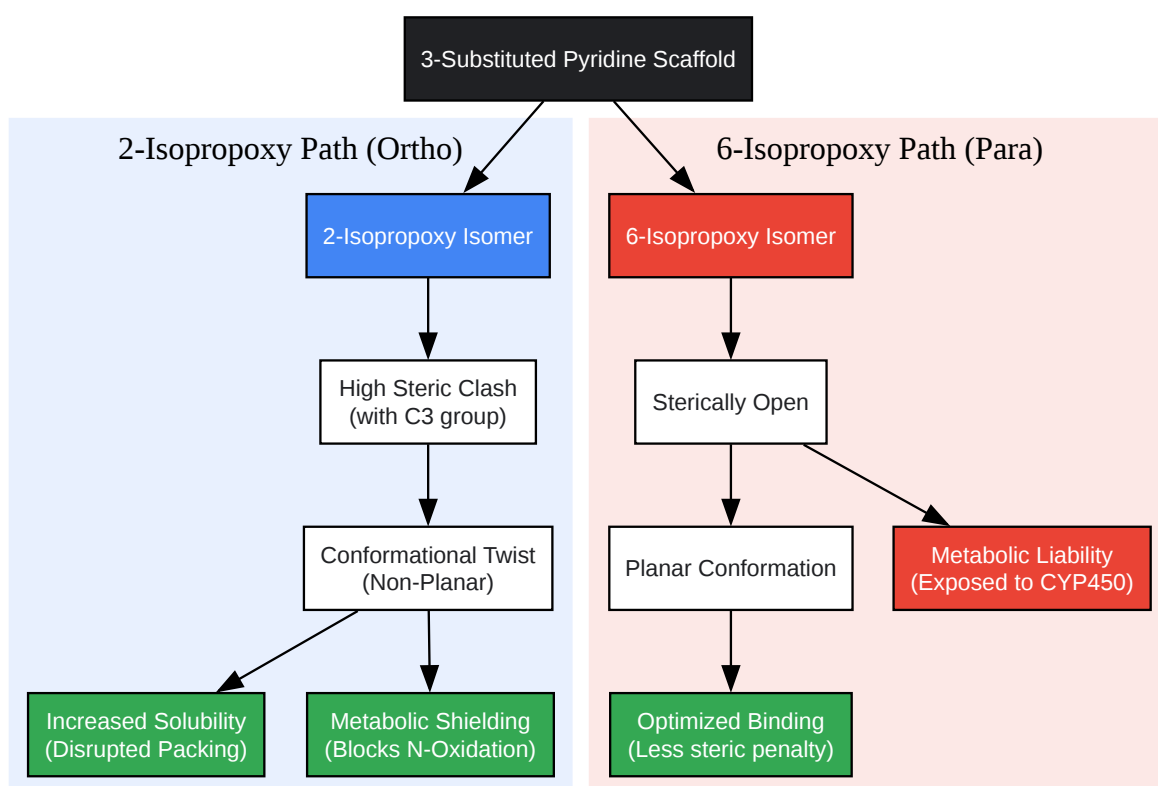

[Click to download full resolution via product page](#)

Figure 1: Decision tree showing the causal relationship between regiochemistry and physicochemical outcomes.

Metabolic Stability & Performance Data

Metabolic Soft Spots

The pyridine ring is susceptible to oxidation by Cytochrome P450 (CYP) enzymes. The position of the isopropoxy group dictates the primary clearance pathway.

- N-Oxidation: Pyridines are electron-deficient but can be oxidized at the nitrogen to form N-oxides.
 - 2-Isopropoxy:[1][2][3][4] The bulky isopropyl group effectively "masks" the nitrogen lone pair, drastically reducing N-oxide formation [1].
 - 6-Isopropoxy:[1][3][5] The nitrogen is exposed, making N-oxidation a major clearance pathway.
- O-Dealkylation: The isopropyl group itself can be hydroxylated and cleaved (O-dealkylation), leading to the formation of a pyridone.
 - 2-Isopropoxy:[1][2][3][4] While susceptible, the steric bulk of a C3 substituent can hinder the approach of CYP enzymes to the ether oxygen.
 - 6-Isopropoxy:[1][3][5] Highly exposed. Rapid O-dealkylation often converts the molecule to the corresponding 6-pyridone, which is usually inactive and rapidly excreted.

Comparative Data (Representative)

Based on SAR studies of nicotinic acid derivatives (e.g., GPR88 agonists [1]).[6]

Parameter	2-Isopropoxy Analog	6-Isopropoxy Analog
Microsomal Stability ()	> 60 min (High)	15 - 30 min (Low/Moderate)
Primary Metabolite	-dealkylated pyridone (Minor)	-oxide & -dealkylated pyridone (Major)
LogD (pH 7.4)	2.8 (Lower due to polarity exposure)	3.1 (Higher, planar packing)
Aqueous Solubility	High (>100 M)	Moderate (~20-50 M)

Experimental Protocols

A. Synthesis: Regioselective SNAr Reaction

The most common method to install the isopropoxy group is Nucleophilic Aromatic Substitution (SNAr) on a chloropyridine precursor.

Objective: Synthesize 2-isopropoxy-3-cyanopyridine vs. 6-isopropoxy-3-cyanopyridine.

Protocol 1: Synthesis of 6-Isopropoxy Isomer (Facile)

This reaction proceeds rapidly due to lack of steric hindrance.

- Reagents: 6-chloro-3-cyanopyridine (1.0 eq), Isopropanol (solvent/reactant), Cesium Carbonate (, 2.0 eq).
- Procedure:
 - Dissolve 6-chloro-3-cyanopyridine in anhydrous isopropanol (0.5 M).
 - Add

- Heat to 60°C for 2-4 hours.
- Observation: Reaction completes quickly.
- Workup: Filter salts, concentrate filtrate, purify via silica flash chromatography (Hex/EtOAc).

Protocol 2: Synthesis of 2-Isopropoxy Isomer (Challenging)

This reaction requires higher energy due to steric clash with the C3-cyano group.

- Reagents: 2-chloro-3-cyanopyridine (1.0 eq), Sodium Isopropoxide (NaOiPr, 1.5 eq) pre-formed, Anhydrous THF or DMF.
- Procedure:
 - Note: Using in iPrOH is often insufficient. Stronger nucleophile (alkoxide) is required.
 - Dissolve 2-chloro-3-cyanopyridine in THF (0.5 M).
 - Add NaOiPr solution slowly at 0°C (to prevent side reactions), then warm to Reflux (66°C) or 100°C (if DMF) for 12-24 hours.
 - Risk:[1] Prolonged heating can lead to the "N-alkyl" side product (N-isopropyl-2-pyridone) via thermal rearrangement [2].
- Workup: Aqueous quench, extraction with EtOAc. Careful separation of the O-alkyl product from trace N-alkyl byproduct is required.

B. Diagram: Synthetic Workflow

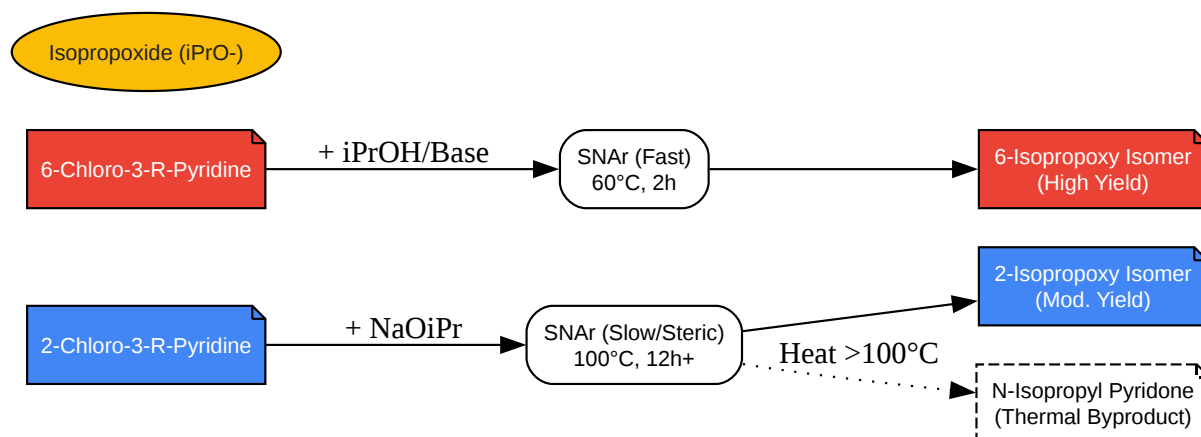

[Click to download full resolution via product page](#)

Figure 2: Synthetic pathways highlighting the kinetic difficulty and byproduct risk associated with the 2-isomer.

References

- Jin, C., et al. (2014). "Improvement of the Metabolic Stability of GPR88 Agonist RTI-13951–33: Design, Synthesis, and Biological Evaluation." *ACS Chemical Neuroscience*, 5(7), 576–587. [\[Link\]](#)
- Spivey, A. C., & Arseniyadis, S. (2004). "Nucleophilic Aromatic Substitution of Pyridines." *Angewandte Chemie International Edition*, 43(41), 5436–5441. [\[Link\]](#)
- Meanwell, N. A. (2011). "Fluorine and Fluorinated Motifs in the Design and Application of Bioisosteres for Drug Design." *Journal of Medicinal Chemistry*, 61(2), 582-612. (Discusses metabolic blocking of pyridine rings). [\[Link\]](#)

Need Custom Synthesis?

BenchChem offers custom synthesis for rare earth carbides and specific isotopic labeling.

Email: info@benchchem.com or [Request Quote Online](#).

Sources

- [1. dokumen.pub \[dokumen.pub\]](#)
- [2. researchgate.net \[researchgate.net\]](#)
- [3. WO2020005935A1 - Glucose uptake inhibitors - Google Patents \[patents.google.com\]](#)
- [4. espace.library.uq.edu.au \[espace.library.uq.edu.au\]](#)
- [5. escholarship.org \[escholarship.org\]](#)
- [6. Improvement of the Metabolic Stability of GPR88 Agonist RTI-13951–33: Design, Synthesis, and Biological Evaluation - PMC \[pmc.ncbi.nlm.nih.gov\]](#)
- To cite this document: BenchChem. [Comparative Guide: 2-Isopropoxy vs. 6-Isopropoxy Pyridine Isomers in Drug Design]. BenchChem, [2026]. [Online PDF]. Available at: [\[https://www.benchchem.com/product/b1528378/docs#comparative-guide-2-isopropoxy-vs-6-isopropoxy-pyridine-isomers-in-drug-design\]](https://www.benchchem.com/product/b1528378/docs#comparative-guide-2-isopropoxy-vs-6-isopropoxy-pyridine-isomers-in-drug-design)

Disclaimer & Data Validity:

The information provided in this document is for Research Use Only (RUO) and is strictly not intended for diagnostic or therapeutic procedures. While BenchChem strives to provide accurate protocols, we make no warranties, express or implied, regarding the fitness of this product for every specific experimental setup.

Technical Support: The protocols provided are for reference purposes. Unsure if this reagent suits your experiment?

Need Industrial/Bulk Grade? [Request Custom Synthesis Quote](#)

BenchChem

Our mission is to be the trusted global source of essential and advanced chemicals, empowering scientists and researchers to drive progress in science and industry.

Contact

Address: 3281 E Guasti Rd

Ontario, CA 91761, United States

Phone: (601) 213-4426

Email: info@benchchem.com

Contact our Ph.D. Support Team for a compatibility check