

Application Notes and Protocols for Studying Fatty-Acid Metabolism with Iodinated Tracers

Author: BenchChem Technical Support Team. **Date:** December 2025

Compound of Interest

Compound Name: Methyl 13-iodotridecanoate

Cat. No.: B15279452

[Get Quote](#)

For Researchers, Scientists, and Drug Development Professionals

Application Notes

Iodinated fatty acid tracers are powerful tools for investigating fatty acid metabolism in both in vitro and in vivo settings. These analogs of natural fatty acids, where a carbon atom is substituted with an iodine isotope (commonly ^{123}I), allow for non-invasive tracking and quantification of fatty acid uptake, oxidation, and esterification. Their primary application lies in the field of cardiology for myocardial imaging, but their use is expanding into oncology and other metabolic research areas.^{[1][2][3][4]}

There are two main classes of iodinated fatty acid tracers:

- Straight-chain iodinated fatty acids: These tracers, such as 15-(p-iodophenyl)pentadecanoic acid (IPPA), are metabolized by β -oxidation. Their clearance rate from a tissue is indicative of the rate of fatty acid oxidation.^{[1][5]}
- Branched-chain iodinated fatty acids: Tracers like 15-(p-iodophenyl)-3-R,S-methylpentadecanoic acid (BMIPP) have a methyl group that inhibits β -oxidation.^{[4][6]} This leads to their intracellular trapping and accumulation, primarily reflecting fatty acid uptake and esterification into complex lipids.^{[4][6]}

The choice of tracer depends on the specific metabolic process being investigated. For studying fatty acid oxidation, a straight-chain tracer is more appropriate, while for assessing

fatty acid uptake and storage, a branched-chain tracer is the preferred choice. These tracers are particularly useful for single-photon emission computed tomography (SPECT) imaging.[1]
[2]

Signaling Pathways in Fatty Acid Metabolism

The uptake and subsequent metabolic fate of fatty acids are tightly regulated by a complex network of signaling pathways. A key player in fatty acid uptake is the transmembrane protein CD36, which facilitates the transport of long-chain fatty acids into the cell. Downstream, the peroxisome proliferator-activated receptors (PPARs) are a family of nuclear receptors that act as master regulators of lipid metabolism, controlling the expression of genes involved in fatty acid uptake, activation, and oxidation.

Below are diagrams illustrating the CD36-mediated fatty acid uptake pathway and a simplified overview of the PPAR signaling pathway.

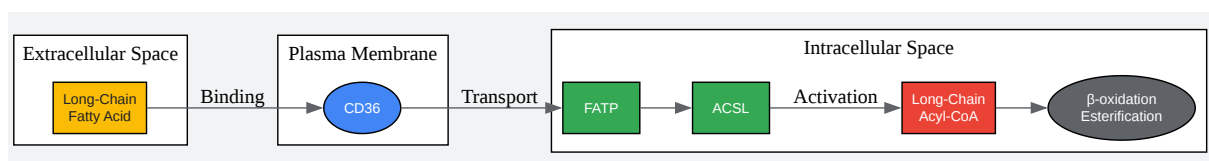

[Click to download full resolution via product page](#)

Caption: CD36-mediated fatty acid uptake pathway.

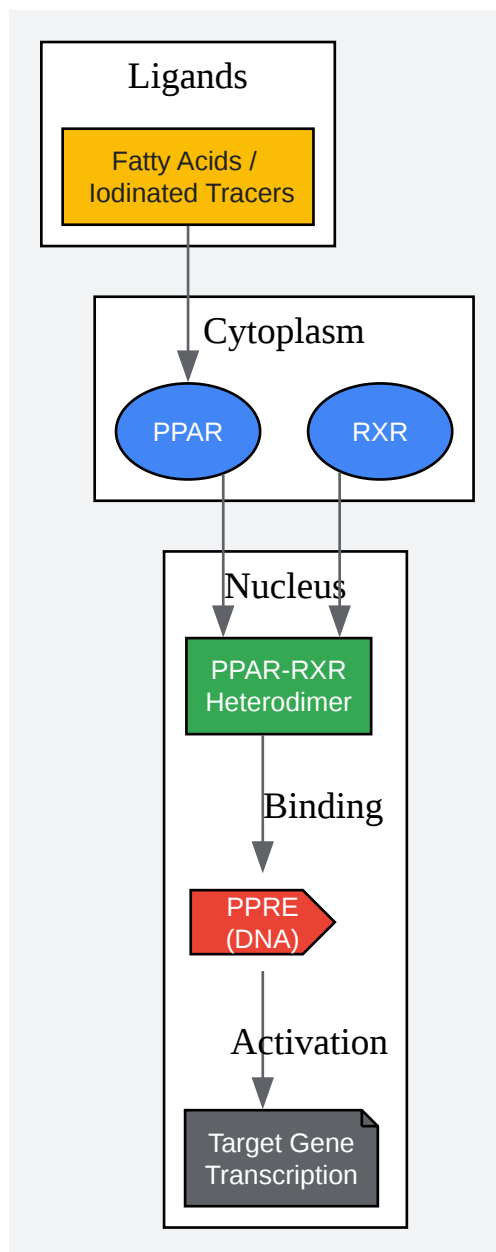

[Click to download full resolution via product page](#)

Caption: Simplified PPAR signaling pathway.

Experimental Protocols

In Vitro Protocol: Iodinated Fatty Acid Uptake in Cultured Cardiomyocytes

This protocol describes the measurement of iodinated fatty acid (e.g., ¹²³I-BMIPP) uptake in cultured cardiomyocytes.

Materials:

- Cultured cardiomyocytes (e.g., neonatal rat ventricular myocytes or H9c2 cells)
- Plating medium (e.g., DMEM with 10% FBS)
- Serum-free medium
- ¹²³I-BMIPP
- Fatty acid-free bovine serum albumin (BSA)
- Phosphate-buffered saline (PBS)
- Cell lysis buffer (e.g., RIPA buffer)
- Gamma counter
- Protein assay kit (e.g., BCA assay)

Procedure:

- Cell Culture: Plate cardiomyocytes in 12-well plates and culture until they reach desired confluency.
- Preparation of Tracer Solution: Prepare a working solution of ¹²³I-BMIPP complexed with fatty acid-free BSA in serum-free medium. The final concentration of ¹²³I-BMIPP will need to be optimized but a starting point of 37 kBq/mL can be used.
- Cell Treatment:
 - Aspirate the plating medium and wash the cells twice with warm PBS.
 - Pre-incubate the cells with serum-free medium for 1 hour at 37°C.
 - Remove the serum-free medium and add the ¹²³I-BMIPP working solution to each well.
 - Incubate for various time points (e.g., 5, 15, 30, 60 minutes) at 37°C.

- Uptake Termination and Cell Lysis:
 - To stop the uptake, aspirate the tracer solution and wash the cells three times with ice-cold PBS.
 - Add cell lysis buffer to each well and incubate on ice for 15 minutes.
 - Scrape the cells and collect the lysate.
- Quantification:
 - Measure the radioactivity in an aliquot of the cell lysate using a gamma counter to determine the amount of tracer uptake.
 - Use another aliquot of the cell lysate to determine the total protein concentration using a protein assay kit.
- Data Analysis: Express the tracer uptake as counts per minute per milligram of protein (CPM/mg protein) or as a percentage of the total added radioactivity.

In Vivo Protocol: Biodistribution of Iodinated Fatty Acid in a Rat Model of Myocardial Ischemia

This protocol outlines a procedure for assessing the biodistribution of an iodinated fatty acid tracer in a rat model of myocardial ischemia.

Materials:

- Male Wistar rats (250-300g)
- Anesthetics (e.g., isoflurane)
- Surgical instruments
- ¹²³I-BMIPP
- Saline solution

- Gamma counter
- Organ balance

Procedure:

- Animal Model: Induce myocardial ischemia by ligating the left anterior descending (LAD) coronary artery. Sham-operated animals will serve as controls.
- Tracer Injection:
 - After a desired period of ischemia (e.g., 24 hours), anesthetize the rat.
 - Inject a known amount of ^{123}I -BMIPP (e.g., 0.74 MBq) via the tail vein.
- Biodistribution:
 - At various time points post-injection (e.g., 30, 60, 120 minutes), euthanize the animals.
 - Collect blood and dissect major organs (heart, liver, lungs, kidneys, muscle, etc.).
 - Isolate the ischemic and non-ischemic regions of the heart.
- Quantification:
 - Weigh each organ and tissue sample.
 - Measure the radioactivity in each sample using a gamma counter.
 - Calculate the percentage of injected dose per gram of tissue (%ID/g).
- Data Analysis: Compare the %ID/g in different organs and between ischemic and non-ischemic heart tissue to assess the effect of ischemia on tracer uptake.

Data Presentation

Table 1: In Vitro Uptake of ^{123}I -BMIPP in Isolated Perfused Rat Hearts

This table summarizes the uptake of ^{123}I -BMIPP in isolated rat hearts perfused with different energy substrates. Data is adapted from a study investigating the metabolic fate of BMIPP.[5]

Energy Substrate	^{123}I -BMIPP Uptake (% Injected Dose/g)
0.4 mmol/L Oleate	28.0 ± 1.2
10 mmol/L Glucose + 25 U/L Insulin	43.9 ± 2.2
5 mmol/L Acetate	8.5 ± 0.4
0.4 mmol/L Cold BMIPP	6.2 ± 0.3

Table 2: Kinetic Parameters of ^{123}I -BMIPP in Isolated Rat Hearts under Ischemia-Reperfusion

This table presents the myocardial uptake (K1) and clearance (k2) rates of ^{123}I -BMIPP in an isolated rat heart model of no-flow ischemia followed by reperfusion.[7]

Group	Myocardial Uptake (K1, mL/min)	Myocardial Clearance (k2, min ⁻¹)
Normal Control (NG)	3.06 ± 0.88	0.0056 ± 0.0028
Mild Ischemia (MG)	3.91 ± 0.87	0.0029 ± 0.0010
Severe Ischemia (SG)	4.94 ± 1.51	0.0037 ± 0.0022

Experimental Workflow

The following diagram illustrates a general experimental workflow for studying fatty acid metabolism using iodinated tracers.

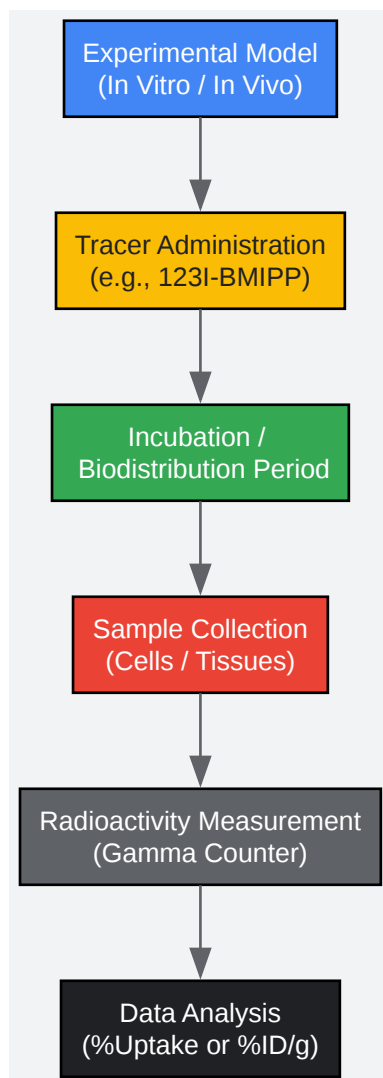

[Click to download full resolution via product page](#)

Caption: General experimental workflow.

Need Custom Synthesis?

BenchChem offers custom synthesis for rare earth carbides and specific isotopic labeling.

Email: info@benchchem.com or [Request Quote Online](#).

References

- 1. CD36, a signaling receptor and fatty acid transporter that regulates immune cell metabolism and fate - PMC [[pmc.ncbi.nlm.nih.gov](https://pubmed.ncbi.nlm.nih.gov/)]

- 2. CD36, a signaling receptor and fatty acid transporter that regulates immune cell metabolism and fate - PubMed [pubmed.ncbi.nlm.nih.gov]
- 3. 123I-BMIPP fatty acid analogue imaging is a novel diagnostic and prognostic approach following acute myocardial infarction - PubMed [pubmed.ncbi.nlm.nih.gov]
- 4. Cellular Fatty Acid Metabolism and Cancer - PMC [pmc.ncbi.nlm.nih.gov]
- 5. Metabolism of iodine-123-BMIPP in perfused rat hearts - PubMed [pubmed.ncbi.nlm.nih.gov]
- 6. kup.at [kup.at]
- 7. Accelerated BMIPP uptake immediately after reperfused ischemia in the isolated rat heart model - PubMed [pubmed.ncbi.nlm.nih.gov]
- To cite this document: BenchChem. [Application Notes and Protocols for Studying Fatty-Acid Metabolism with Iodinated Tracers]. BenchChem, [2025]. [Online PDF]. Available at: [https://www.benchchem.com/product/b15279452#experimental-design-for-fatty-acid-metabolism-with-iodinated-tracers]

Disclaimer & Data Validity:

The information provided in this document is for Research Use Only (RUO) and is strictly not intended for diagnostic or therapeutic procedures. While BenchChem strives to provide accurate protocols, we make no warranties, express or implied, regarding the fitness of this product for every specific experimental setup.

Technical Support: The protocols provided are for reference purposes. Unsure if this reagent suits your experiment? [[Contact our Ph.D. Support Team for a compatibility check](#)]

Need Industrial/Bulk Grade? [Request Custom Synthesis Quote](#)

BenchChem

Our mission is to be the trusted global source of essential and advanced chemicals, empowering scientists and researchers to drive progress in science and industry.

Contact

Address: 3281 E Guasti Rd

Ontario, CA 91761, United States

Phone: (601) 213-4426

Email: info@benchchem.com