

# Technical Support Center: Navigating the Stability of Pyrazole Carboxylic Acids in Solution

**Author:** BenchChem Technical Support Team. **Date:** May 2026

## Compound of Interest

Compound Name:	3-(3-Fluorophenyl)-1H-pyrazole-5-carboxylic acid
CAS No.:	1188375-17-8
Cat. No.:	B1527152

[Get Quote](#)

Welcome to the technical support center for researchers, scientists, and drug development professionals working with pyrazole carboxylic acids. This guide provides in-depth troubleshooting advice and frequently asked questions (FAQs) to address the stability challenges you may encounter during your experiments. Understanding the factors that influence the stability of these valuable compounds is critical for ensuring the accuracy, reproducibility, and success of your research.

## Introduction: The Duality of Reactivity and Stability

Pyrazole carboxylic acids are versatile building blocks in medicinal chemistry and materials science due to their unique structural and electronic properties.<sup>[1]</sup> However, the very features that make them reactive and useful also render them susceptible to degradation under certain experimental conditions. This guide is designed to provide you with the foundational knowledge and practical solutions to mitigate these stability issues, ensuring the integrity of your compounds and the reliability of your results.

## Frequently Asked Questions (FAQs)

Here we address some of the most common initial questions regarding the stability of pyrazole carboxylic acids in solution.

Q1: My pyrazole carboxylic acid solution is showing a decrease in concentration over time, even when stored in the dark. What could be the cause?

A: If photodegradation is ruled out, the most likely culprits are thermal degradation or pH-related instability. Pyrazole carboxylic acids can be susceptible to decarboxylation, especially at elevated temperatures.<sup>[1]</sup> Additionally, the pH of your solution can significantly impact stability. We recommend verifying the pH of your solution and ensuring your storage temperature is appropriate. See the troubleshooting section on Thermal Degradation for more details.

Q2: I've observed the formation of an unknown impurity in my sample during analysis by HPLC. How can I identify if it's a degradant?

A: Degradation can lead to the formation of various byproducts. A common degradation pathway is decarboxylation, which would result in a product with a lower molecular weight. Other possibilities include hydrolysis of ester or amide derivatives if you are working with a modified pyrazole carboxylic acid.<sup>[2]</sup> To identify the impurity, techniques such as LC-MS can be invaluable for determining the molecular weight of the unknown peak. A stability-indicating HPLC method is crucial for separating the parent compound from its potential degradants.<sup>[3][4]</sup>  
<sup>[5]</sup>

Q3: Are there any general guidelines for selecting a stable pH range for my pyrazole carboxylic acid solution?

A: The optimal pH for stability is highly dependent on the specific substituents on the pyrazole ring. As a general starting point, aim for a pH range where the carboxylic acid group is either fully protonated (acidic pH) or fully deprotonated (neutral to slightly alkaline pH). Extreme pH values (highly acidic or highly alkaline) should be approached with caution as they can catalyze hydrolysis or other degradation reactions, particularly for derivatives like esters or amides.<sup>[5]</sup> We recommend performing a pH stability profile study for your specific compound.

Q4: My experiment involves exposure to UV light. Are pyrazole carboxylic acids generally photostable?

A: The photochemical stability of pyrazole derivatives can vary. While some pyrazole-containing systems exhibit high photochemical stability, it should not be assumed for all such compounds.[6] Photodegradation is a potential issue, especially for compounds with extended conjugation or photosensitive substituents.[7] It is highly advisable to conduct forced degradation studies under UV light to assess the photostability of your specific pyrazole carboxylic acid.

## Troubleshooting Guides

This section provides more detailed insights into specific stability issues and offers practical solutions.

### Issue 1: Thermal Degradation and Decarboxylation

One of the most common stability issues for pyrazole carboxylic acids is thermal degradation, often proceeding through decarboxylation. This involves the loss of the carboxylic acid group as carbon dioxide.

**Causality:** The stability of the C-C bond between the pyrazole ring and the carboxylic acid group can be weakened by electronic effects of the pyrazole ring and its substituents. Elevated temperatures provide the activation energy needed to break this bond, leading to the formation of a pyrazole derivative without the carboxylic acid moiety.[1][8]

Troubleshooting Steps:

- **Temperature Control:**
  - **Storage:** Store stock solutions and samples at or below 4°C. For long-term storage, consider freezing at -20°C or -80°C, but be mindful of freeze-thaw cycles.
  - **Experimental Conditions:** If your experimental protocol involves heating, conduct a time-course study at the intended temperature to quantify the rate of degradation. If significant degradation occurs, explore alternative, lower-temperature methods if possible.
- **Solvent Selection:**

- While less common, the solvent can sometimes participate in degradation pathways. Ensure your chosen solvent is inert and of high purity.
- Structural Considerations:
  - Be aware that the position of the carboxylic acid group and the nature of other substituents on the pyrazole ring can influence the rate of decarboxylation.

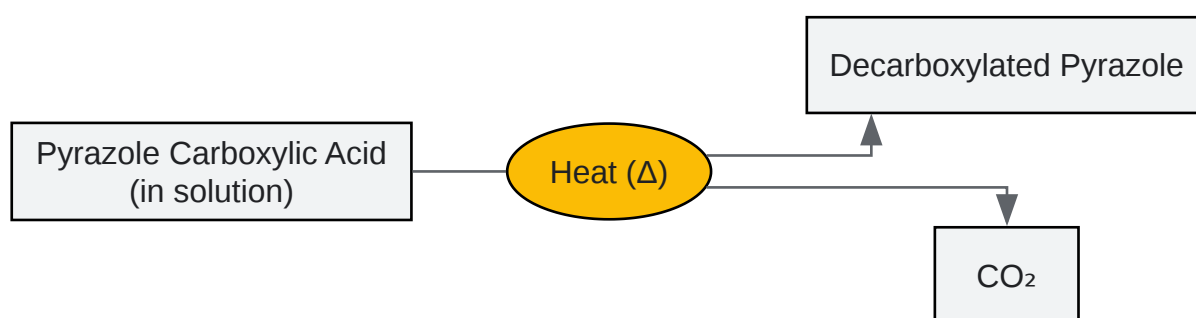

[Click to download full resolution via product page](#)

Caption: Thermal degradation of pyrazole carboxylic acids often proceeds via decarboxylation.

## Issue 2: pH-Dependent Instability and Hydrolysis

The pH of the solution is a critical factor governing the stability of pyrazole carboxylic acids and their derivatives.

Causality:

- Extreme pH: Both strongly acidic and strongly alkaline conditions can catalyze the degradation of the pyrazole ring itself or promote the hydrolysis of ester or amide derivatives of the carboxylic acid.[5]
- Ionization State: The ionization state of the carboxylic acid and the pyrazole ring nitrogens can influence the molecule's electronic distribution and, consequently, its susceptibility to degradation.

Troubleshooting Steps:

- pH Monitoring and Control:

- Always measure and record the pH of your solutions.
- Use appropriate buffer systems to maintain a stable pH throughout your experiment.
- pH Stability Profiling:
  - Conduct a forced degradation study across a range of pH values (e.g., pH 2, 4, 7, 9, 12) at a set temperature to identify the pH range of maximum stability for your specific compound.
- Prepare a stock solution of your pyrazole carboxylic acid in a suitable organic solvent (e.g., acetonitrile or methanol).
- Prepare a series of buffers covering the desired pH range.
- Spike the stock solution into each buffer to a final concentration suitable for your analytical method (e.g., HPLC-UV).
- Incubate the samples at a controlled temperature (e.g., 40°C or 50°C to accelerate degradation).
- At specified time points (e.g., 0, 2, 4, 8, 24 hours), withdraw an aliquot from each sample, quench any reaction if necessary (e.g., by neutralizing the pH), and analyze by a validated stability-indicating HPLC method.
- Plot the percentage of the parent compound remaining against time for each pH value to determine the degradation kinetics.

### Issue 3: Photodegradation

Exposure to light, particularly in the UV spectrum, can induce photochemical reactions leading to the degradation of pyrazole carboxylic acids.

Causality: The aromatic pyrazole ring can absorb UV radiation. This absorption of energy can excite the molecule to a higher energy state, where it can undergo various reactions such as ring cleavage, rearrangement, or reaction with other molecules in the solution.[7]

Troubleshooting Steps:

- Light Protection:
  - Work in a dimly lit environment or use amber glassware for preparing and storing solutions.
  - Protect samples from direct sunlight and fluorescent lighting.
- Forced Photostability Testing:
  - Expose a solution of your compound to a controlled light source (e.g., a photostability chamber with a combination of cool white fluorescent and near-UV lamps).
  - Analyze the sample at various time points to determine the rate of degradation. A dark control (sample protected from light but kept at the same temperature) should be run in parallel.

Time (hours)	% Parent Compound Remaining (Light Exposed)	% Parent Compound Remaining (Dark Control)
0	100	100
2	92	99.8
4	85	99.6
8	71	99.5
24	45	99.2

## Issue 4: Oxidative Degradation

The presence of oxidizing agents, including dissolved oxygen, can lead to the degradation of pyrazole carboxylic acids.

Causality: The electron-rich pyrazole ring can be susceptible to oxidation. This can lead to the formation of N-oxides or ring-opened products. The presence of certain metal ions can also catalyze oxidative degradation.<sup>[9][10]</sup>

#### Troubleshooting Steps:

- **Use of High-Purity Solvents:** Use freshly opened, high-purity solvents to minimize the presence of peroxide impurities.
- **Inert Atmosphere:** If your compound is particularly sensitive to oxidation, consider de-gassing your solvents and blanketing your solutions with an inert gas like nitrogen or argon.
- **Avoidance of Metal Contaminants:** Use high-quality reagents and glassware to avoid contamination with trace metals that can catalyze oxidation.
- **Addition of Antioxidants:** In some cases, the addition of a small amount of an antioxidant (e.g., BHT) may be considered, but its compatibility with your downstream application must be verified.

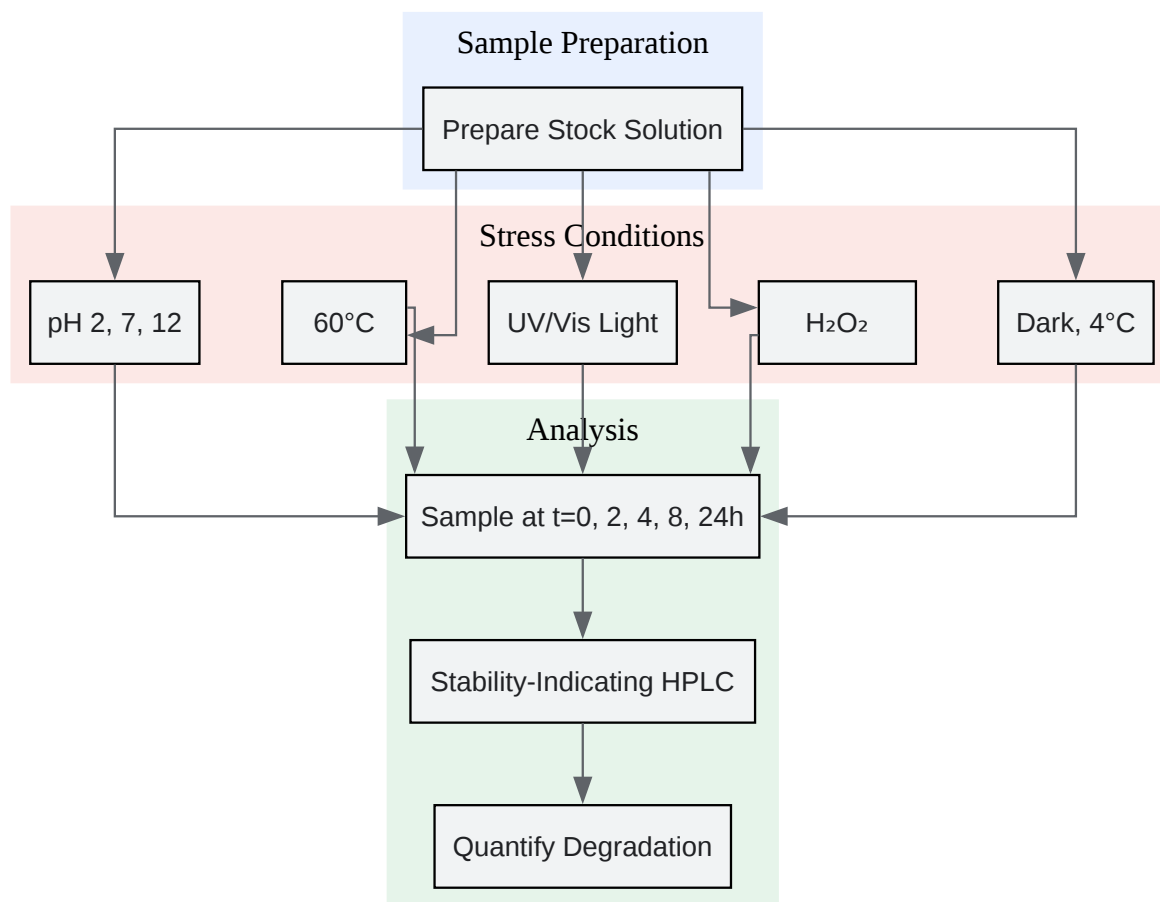

[Click to download full resolution via product page](#)

Caption: A typical workflow for assessing the stability of a pyrazole carboxylic acid.

## Concluding Remarks

The stability of pyrazole carboxylic acids in solution is a multifaceted issue that requires careful consideration of environmental factors such as temperature, pH, light, and the presence of oxidizing agents. By understanding the potential degradation pathways and implementing the troubleshooting strategies and experimental protocols outlined in this guide, you can significantly enhance the reliability and reproducibility of your work. Always remember that a proactive approach to stability assessment is a cornerstone of robust scientific research.

## References

- ResearchGate. (n.d.). Pyrazole-3-carboxylic acid as a new anchoring group for phthalocyanine-sensitized solar cells. Retrieved January 27, 2026, from [\[Link\]](#)
- ResearchGate. (n.d.). 1H-pyrazole-3-carboxylic acid: Experimental and computational study. Retrieved January 27, 2026, from [\[Link\]](#)
- National Institutes of Health. (n.d.). Approaches to the Synthesis of Dicarboxylic Derivatives of Bis(pyrazol-1-yl)alkanes. Retrieved January 27, 2026, from [\[Link\]](#)
- SAGE Journals. (n.d.). Synthesis, crystal structures and magnetic properties of Pyrazole-Carboxylic acid complexes. Retrieved January 27, 2026, from [\[Link\]](#)
- Wikipedia. (n.d.). Imidazole. Retrieved January 27, 2026, from [\[Link\]](#)
- ResearchGate. (n.d.). Pyrazole Carboxylic Acid and Derivatives: Synthesis and Biological Applications. Retrieved January 27, 2026, from [\[Link\]](#)
- Google Patents. (n.d.). Method for preparing pyrazolecarboxylic acid and derivatives.
- SIELC Technologies. (n.d.). Separation of 1H-Pyrazole-3-carboxylic acid, 4,5-dihydro-1-(2-methyl-4-sulphophenyl)-5-oxo- on Newcrom R1 HPLC column. Retrieved January 27, 2026, from [\[Link\]](#)
- ResearchGate. (n.d.). Pyrolysis of Carboxylic Acids. Retrieved January 27, 2026, from [\[Link\]](#)
- AIP Publishing. (n.d.). Comparative Investigation of Reactivity, Stability, Structural and Thermodynamic Parameters of Heterocyclic Carboxylic Acids and Their Benzofused Derivatives. Retrieved January 27, 2026, from [\[Link\]](#)
- ResearchGate. (n.d.). Unsymmetrically pyrazole-3-carboxylic acid substituted phthalocyanine-based photoanodes for use in water splitting photoelectrochemical and dye-sensitized solar cells. Retrieved January 27, 2026, from [\[Link\]](#)
- International Journal of Chemico-Pharmaceutical Analysis. (n.d.). A Highly Validated RP-HPLC Method for Pyrazoline Derivative Having Anti-inflammatory Activity. Retrieved January 27, 2026, from [\[Link\]](#)

- National Institutes of Health. (n.d.). N-Heterocyclic Carbene/Carboxylic Acid Co-Catalysis Enables Oxidative Esterification of Demanding Aldehydes/Enals, at Low Catalyst Loading. Retrieved January 27, 2026, from [\[Link\]](#)
- ACS Publications. (n.d.). Azo Pyrazole Carboxylic Derivatives for Potential Energetic Materials. Retrieved January 27, 2026, from [\[Link\]](#)
- Royal Society of Chemistry. (n.d.). Supporting Information. Retrieved January 27, 2026, from [\[Link\]](#)
- Elsevier. (n.d.). A stable N-containing heterocyclic carboxylic acid ligand Co-MOF for photoelectric performance and anionic dyes adsorption. Retrieved January 27, 2026, from [\[Link\]](#)
- ResearchGate. (n.d.). Oxidations by a H<sub>2</sub>O<sub>2</sub>-VO<sub>3</sub> --pyrazine-2-carboxylic acid reagent. Retrieved January 27, 2026, from [\[Link\]](#)
- Pharmacia. (2019). Development and validation of RP-HPLC method for stability evaluation of model hydrazone, containing a pyrrole ring. Retrieved January 27, 2026, from [\[Link\]](#)
- Asian Journal of Chemistry. (n.d.). Reactions of Some Pyrazole-3-Carboxylic Acid Chlorides with Various Anilides. Retrieved January 27, 2026, from [\[Link\]](#)
- PubMed. (2014). Synthesis, structure-activity relationships, and in vitro antibacterial and antifungal activity evaluations of novel pyrazole carboxylic and dicarboxylic acid derivatives. Retrieved January 27, 2026, from [\[Link\]](#)
- MDPI. (2022). M-Carboxylic Acid Induced Formation of New Coordination Polymers for Efficient Photocatalytic Degradation of Ciprofloxacin. Retrieved January 27, 2026, from [\[Link\]](#)
- PubMed. (2022). Synthesis, characterization and thermal degradation kinetics of a new pyrazole derived methacrylate polymer, poly(1,3-diphenyl-1H-pyrazol-5-yl methacrylate). Retrieved January 27, 2026, from [\[Link\]](#)
- Domainex. (2023). Synthesis in Review: Unusual reactivity of carboxylic acids using nickel or N-heterocyclic carbene (NHC) catalysis. Retrieved January 27, 2026, from [\[Link\]](#)

- PubMed. (n.d.). Synthesis of some substituted pyrazole-3-carboxylic acids with possible hypoglycemic and antimicrobial activity. Retrieved January 27, 2026, from [[Link](#)]
- PubMed. (2022). Photocatalytic Direct Decarboxylation of Carboxylic Acids to Derivatize or Degrade Polymers. Retrieved January 27, 2026, from [[Link](#)]
- Royal Society of Chemistry. (n.d.). Influence of the terminal group on the thermal decomposition reactions of carboxylic acids on copper: nature of the carbonaceous film. Retrieved January 27, 2026, from [[Link](#)]
- MDPI. (n.d.). Direct Catalytic Amidations from Carboxylic Acid and Ester Derivatives: A Review. Retrieved January 27, 2026, from [[Link](#)]
- Journal of the American Chemical Society. (n.d.). A Robust Pyrazolate Metal–Organic Framework for Efficient Catalysis of Dehydrogenative C–O Cross Coupling Reaction. Retrieved January 27, 2026, from [[Link](#)]
- Quick Company. (n.d.). Process For The Manufacture Of Pyrazole Carboxylic Derivatives And Precursors Thereof. Retrieved January 27, 2026, from [[Link](#)]
- ResearchGate. (n.d.). Oxidation with the “O<sub>2</sub>–H<sub>2</sub>O<sub>2</sub>–VO<sub>3</sub>–pyrazine-2-carboxylic acid” reagent. Retrieved January 27, 2026, from [[Link](#)]

### Need Custom Synthesis?

BenchChem offers custom synthesis for rare earth carbides and specific isotopic labeling.

Email: [info@benchchem.com](mailto:info@benchchem.com) or [Request Quote Online](#).

## Sources

- 1. [researchgate.net](https://www.researchgate.net) [[researchgate.net](https://www.researchgate.net)]
- 2. [Process For The Manufacture Of Pyrazole Carboxylic Derivatives And](#) [[quickcompany.in](https://www.quickcompany.in)]
- 3. [Separation of 1H-Pyrazole-3-carboxylic acid, 4,5-dihydro-1-\(2-methyl-4-sulfophenyl\)-5-oxo- on Newcrom R1 HPLC column | SIELC Technologies](#) [[sielc.com](https://www.sielc.com)]
- 4. [ijcpa.in](https://www.ijcpa.in) [[ijcpa.in](https://www.ijcpa.in)]

- [5. Development and validation of RP-HPLC method for stability evaluation of model hydrazone, containing a pyrrole ring \[pharmacia.pensoft.net\]](#)
- [6. researchgate.net \[researchgate.net\]](#)
- [7. mdpi.com \[mdpi.com\]](#)
- [8. Influence of the terminal group on the thermal decomposition reactions of carboxylic acids on copper: nature of the carbonaceous film - Physical Chemistry Chemical Physics \(RSC Publishing\) \[pubs.rsc.org\]](#)
- [9. researchgate.net \[researchgate.net\]](#)
- [10. researchgate.net \[researchgate.net\]](#)
- To cite this document: BenchChem. [Technical Support Center: Navigating the Stability of Pyrazole Carboxylic Acids in Solution]. BenchChem, [2026]. [Online PDF]. Available at: [\[https://www.benchchem.com/product/b1527152/docs#technical-support-center-navigating-the-stability-of-pyrazole-carboxylic-acids-in-solution\]](https://www.benchchem.com/product/b1527152/docs#technical-support-center-navigating-the-stability-of-pyrazole-carboxylic-acids-in-solution)

---

### Disclaimer & Data Validity:

The information provided in this document is for Research Use Only (RUO) and is strictly not intended for diagnostic or therapeutic procedures. While BenchChem strives to provide accurate protocols, we make no warranties, express or implied, regarding the fitness of this product for every specific experimental setup.

**Technical Support:** The protocols provided are for reference purposes. Unsure if this reagent suits your experiment?

**Need Industrial/Bulk Grade?** [Request Custom Synthesis Quote](#)

## BenchChem

Our mission is to be the trusted global source of essential and advanced chemicals, empowering scientists and researchers to drive progress in science and industry.

### Contact

Address: 3281 E Guasti Rd  
Ontario, CA 91761, United States  
Phone: (601) 213-4426  
Email: [info@benchchem.com](mailto:info@benchchem.com)

Contact our Ph.D. Support Team for a compatibility check