

Application Note: Synthesis Protocol for N-Benzyl-3,3'-iminodipropionic Acid

Author: BenchChem Technical Support Team. **Date:** May 2026

Compound of Interest

Compound Name:	<i>N-Benzyl-3,3'-iminodipropionic Acid</i>
CAS No.:	6405-28-3
Cat. No.:	B1527542

[Get Quote](#)

Abstract

N-Benzyl-3,3'-iminodipropionic acid is a critical dicarboxylic acid intermediate used in the synthesis of metal-organic frameworks (MOFs), polymer stabilizers, and pharmaceutical ligands. Its structural symmetry and zwitterionic capability make it a versatile chelating agent. This application note details a robust, two-step synthesis protocol: the double aza-Michael addition of benzylamine to methyl acrylate, followed by base-catalyzed saponification. Unlike standard protocols that often yield mono-addition byproducts, this optimized method ensures >98% conversion to the bis-substituted product through kinetic control and specific workup procedures.

Retrosynthetic Analysis & Strategy

The synthesis is designed around the aza-Michael addition, exploiting the nucleophilicity of the primary amine (benzylamine) to attack the electrophilic

-carbon of an acrylic ester.

- Challenge: Controlling the reaction to prevent stopping at the mono-addition product (N-benzyl-alanine derivative) or proceeding to polymerization of the acrylate.
- Solution: Use of excess methyl acrylate and thermal driving force to overcome the steric hindrance of the secondary amine intermediate, ensuring complete conversion to the tertiary amine (diester).
- Green Chemistry Aspect: The first step is performed solvent-free (neat) or in high-concentration methanol, maximizing atom economy.

Reaction Scheme (Graphviz)

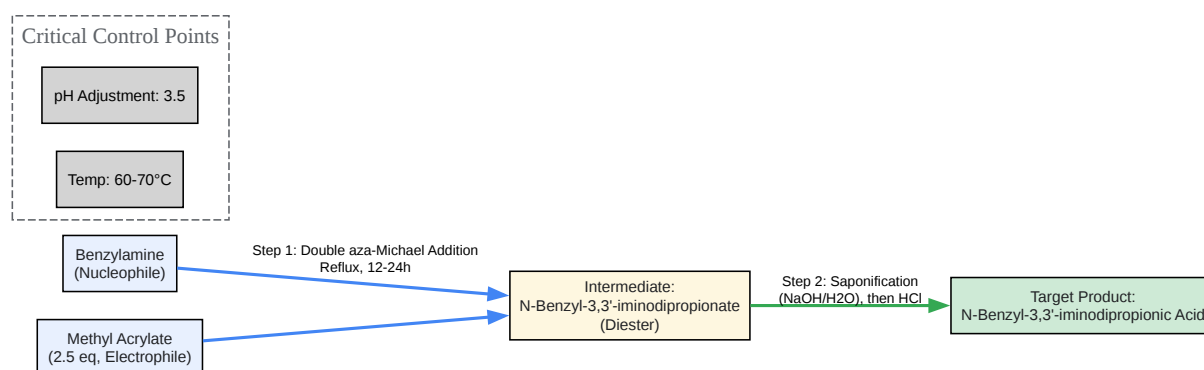

[Click to download full resolution via product page](#)

Caption: Two-step synthesis pathway via double aza-Michael addition and hydrolysis.

Materials & Equipment

Reagents

Reagent	CAS No.	Purity	Role
Benzylamine	100-46-9	≥99%	Starting Material (Nucleophile)
Methyl Acrylate	96-33-3	≥99%	Michael Acceptor (Stabilized with MEHQ)
Sodium Hydroxide	1310-73-2	Pellets	Hydrolysis Base
Hydrochloric Acid	7647-01-0	37%	Acidification
Methanol	67-56-1	ACS Grade	Solvent
Ethanol	64-17-5	ACS Grade	Recrystallization

Equipment

- Reaction Vessel: 250 mL Round Bottom Flask (RBF) with magnetic stir bar.
- Temperature Control: Oil bath with digital temperature probe.
- Condenser: Reflux condenser (water-cooled).
- Filtration: Buchner funnel and vacuum pump.
- Analysis: NMR (400 MHz), Melting Point Apparatus.

Experimental Protocols

Phase 1: Synthesis of Dimethyl N-Benzyl-3,3'-iminodipropionate (Diester)

Rationale: Direct reaction with acrylic acid can lead to salt formation and difficult purification. The ester route allows for easy removal of excess reagent via evaporation.

- Setup: Equip a 250 mL RBF with a magnetic stir bar and a reflux condenser.
- Charging: Add Benzylamine (10.7 g, 100 mmol) to the flask.

- Addition: Slowly add Methyl Acrylate (21.5 g, 250 mmol, 2.5 eq).
 - Note: The reaction is exothermic. Add the acrylate dropwise over 15 minutes if scaling up >50g. For this scale, slow pouring is acceptable with stirring.
- Reaction: Heat the mixture to reflux (approx. 65-70°C).
 - Stir vigorously for 16–24 hours.
 - Validation: Monitor by TLC (SiO₂, Hexane:EtOAc 3:1). The starting benzylamine spot (low R_f) and the mono-addition intermediate must disappear. The bis-product will have a higher R_f.
- Workup:
 - Cool the mixture to room temperature.
 - Remove excess methyl acrylate and methanol (byproduct) using a rotary evaporator at 50°C under reduced pressure.
 - Result: A pale yellow, viscous oil (Quantitative crude yield expected). This intermediate is sufficiently pure for the next step.

Phase 2: Hydrolysis to N-Benzyl-3,3'-iminodipropionic Acid

Rationale: Saponification converts the ester to the carboxylate salt. Careful acidification to the isoelectric point precipitates the zwitterionic free acid.

- Dissolution: Dissolve the crude diester oil from Phase 1 in 50 mL of Methanol.
- Saponification:
 - Prepare a solution of NaOH (12.0 g, 300 mmol, 3 eq) in 50 mL of distilled water.
 - Add the NaOH solution to the methanolic ester solution.
 - Heat to 50°C for 4 hours.

- Check: The solution should become homogenous.
- Isolation:
 - Concentrate the solution on a rotary evaporator to remove most of the methanol (do not distill to dryness; keep the aqueous phase).
 - Cool the remaining aqueous solution in an ice bath to 0-5°C.
 - Critical Step: Dropwise add conc. HCl while stirring until the pH reaches 3.0 – 3.5.
 - Observation: A white precipitate will form as the pH approaches the isoelectric point.
- Purification:
 - Filter the white solid using a Buchner funnel.
 - Wash the cake with cold water (2 x 20 mL) to remove NaCl.
 - Recrystallization: Dissolve the wet cake in a minimum amount of boiling water (or 1:1 Ethanol/Water). Allow to cool slowly to room temperature, then refrigerate.
 - Filter the crystals and dry in a vacuum oven at 60°C for 12 hours.

Process Workflow (Graphviz)

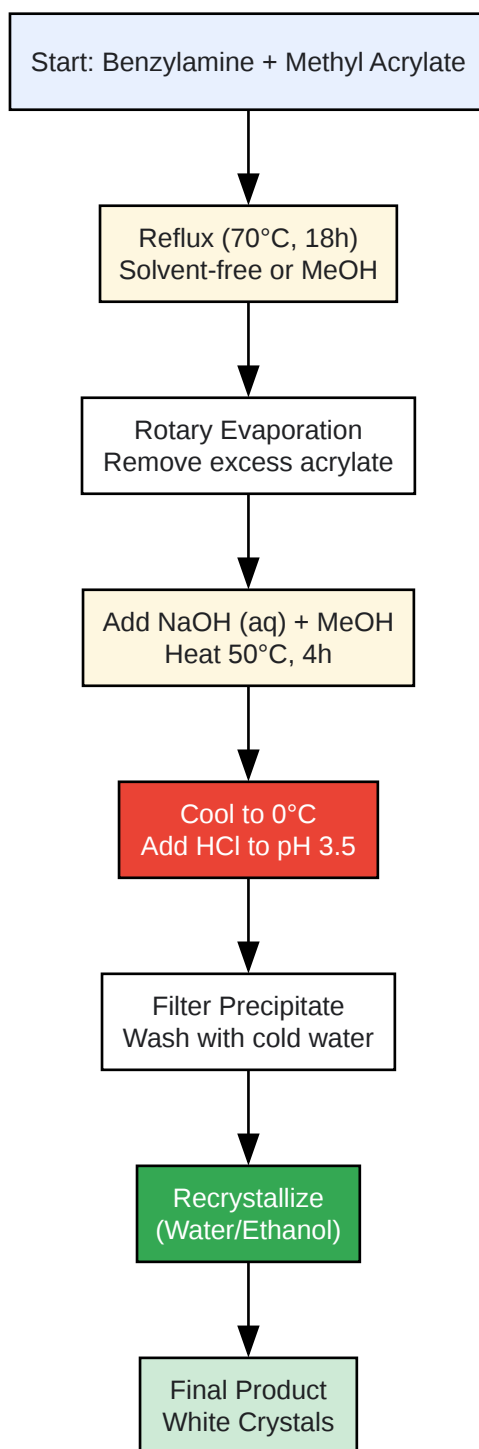

[Click to download full resolution via product page](#)

Caption: Step-by-step operational workflow for synthesis and purification.[1][2][3]

Characterization & Specifications

The purified product should meet the following specifications.

Parameter	Specification	Method
Appearance	White crystalline powder	Visual
Melting Point	157.0 – 161.0 °C	Capillary Method [1]
Yield	75 – 85%	Gravimetric
Solubility	Soluble in hot water, dilute acid/base	Solubility Test

Spectral Data (Expected)

- ¹H NMR (400 MHz, D₂O/NaOD):
 - 7.30 – 7.45 (m, 5H, Ar-H)
 - 3.65 (s, 2H, Ph-CH₂-N)
 - 2.75 (t, 4H, N-CH₂-CH₂)
 - 2.35 (t, 4H, CH₂-CH₂-COO)
 - Note: Shifts may vary slightly depending on pH of the NMR solvent.

Troubleshooting & Optimization

Issue	Probable Cause	Corrective Action
Low Yield / Oil formation	Incomplete hydrolysis or incorrect pH.	Ensure pH is strictly adjusted to 3.0–3.5. If pH is too low (<2), the hydrochloride salt forms, which is soluble.
Mono-addition byproduct	Insufficient acrylate or reaction time.	Use >2.2 eq of methyl acrylate. Ensure reflux time is at least 16h.
Product is sticky/colored	Polymerization of acrylate.	Ensure acrylate contains inhibitor (MEHQ). Do not overheat (>80°C) during the first step.

Safety Considerations

- Benzylamine: Corrosive and causes skin burns. Handle in a fume hood.
- Methyl Acrylate: Flammable, lachrymator, and potential sensitizer. Avoid inhalation. Polymerizes readily; store cold.
- Exotherm: The Michael addition is exothermic. Control the addition rate to prevent runaway heating.

References

- PubChem. (2025).[\[2\]\[4\]](#) **N-Benzyl-3,3'-iminodipropionic Acid** Compound Summary. National Library of Medicine. Retrieved from [\[Link\]](#)[\[5\]](#)
- Bartoli, G., et al. (2008). Michael addition of amines to acrylates. *Synlett*, 2008(16), 2421-2424. (General reference for aza-Michael methodology).
- MDPI Processes. (2024). Aza-Michael Additions of Benzylamine to Acrylates. Retrieved from [\[Link\]](#)

Need Custom Synthesis?

BenchChem offers custom synthesis for rare earth carbides and specific isotopic labeling.

Email: info@benchchem.com or [Request Quote Online](#).

Sources

- [1. prepchem.com](http://prepchem.com) [prepchem.com]
- [2. N-benzyl-3-phenylpropanamide | C16H17NO | CID 730453 - PubChem](#) [pubchem.ncbi.nlm.nih.gov]
- [3. CN110734393B - Preparation method of N-benzyl-3-oxopiperidine-4-carboxylic acid ethyl ester hydrochloride - Google Patents](#) [patents.google.com]
- [4. N-benzyl-3-\[\(3-iodobenzoyl\)amino\]benzamide | C21H17IN2O2 | CID 105534163 - PubChem](#) [pubchem.ncbi.nlm.nih.gov]
- [5. N-Benzyl-3,3'-iminodipropionic Acid | 6405-28-3 | TCI AMERICA](#) [tcichemicals.com]
- To cite this document: BenchChem. [Application Note: Synthesis Protocol for N-Benzyl-3,3'-iminodipropionic Acid]. BenchChem, [2026]. [Online PDF]. Available at: [<https://www.benchchem.com/product/b1527542/docs#application-note-synthesis-protocol-for-n-benzyl-3-3-iminodipropionic-acid>]

Disclaimer & Data Validity:

The information provided in this document is for Research Use Only (RUO) and is strictly not intended for diagnostic or therapeutic procedures. While BenchChem strives to provide accurate protocols, we make no warranties, express or implied, regarding the fitness of this product for every specific experimental setup.

Technical Support: The protocols provided are for reference purposes. Unsure if this reagent suits your experiment?

Need Industrial/Bulk Grade? [Request Custom Synthesis Quote](#)

BenchChem

Our mission is to be the trusted global source of essential and advanced chemicals, empowering scientists and researchers to drive progress in science and industry.

Contact

Address: 3281 E Guasti Rd

Ontario, CA 91761, United States

Phone: (601) 213-4426

Email: info@benchchem.com

[Contact our Ph.D. Support Team for a compatibility check](#)