

Application Note: Synthesis and Purification of Benzyl Orange Indicator

Author: BenchChem Technical Support Team. **Date:** May 2026

Compound of Interest

Compound Name: *Benzyl orange*

CAS No.: *36402-77-4*

Cat. No.: *B1526881*

[Get Quote](#)

Abstract

This application note details the optimized protocol for the synthesis of **Benzyl Orange** (Sodium 4-(benzylamino)azobenzene-4'-sulfonate), an acid-base indicator with a transition range of pH 1.9 (Red) to 3.3 (Yellow).[1] Unlike the ubiquitous Methyl Orange, **Benzyl Orange** utilizes an N-benzyl moiety, altering its pKa and lipophilicity.[1] The synthesis proceeds via the diazotization of sulfanilic acid followed by electrophilic aromatic substitution (coupling) with N-benzylaniline. This guide emphasizes critical process parameters (CPPs) such as temperature control (

C), pH regulation during coupling, and purification strategies to minimize triazene by-products.

Scientific Principles & Reaction Mechanism[2]

The Diazotization-Coupling Pathway

The synthesis is a classic two-step azo coupling sequence. The high scientific integrity of this protocol relies on understanding the reactivity of the diazonium intermediate and the regioselectivity of the coupling step.

- Diazotization: Sulfanilic acid exists as a zwitterion.[1] In the presence of sodium nitrite and hydrochloric acid, the amine group is converted into a diazonium ion.[2] Because of the sulfonate group, the product is an internal salt (diazonium betaine), which is insoluble in cold water and precipitates.
 - Mechanism:[1][3][4]

[1]

- Coupling: The diazonium electrophile attacks the electron-rich aromatic ring of N-benzylaniline.[1]
 - Regioselectivity:[1] The bulky benzyl group and the amino nitrogen direct the attack to the para position relative to the amine. Steric hindrance usually prevents ortho coupling.[1]
 - pH Control: Coupling is optimal in weakly acidic media (pH ~4-5).[1] If too acidic, the amine coupler becomes protonated (ammonium) and deactivated.[1] If too alkaline, the diazonium salt reacts with hydroxide to form diazotates, which do not couple.[1]

Reaction Scheme Visualization

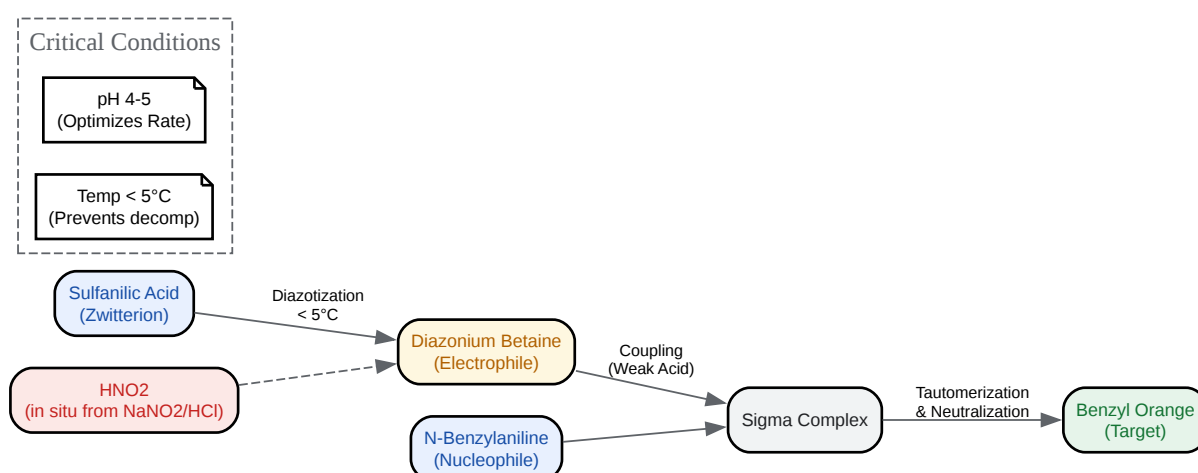

[Click to download full resolution via product page](#)

Figure 1: Mechanistic pathway for the synthesis of **Benzyl Orange**, highlighting the formation of the diazonium betaine and subsequent coupling.[1]

Experimental Protocol

Reagents and Equipment

Reagent	CAS No.[1][5]	Grade	Function
Sulfanilic Acid (Anhydrous)	121-57-3	ACS Reagent	Diazonium precursor
Sodium Nitrite ()	7632-00-0	ACS Reagent	Nitrosating agent
N-Benzylaniline	103-32-2	>98%	Coupling component
Hydrochloric Acid (conc.)	7647-01-0	37%	Acid catalyst
Sodium Hydroxide	1310-73-2	10% w/v Soln	Neutralization
Glacial Acetic Acid	64-19-7	ACS Reagent	Solvent for coupler

Equipment:

- 500 mL 3-neck Round Bottom Flask (RBF)[1][6]
- Mechanical Stirrer (preferred over magnetic for slurry handling)[1]
- Ice/Salt Bath[1][7]
- Addition Funnel (pressure-equalizing)[1]
- Vacuum Filtration Setup (Büchner funnel)[1][6]

Step-by-Step Methodology

Phase 1: Diazotization of Sulfanilic Acid[2][8]

- **Dissolution:** In the 500 mL RBF, dissolve 2.5 g of Sodium Carbonate in 100 mL of water. Add 4.8 g (25 mmol) of Sulfanilic Acid. Warm gently until a clear solution is obtained (formation of sodium sulfanilate).
- **Nitrite Addition:** Cool the solution to 15°C. Add 1.9 g (27 mmol) of Sodium Nitrite dissolved in 10 mL of water.
- **Precipitation:** Prepare a beaker containing 25 g of crushed ice and 5 mL of concentrated HCl. Pour the sulfanilate/nitrite solution slowly into the acid-ice mixture with vigorous stirring.
 - **Observation:** A fine, white powdery precipitate of the diazonium betaine will form immediately.[\[1\]](#)
 - **Critical Check:** Test the supernatant with starch-iodide paper.[\[1\]](#) An immediate blue color indicates the required excess of nitrous acid.
 - **Hold:** Keep this suspension below 5°C. Do not filter; the slurry is used directly.

Phase 2: Preparation of Coupling Component[\[1\]](#)

- In a separate flask, dissolve 4.6 g (25 mmol) of N-Benzylaniline in 20 mL of Glacial Acetic Acid.
 - **Note:** N-Benzylaniline is hydrophobic.[\[1\]](#) Acetic acid ensures solubility and buffers the reaction pH.

Phase 3: Coupling Reaction[\[1\]](#)

- **Addition:** Slowly add the N-benzylaniline solution to the stirred diazonium suspension. Maintain temperature C.
- **Reaction Time:** Stir the dark red mixture for 15 minutes.
- **pH Adjustment:** The coupling is slow in strong acid. Slowly add 10% NaOH solution dropwise until the mixture becomes essentially neutral or weakly acidic (pH ~5-6).
 - **Observation:** The reaction mixture will thicken and darken as the coupling proceeds.

- Caution: Do not make the solution strongly alkaline yet, as this may form gums.[1]
- Completion: Allow the mixture to stir at room temperature for 30 minutes.

Phase 4: Isolation and Conversion to Sodium Salt

- Alkalinization: Add 10% NaOH until the solution is clearly alkaline (pH > 10).[1]
 - Color Change: The suspension will shift from the acidic red/purple form to the basic orange/yellow salt form.
- Crystallization: Heat the mixture to boiling (approx. 100°C) to dissolve the solid. Add 10 g of Sodium Chloride (salting out) to lower the solubility of the product.
- Cooling: Allow the beaker to cool slowly to room temperature, then place in an ice bath. Shiny orange-yellow leaflets/scales of **Benzyl Orange** should crystallize.[1]
- Filtration: Filter the product using vacuum filtration. Wash with a small amount of cold saturated NaCl solution, followed by a minimal amount of cold ethanol (to remove unreacted amine).[1]
- Drying: Dry the product in a desiccator or oven at 60°C.

Analytical Characterization

Expected Properties[1][9]

- Appearance: Orange-yellow crystalline powder.[1][5]
- Solubility: Soluble in hot water; moderately soluble in ethanol; insoluble in ether.[1]
- pH Transition:
 - pH < 1.9: Red (Quinonoid form)[1]
 - pH > 3.3: Yellow (Azobenzene form)[1]

Quality Control (QC) Table

Test	Method	Acceptance Criteria
Identity	IR Spectroscopy	Peaks at 1600 (N=N), 1030 (Sulfonate)
Lambda Max	UV-Vis (in water)	~460 nm (Basic form), ~505 nm (Acidic form)
Melting Point	Capillary Method	Decomposes > 280°C (typical for sulfonates)
Sensitivity	Titration	Sharp color change with 0.1N HCl

Troubleshooting & Critical Process Parameters

Common Failure Modes

- Oiling Out: If the product separates as a dark oil/tar rather than crystals, the reaction temperature was likely too high during coupling, or the pH was raised too quickly.
 - Remedy: Re-acidify slightly with acetic acid, heat to dissolve, and cool very slowly with vigorous stirring.
- Low Yield: Often due to decomposition of the diazonium salt before coupling.^[1]
 - Prevention:^[1] Ensure the diazonium slurry never exceeds 5°C.
- Impurity (Triazines): Coupling at the nitrogen atom (N-coupling) instead of the ring (C-coupling) can occur.^[1]
 - Prevention:^[1] Ensure the coupling environment is not too acidic (which favors C-coupling) but allow sufficient time before basifying.^[1]

Workflow Diagram

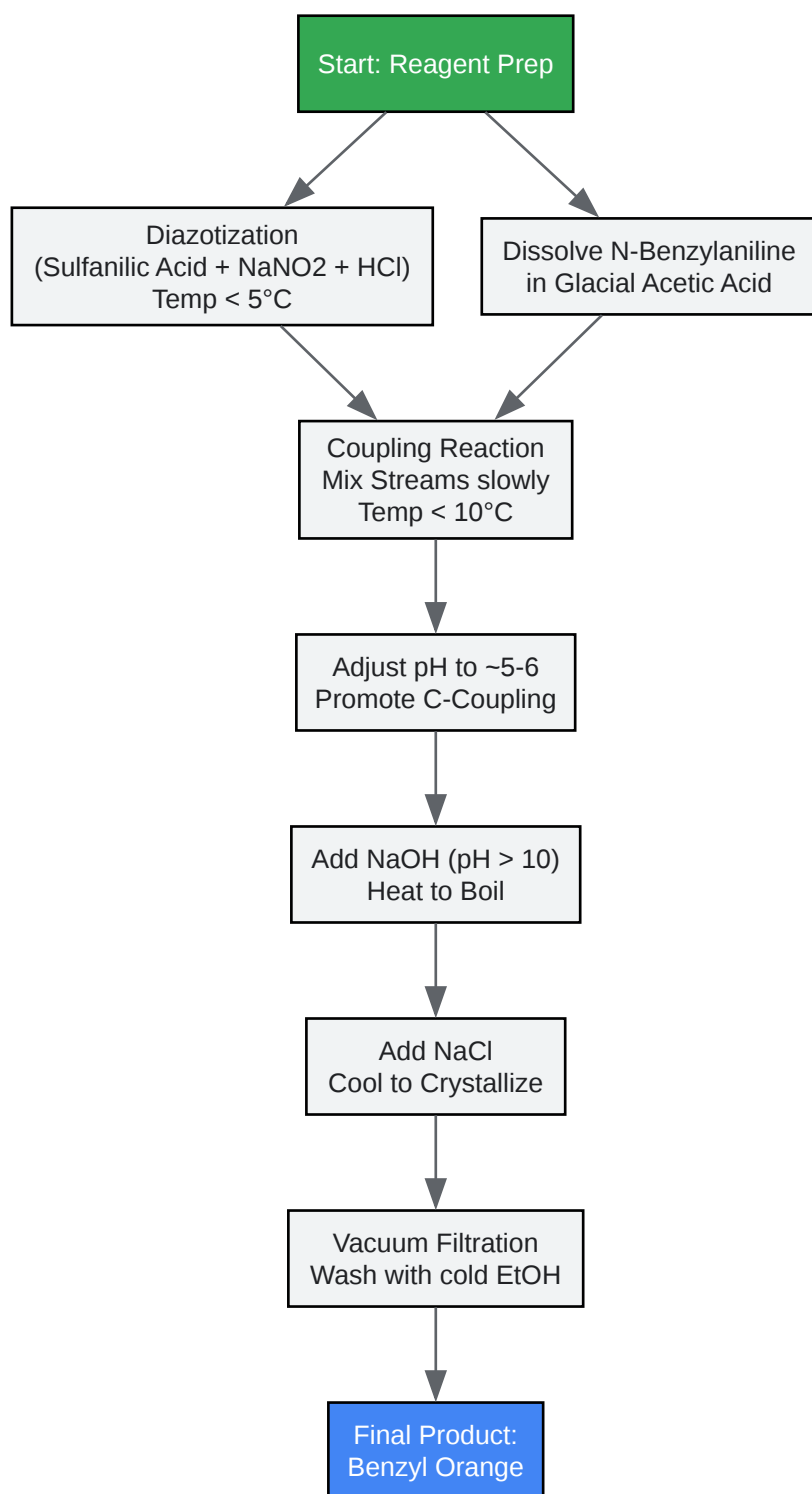

[Click to download full resolution via product page](#)

Figure 2: Operational workflow for the batch synthesis of **Benzyl Orange**.^[1]

References

- Vogel, A. I. (1989).[1] Vogel's Textbook of Practical Organic Chemistry (5th ed.).[1] Longman Scientific & Technical.[1][9] (Standard reference for diazonium coupling protocols).
- Scribd. (n.d.).[1] Lab 13 A Diazotization-Coupling Reaction - The Preparation of Methyl Orange. Retrieved February 6, 2026, from [[Link](#)]
- MacsChem. (n.d.).[1] Methyl Orange Properties and Synthesis. Retrieved February 6, 2026, from [[Link](#)][1]
- Royal Society of Chemistry. (n.d.).[1] Synthesis of Methyl Orange. Retrieved February 6, 2026, from [[Link](#)]

Need Custom Synthesis?

BenchChem offers custom synthesis for rare earth carbides and specific isotopic labeling.

Email: info@benchchem.com or [Request Quote Online](#).

Sources

- 1. Methyl orange - Wikipedia [en.wikipedia.org]
- 2. scribd.com [scribd.com]
- 3. byjus.com [byjus.com]
- 4. scribd.com [scribd.com]
- 5. macschem.us [macschem.us]
- 6. Organic Syntheses Procedure [orgsyn.org]
- 7. gcwgandhinagar.com [gcwgandhinagar.com]
- 8. scribd.com [scribd.com]
- 9. scribd.com [scribd.com]
- To cite this document: BenchChem. [Application Note: Synthesis and Purification of Benzyl Orange Indicator]. BenchChem, [2026]. [Online PDF]. Available at: [<https://www.benchchem.com/product/b1526881/docs#application-note-synthesis-and-purification-of-benzyl-orange-indicator>]

Disclaimer & Data Validity:

The information provided in this document is for Research Use Only (RUO) and is strictly not intended for diagnostic or therapeutic procedures. While BenchChem strives to provide accurate protocols, we make no warranties, express or implied, regarding the fitness of this product for every specific experimental setup.

Technical Support: The protocols provided are for reference purposes. Unsure if this reagent suits your experiment?

Need Industrial/Bulk Grade? [Request Custom Synthesis Quote](#)

BenchChem

Our mission is to be the trusted global source of essential and advanced chemicals, empowering scientists and researchers to drive progress in science and industry.

Contact

Address: 3281 E Guasti Rd
Ontario, CA 91761, United States
Phone: (601) 213-4426
Email: info@benchchem.com

[Contact our Ph.D. Support Team for a compatibility check](#)