

1-BOC-5-Trifluoromethoxy Indole: Synthesis & Process Guide

Author: BenchChem Technical Support Team. **Date:** May 2026

Compound of Interest

Compound Name: 1-BOC-5-trifluoromethoxy indole

CAS No.: 1325730-40-2

Cat. No.: B1526916

[Get Quote](#)

Executive Summary & Strategic Analysis

Target Molecule: 1-(tert-Butoxycarbonyl)-5-(trifluoromethoxy)-1H-indole Core Application: Medicinal chemistry intermediate for modulating lipophilicity and metabolic stability. CAS Registry Number (Parent Indole): 262593-63-5 (5-Trifluoromethoxyindole)[1]

The synthesis of **1-BOC-5-trifluoromethoxy indole** presents a specific challenge in heterocyclic chemistry: balancing the electronic deactivation of the indole ring (induced by the electron-withdrawing -OCF

group) with the steric and electronic requirements of the tert-butyloxycarbonyl (BOC) protection step.

The trifluoromethoxy group (

) increases the acidity of the N-H bond (

~15.5 vs. 17 for unsubstituted indole), theoretically facilitating deprotonation. However, it simultaneously reduces the nucleophilicity of the resulting indolyl anion, necessitating the use of hyper-nucleophilic catalysts like DMAP to drive the reaction to completion efficiently.

This guide outlines two distinct pathways:

- Pathway A (Direct Protection): The standard high-throughput route using commercial 5-trifluoromethoxy indole.
- Pathway B (De Novo Synthesis): A robust Fischer Indole protocol for generating the core scaffold from 4-(trifluoromethoxy)phenylhydrazine, essential when commercial stock is unavailable or cost-prohibitive.

Retrosynthetic Analysis

The strategic disconnection reveals the indole core as the primary sub-target, which can be further disconnected via the Fischer Indole Synthesis.

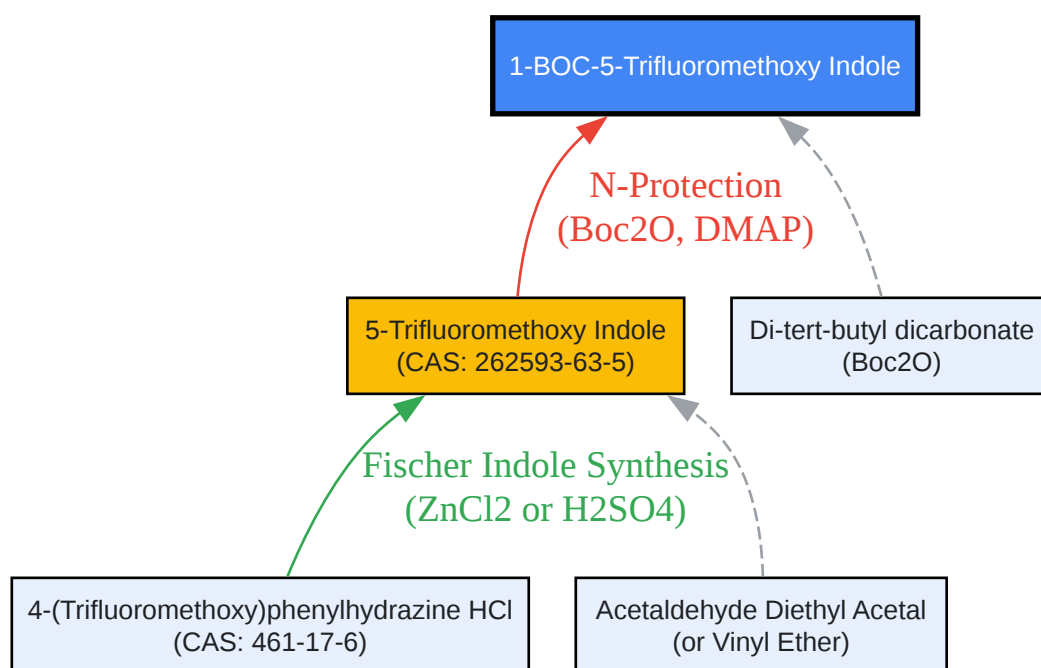

[Click to download full resolution via product page](#)

Figure 1: Retrosynthetic disconnection showing the convergent assembly of the target.

Pathway A: Direct N-BOC Protection (Standard Route)

Context: This is the preferred route for medicinal chemistry campaigns where speed is critical. The reaction utilizes 4-dimethylaminopyridine (DMAP) as a nucleophilic catalyst to overcome the reduced nucleophilicity of the 5-OCF

indole.

Reaction Scheme

Experimental Protocol

Scale: 10.0 mmol basis Reagents:

- 5-(Trifluoromethoxy)indole (2.01 g, 10.0 mmol)
- Di-tert-butyl dicarbonate () (2.62 g, 12.0 mmol, 1.2 eq)
- Triethylamine (TEA) (1.53 mL, 11.0 mmol, 1.1 eq)
- 4-Dimethylaminopyridine (DMAP) (122 mg, 1.0 mmol, 0.1 eq)
- Dichloromethane (DCM) (anhydrous, 40 mL)

Step-by-Step Procedure:

- Setup: Flame-dry a 100 mL round-bottom flask (RBF) and purge with nitrogen. Add a magnetic stir bar.
- Dissolution: Charge the flask with 5-(trifluoromethoxy)indole (2.01 g) and anhydrous DCM (30 mL). Stir until fully dissolved.
- Base Addition: Add TEA (1.53 mL) and DMAP (122 mg) to the stirring solution. The mixture typically remains clear.
- Reagent Addition: Dissolve (2.62 g) in the remaining DCM (10 mL) and add it dropwise to the reaction mixture over 10 minutes.

- Note: Gas evolution () may be observed. Ensure the system is vented (e.g., via a needle and bubbler).
- Reaction: Stir at room temperature for 3–6 hours. Monitor via TLC (Hexane/EtOAc 9:1). The product will have a significantly higher than the starting indole.
- Workup:
 - Quench by adding water (30 mL).
 - Separate the organic layer.
 - Extract the aqueous layer with DCM (2 x 20 mL).
 - Wash combined organics with 0.5 M HCl (20 mL) to remove DMAP/TEA, followed by saturated (20 mL) and brine (20 mL).
- Isolation: Dry over anhydrous , filter, and concentrate in vacuo.
- Purification: If necessary, purify via flash column chromatography (Silica gel, 0-5% EtOAc in Hexanes). The product is often a low-melting solid or viscous oil.

Mechanistic Insight

The DMAP acts as an acyl transfer agent. It attacks

to form a highly electrophilic N-acylpyridinium salt. This species reacts much faster with the indole anion (generated by TEA equilibrium) than

alone, which is crucial given the electron-deficient nature of the 5-OCF

ring.

Pathway B: De Novo Synthesis (Fischer Indole)

Context: Required when the 5-trifluoromethoxy indole core is unavailable. This route builds the indole ring from the hydrazine precursor.^{[2][3][4][5]}

Reaction Scheme

Experimental Protocol

Scale: 20.0 mmol basis Reagents:

- 4-(Trifluoromethoxy)phenylhydrazine hydrochloride (4.57 g, 20.0 mmol)
- Acetaldehyde diethyl acetal (2.60 g, 22.0 mmol, 1.1 eq)
- Zinc Chloride (
) (anhydrous, 20.0 mmol) or 4%
- Solvent: Ethanol (Abs) or Toluene/Acetic Acid

Step-by-Step Procedure:

- Hydrazone Formation:
 - Dissolve the hydrazine salt (4.57 g) in Ethanol (40 mL).
 - Add acetaldehyde diethyl acetal (2.60 g).
 - Heat to reflux for 2 hours. Monitor the disappearance of hydrazine by TLC.^[6]
 - Concentrate to yield the crude hydrazone.
- Cyclization (Fischer Indolization):
 - Resuspend the crude hydrazone in Toluene (50 mL).
 - Add anhydrous
(2.7 g).

- Heat to reflux (110°C) with a Dean-Stark trap to remove water/ethanol. Stir vigorously for 4–8 hours.
- Observation: The reaction will darken significantly.
- Workup:
 - Cool to room temperature.[7]
 - Pour the mixture into ice-cold dilute HCl (0.5 M, 100 mL) to break up zinc complexes.
 - Extract with EtOAc (3 x 50 mL).
 - Wash combined organics with

and brine.
- Purification:
 - The crude material will contain regioisomers or polymerization byproducts.
 - Purify via column chromatography (Hexane/EtOAc gradient).
 - Yield Expectation: 40–60% (Fischer synthesis often suffers from moderate yields due to oligomerization).

Process Data & Troubleshooting

Parameter	Pathway A (Direct Protection)	Pathway B (De Novo Synthesis)
Overall Yield	85–95%	35–55%
Reaction Time	3–6 hours	12–24 hours (2 steps)
Key Risk	Hydrolysis of Boc group if workup is too acidic.	Regio-control and oligomerization during cyclization.
Purification	Simple filtration or short plug.	Careful chromatography required.
Cost Driver	Cost of 5-OCF3-Indole starting material.	Labor and purification time. ^[2] ^[6]

Troubleshooting the OCF Group

- Volatility: The OCF

group increases volatility. Do not dry the final product under high vacuum (< 1 mbar) for extended periods if the product is an oil; it may sublime or evaporate.

- Stability: The OCF

group is generally stable to acid (Fischer conditions) and mild base. Avoid extremely strong reducing agents (e.g.,

at high temps) which might defluorinate, though this is rare under standard conditions.

Mechanism of Action (Pathway A)

The following diagram illustrates the DMAP-catalyzed protection mechanism, highlighting the activation of the anhydride.

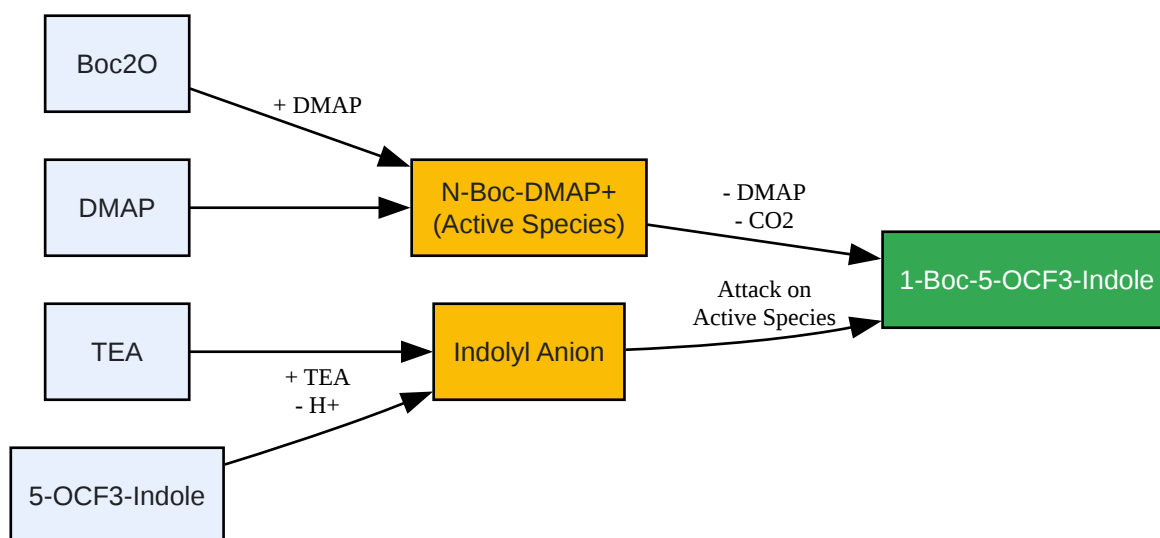

[Click to download full resolution via product page](#)

Figure 2: Catalytic cycle of DMAP-mediated Boc protection.

References

- Sigma-Aldrich. 5-(Trifluoromethoxy)-1H-indole Product Page. (CAS 262593-63-5).[1]
Retrieved from
- Greene, T. W., & Wuts, P. G. M. (2014). Greene's Protective Groups in Organic Synthesis. John Wiley & Sons. (Standard protocols for Boc protection of electron-deficient amines).
- Robinson, B. (1982).[5] The Fischer Indole Synthesis. Wiley-Interscience. (Definitive text on Fischer cyclization mechanisms and conditions).
- BenchChem. Fischer Indole Synthesis: A Comprehensive Technical Guide. Retrieved from
- ChemicalBook. 4-(Trifluoromethoxy)phenylhydrazine hydrochloride Product Data. (CAS 461-17-6). Retrieved from

Need Custom Synthesis?

BenchChem offers custom synthesis for rare earth carbides and specific isotopic labeling.

Email: info@benchchem.com or [Request Quote Online](#).

Sources

- [1. 5-Trifluoromethoxy-1H-indole | 262593-63-5 \[chemicalbook.com\]](#)
- [2. pdf.benchchem.com \[pdf.benchchem.com\]](#)
- [3. Fischer indole synthesis - Wikipedia \[en.wikipedia.org\]](#)
- [4. alfa-chemistry.com \[alfa-chemistry.com\]](#)
- [5. Organic Syntheses Procedure \[orgsyn.org\]](#)
- [6. mdpi.com \[mdpi.com\]](#)
- [7. 5-\(Trifluoromethyl\)indole | 100846-24-0 \[chemicalbook.com\]](#)
- To cite this document: BenchChem. [1-BOC-5-Trifluoromethoxy Indole: Synthesis & Process Guide]. BenchChem, [2026]. [Online PDF]. Available at: [\[https://www.benchchem.com/product/b1526916/docs#1-boc-5-trifluoromethoxy-indole-synthesis-process-guide\]](https://www.benchchem.com/product/b1526916/docs#1-boc-5-trifluoromethoxy-indole-synthesis-process-guide)

Disclaimer & Data Validity:

The information provided in this document is for Research Use Only (RUO) and is strictly not intended for diagnostic or therapeutic procedures. While BenchChem strives to provide accurate protocols, we make no warranties, express or implied, regarding the fitness of this product for every specific experimental setup.

Technical Support: The protocols provided are for reference purposes. Unsure if this reagent suits your experiment?

Need Industrial/Bulk Grade? [Request Custom Synthesis Quote](#)

BenchChem

Our mission is to be the trusted global source of essential and advanced chemicals, empowering scientists and researchers to drive progress in science and industry.

Contact

Address: 3281 E Guasti Rd
Ontario, CA 91761, United States
Phone: (601) 213-4426
Email: info@benchchem.com

Contact our Ph.D. Support Team for a compatibility check