

Introduction: Unlocking New Synthetic Pathways with a Multifunctional Building Block

Author: BenchChem Technical Support Team. **Date:** April 2026

Compound of Interest

Compound Name: 3-[(Benzenesulfinyl)methyl]aniline

CAS No.: 1250005-39-0

Cat. No.: B1525485

[Get Quote](#)

Heterocyclic compounds form the bedrock of medicinal chemistry, with a vast majority of FDA-approved drugs featuring these structural motifs.[1] Their prevalence stems from their ability to present functional groups in well-defined three-dimensional space, enabling precise interactions with biological targets.[2] The ongoing quest for novel therapeutic agents continually drives the demand for innovative synthetic methodologies and unique molecular building blocks that allow for the efficient construction of diverse heterocyclic libraries.

This guide introduces **3-[(Benzenesulfinyl)methyl]aniline**, a promising yet under-explored reagent for heterocyclic synthesis. Its unique trifunctional architecture—comprising a nucleophilic aniline core, an activating and potentially chiral benzenesulfinyl moiety, and a reactive benzylic methylene group—positions it as a powerful tool for assembling complex molecular frameworks. The sulfinyl group, in particular, imparts distinct electronic and steric properties. As an electron-withdrawing group, it modulates the reactivity of the aniline ring and acidifies the adjacent methylene protons. Furthermore, the sulfur atom is a stereocenter, offering intriguing possibilities for asymmetric synthesis and the introduction of chirality.

This document serves as a senior application scientist's perspective on the potential applications of **3-[(Benzenesulfinyl)methyl]aniline**. We will move beyond simple procedural

lists to explore the mechanistic rationale behind its proposed use in cornerstone synthetic transformations for building quinoline and tetrahydroisoquinoline skeletons—two scaffolds of immense pharmaceutical importance.

Application 1: Synthesis of Substituted Quinolines via Combes-type Annulation

The quinoline ring system is a privileged scaffold found in numerous pharmaceuticals, including antiviral, anticancer, and antimalarial agents.[3] The Combes synthesis is a classic acid-catalyzed reaction that constructs the quinoline core by condensing an aniline with a 1,3-dicarbonyl compound.[4] We propose a Combes-type protocol where **3-[(Benzenesulfinyl)methyl]aniline** can be used to generate novel 7-[(benzenesulfinyl)methyl]quinolines.

Causality and Mechanistic Insight

The reaction is initiated by the nucleophilic attack of the aniline amine onto one of the carbonyl groups of the β -ketoester (e.g., ethyl acetoacetate), forming a β -amino acrylate intermediate after dehydration. The key to the Combes synthesis is the subsequent intramolecular electrophilic cyclization onto the aromatic ring, which is typically performed under strong acidic conditions to protonate the enamine and activate the ring closure. The final step involves dehydration to furnish the aromatic quinoline ring. The electron-withdrawing nature of the benzenesulfinyl group is expected to deactivate the aniline ring towards electrophilic substitution, necessitating robust acidic catalysis (e.g., polyphosphoric acid or concentrated sulfuric acid) to drive the cyclization step to completion.

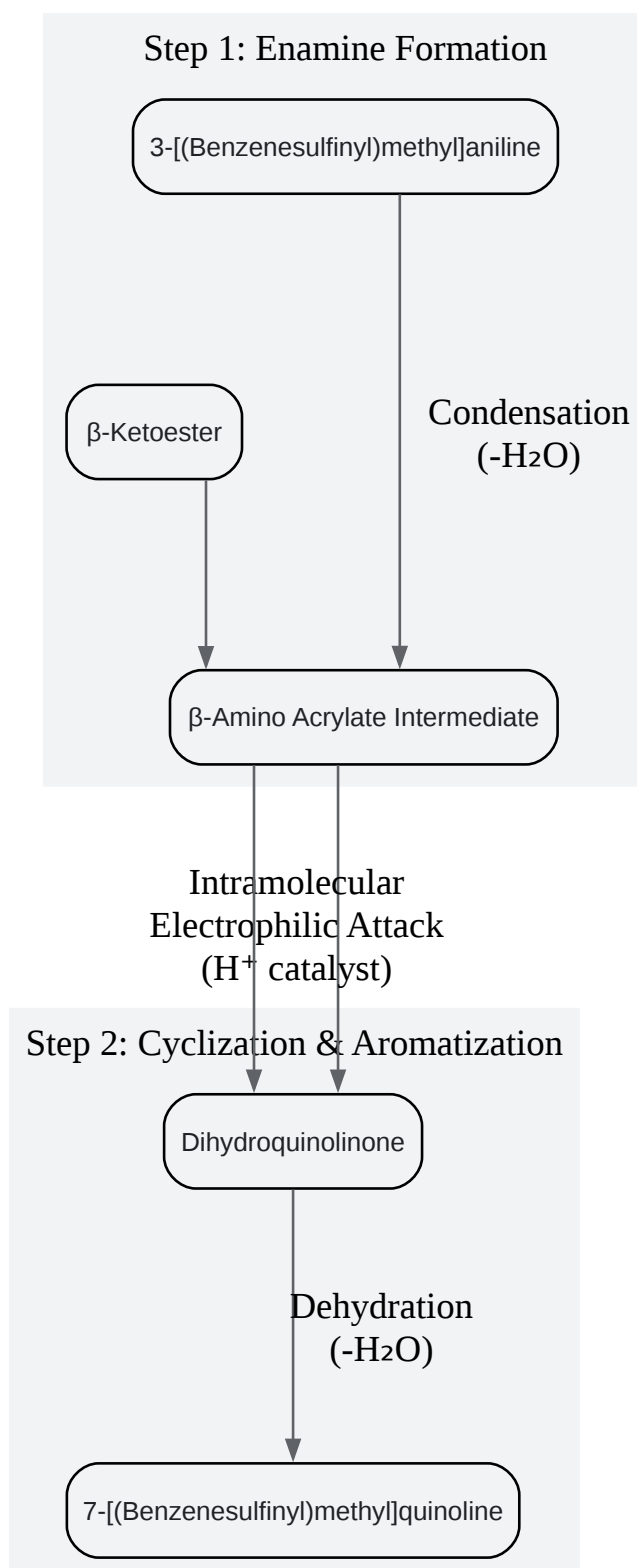

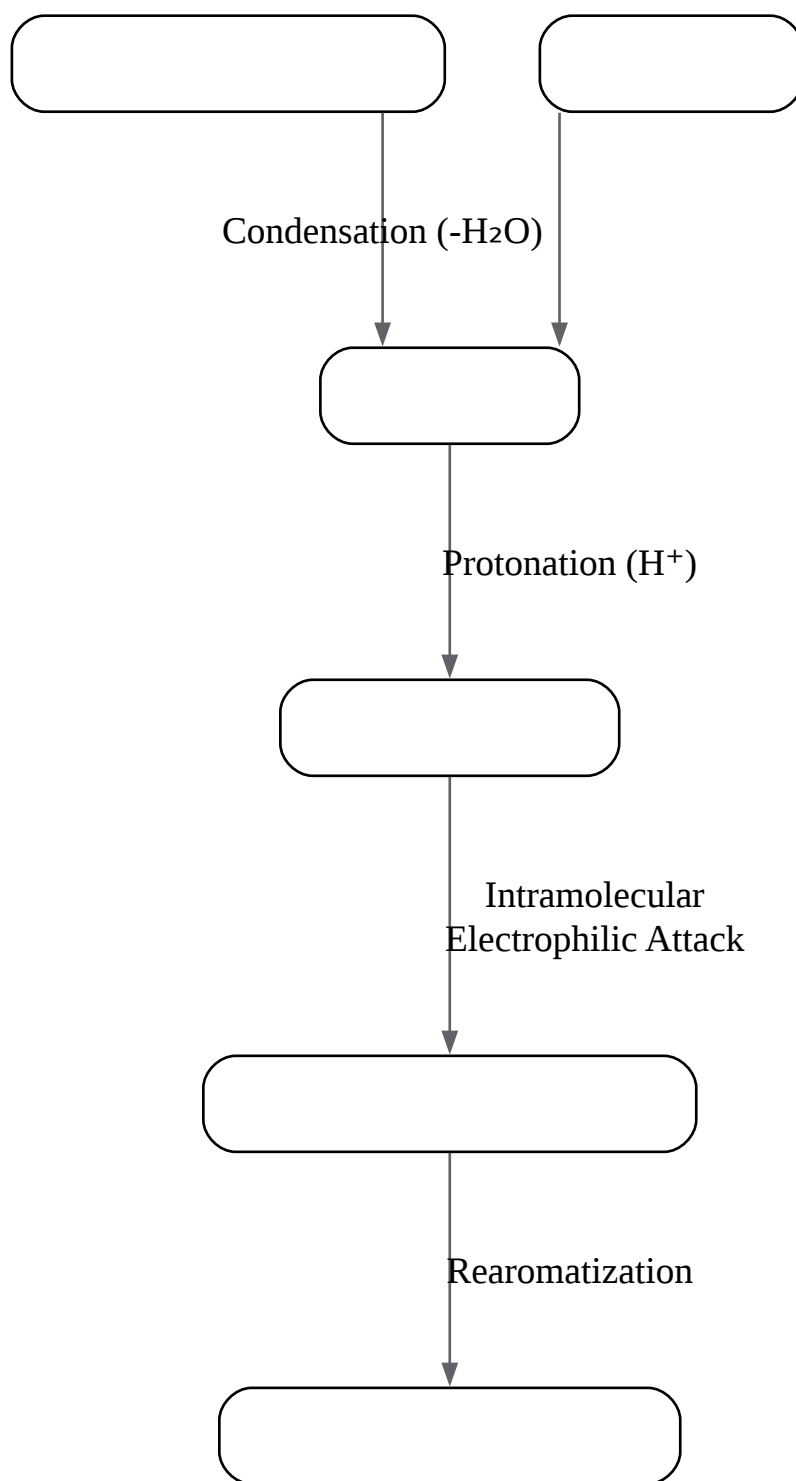

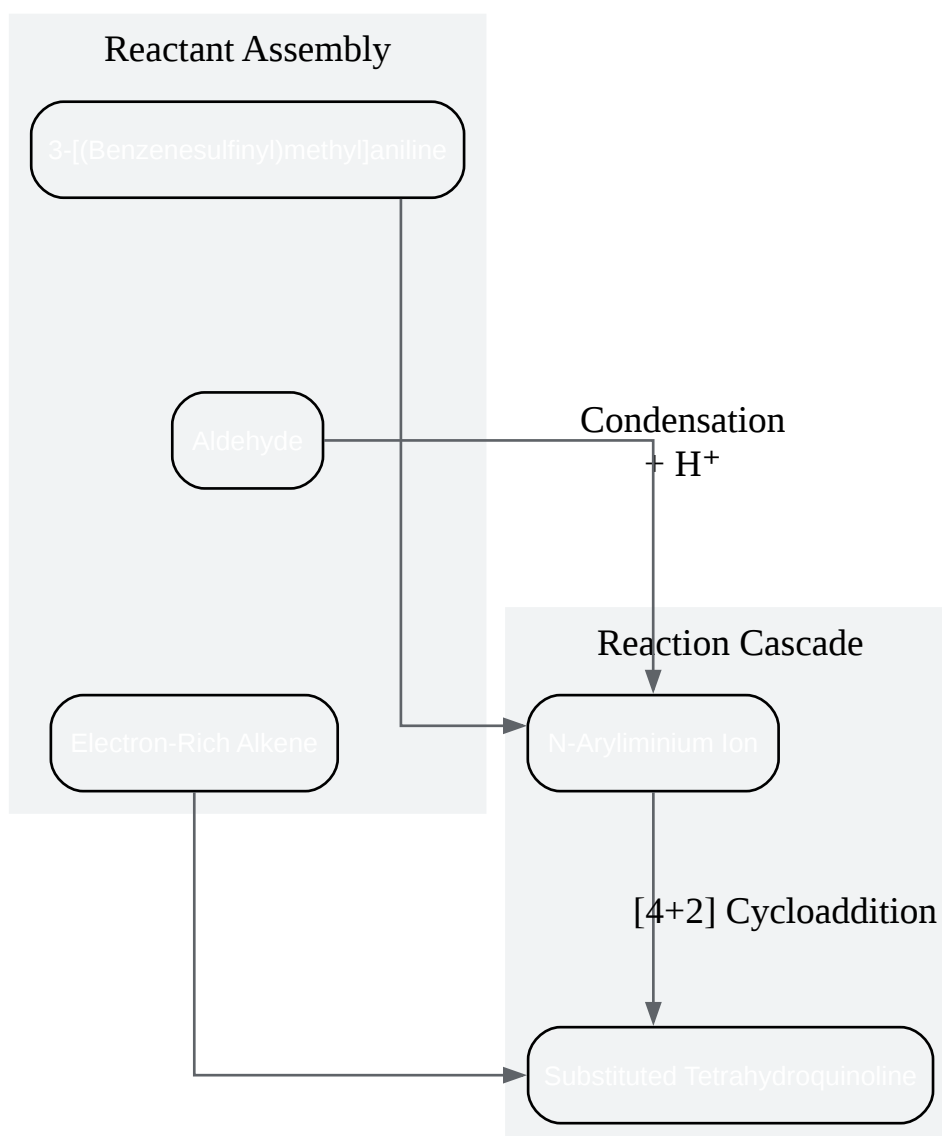

[Click to download full resolution via product page](#)

Need Custom Synthesis?

BenchChem offers custom synthesis for rare earth carbides and specific isotopic labeling.

Email: info@benchchem.com or [Request Quote Online](#).

Sources

- 1. deepblue.lib.umich.edu [deepblue.lib.umich.edu]

- [2. Catalysis for Heterocycles Chemistry – The Soulé Research Group \[souleresearchgroup.org\]](#)
- [3. researchgate.net \[researchgate.net\]](#)
- [4. Synthesis, Reactions and Medicinal Uses of Quinoline | Pharmaguideline \[pharmaguideline.com\]](#)
- To cite this document: BenchChem. [Introduction: Unlocking New Synthetic Pathways with a Multifunctional Building Block]. BenchChem, [2026]. [Online PDF]. Available at: [\[https://www.benchchem.com/product/b1525485/docs#introduction-unlocking-new-synthetic-pathways-with-a-multifunctional-building-block\]](https://www.benchchem.com/product/b1525485/docs#introduction-unlocking-new-synthetic-pathways-with-a-multifunctional-building-block)

Disclaimer & Data Validity:

The information provided in this document is for Research Use Only (RUO) and is strictly not intended for diagnostic or therapeutic procedures. While BenchChem strives to provide accurate protocols, we make no warranties, express or implied, regarding the fitness of this product for every specific experimental setup.

Technical Support: The protocols provided are for reference purposes. Unsure if this reagent suits your experiment?

Need Industrial/Bulk Grade? [Request Custom Synthesis Quote](#)

BenchChem

Our mission is to be the trusted global source of essential and advanced chemicals, empowering scientists and researchers to drive progress in science and industry.

Contact

Address: 3281 E Guasti Rd
Ontario, CA 91761, United States
Phone: (601) 213-4426
Email: info@benchchem.com

Contact our Ph.D. Support Team for a compatibility check