

# Comprehensive Characterization of 2-Bromo-5-methyl-4-phenylpyridine: A Technical Guide

**Author:** BenchChem Technical Support Team. **Date:** April 2026

## Compound of Interest

Compound Name: 2-Bromo-5-methyl-4-phenylpyridine

Cat. No.: B15248671

[Get Quote](#)

Target Audience: Analytical Chemists, Synthetic Methodologists, and Drug Development Professionals  
Compound CAS: 1438809-95-0

## Introduction & Structural Rationale

Halogenated phenylpyridines are indispensable building blocks in modern organic synthesis, serving as highly chemo-selective scaffolds for cross-coupling reactions and the development of diverse molecular architectures[1]. Specifically, **2-Bromo-5-methyl-4-phenylpyridine** presents a unique 2,4,5-substitution pattern that is highly valued in the synthesis of OLED materials and pharmaceutical active pharmaceutical ingredients (APIs).

As a Senior Application Scientist, I approach the characterization of such heterocycles not merely as a checklist of analytical techniques, but as a cohesive, self-validating system. The presence of the electron-withdrawing bromine at C-2, the sterically demanding phenyl group at C-4, and the electron-donating methyl group at C-5 creates a complex electronic environment. Unambiguous structural elucidation requires an orthogonal analytical workflow combining Nuclear Magnetic Resonance (NMR) spectroscopy and High-Resolution Mass Spectrometry (HRMS).

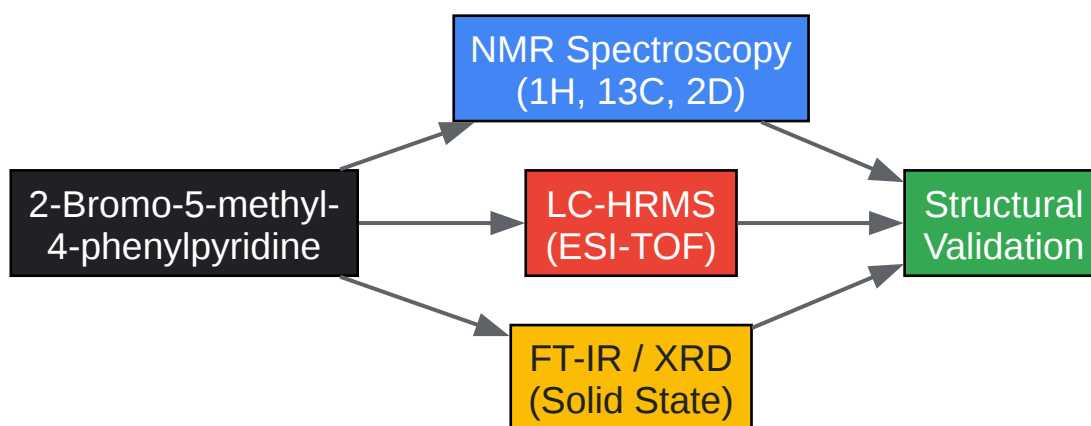

[Click to download full resolution via product page](#)

Fig 1. Multidimensional analytical workflow for pyridine derivative validation.

## Nuclear Magnetic Resonance (NMR) Profiling

NMR spectroscopy is the foundational technique for characterizing pyridine derivatives, providing exact spatial and electronic connectivity[2]. The diamagnetic anisotropy of the pyridine ring, combined with the inductive effects of the heteroatom, dictates the chemical shifts of the attached protons and carbons.

### Causality in Chemical Shifts

The

-protons of a pyridine ring (C2, C6) are heavily deshielded due to their proximity to the electronegative nitrogen atom, typically appearing furthest downfield (

8.5–8.8 ppm)[2]. In **2-Bromo-5-methyl-4-phenylpyridine**, C2 is substituted by bromine, leaving only H-6 in the

-position. Because H-6 is isolated by the C5-methyl group, it appears as a sharp singlet. Similarly, H-3 is isolated between the C2-bromine and the C4-phenyl group, appearing as a distinct singlet further upfield.

Advanced characterization of such scaffolds may also employ

N NMR, as the electronic properties of the sp

-hybridized nitrogen are highly sensitive to its local chemical environment and protonation state[3].

## Quantitative Data Summaries

Table 1: Predicted

H NMR Assignments (400 MHz, CDCl<sub>3</sub>)

Position	Chemical Shift ( , ppm)	Multiplicity	Integration	Assignment Rationale
H-6	8.25	Singlet (s)	1H	Highly deshielded -proton adjacent to the pyridine nitrogen.
H-3	7.50	Singlet (s)	1H	Isolated -proton situated between the Br and Phenyl substituents.
Phenyl-H	7.45 - 7.35	Multiplet (m)	5H	Overlapping aromatic protons of the freely rotating C4-phenyl ring.
CH (C-5)	2.30	Singlet (s)	3H	Aliphatic methyl group attached to the heteroaromatic core.

Table 2: Predicted

C NMR Assignments (100 MHz, CDCl<sub>3</sub>)

Position	Chemical Shift ( , ppm)	Type	Assignment Rationale
C-6	150.5	CH	-carbon to nitrogen; strong inductive deshielding.
C-4	148.0	Cq	Quaternary carbon conjugated directly with the phenyl ring.
C-2	142.5	Cq	Quaternary carbon bonded to the electronegative bromine atom.
C-1' (Ph)	137.5	Cq	Ipso-carbon of the phenyl substituent.
C-5	131.0	Cq	Quaternary carbon bonded to the electron-donating methyl group.
Ph-CH	129.0, 128.5, 128.0	CH	Ortho, meta, and para carbons of the phenyl ring.
C-3	126.5	CH	-carbon to nitrogen; relatively shielded compared to C-2/C-6.
CH	19.5	CH	Aliphatic methyl carbon.

## Mass Spectrometry & Isotopic Fingerprinting

While NMR provides connectivity, Liquid Chromatography-High Resolution Mass Spectrometry (LC-HRMS) confirms the exact molecular formula and reveals diagnostic fragmentation patterns. The proton affinity of a pyridine core is typically decreased by 5–15 kJ/mol upon halogenation, which subtly influences its ionization efficiency in positive Electrospray Ionization (ESI+)[4].

### The Bromine Isotopic Signature

Bromine naturally occurs as two stable isotopes (

Br and

Br) in a nearly 1:1 ratio. Consequently, the mass spectrum of **2-Bromo-5-methyl-4-phenylpyridine** (Exact Mass: 246.9997 Da) will exhibit a highly diagnostic doublet for the [M+H]

precursor ion at  $m/z$  248.0 and  $m/z$  250.0 of equal intensity.

### Collision-Induced Dissociation (CID) Pathways

Upon collisional activation in the MS/MS cell, protonated halogenated pyridines readily undergo dehalogenation[4]. This phenomenon is often driven by the formation of a lower-lying triplet state during interaction with the collision gas, leading to an almost spontaneous loss of the halogen radical or HX[4].

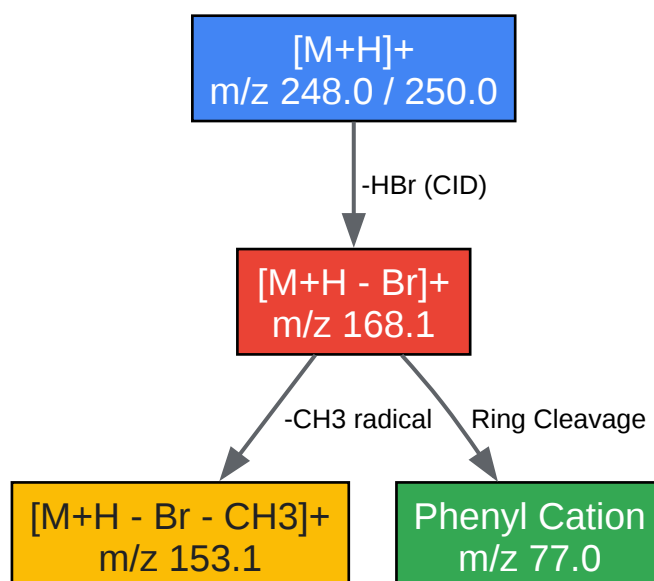

[Click to download full resolution via product page](#)

Fig 2. Proposed collision-induced dissociation (CID) pathway for the target molecule.

## Validated Experimental Protocols

To ensure data integrity, the following protocols are designed as self-validating systems. Every step includes a mechanistic rationale and a system suitability check.

### NMR Acquisition Protocol

- Rationale: Quaternary carbons (C2, C4, C5, C1') lack attached protons, meaning they rely on less efficient dipole-dipole interactions for spin-lattice relaxation ( ). If the relaxation delay is too short, these critical signals will be artificially suppressed or missing from the C spectrum.
- Step 1: Dissolve 15–20 mg of the analyte in 0.6 mL of CDCl<sub>3</sub> containing 0.03% v/v Tetramethylsilane (TMS) as an internal reference. Transfer to a high-quality 5 mm NMR tube.
- Step 2: Load into a 400 MHz (or higher) NMR spectrometer equilibrated at 298 K. Tune and match the probe to the specific sample impedance.

- Step 3 (

H NMR): Acquire 16 scans using a standard 90° pulse sequence (zg30) with a relaxation delay (D1) of 1.0 second.

- Step 4 (

C NMR): Acquire 1024 scans using power-gated broadband proton decoupling (zgpg30). Crucially, extend the D1 delay to 2.5–3.0 seconds to ensure full relaxation and quantitative integration of the quaternary carbons.

- Self-Validation Check: The residual CHCl

solvent peak must appear exactly at

7.26 ppm (

H) and

77.16 ppm (

C). The line shape of the TMS peak (measured at 50% and 0.55% peak height) must meet manufacturer specifications to confirm magnetic field homogeneity. Poor shimming will artificially broaden the diagnostic H-3 and H-6 singlets, rendering them indistinguishable from multiplets.

## LC-HRMS/MS Acquisition Protocol

- Rationale: ESI+ is ideal for basic pyridine nitrogens. A soft gradient ensures the analyte is separated from any unreacted starting materials (e.g., phenylboronic acid from a Suzuki coupling) before entering the source, preventing ion suppression.
- Step 1: Dilute the sample to a final concentration of 1 µg/mL in LC-MS grade Methanol/Water (50:50) containing 0.1% Formic Acid (to promote protonation).
- Step 2: Inject 2 µL onto a C18 UPLC column (e.g., 50 x 2.1 mm, 1.7 µm particle size). Elute using a linear gradient of 5% to 95% Acetonitrile (with 0.1% Formic Acid) over 5 minutes.
- Step 3: Operate the mass spectrometer in ESI+ mode. Set the capillary voltage to 3.0 kV, desolvation temperature to 350 °C, and scan range from m/z 100 to 500.

- Step 4: For MS/MS (CID), isolate the m/z 248.0 precursor ion and apply a collision energy ramp of 15–30 eV using Nitrogen or Argon as the collision gas to induce dehalogenation[4].
- Self-Validation Check: Prior to sample injection, the mass spectrometer must be calibrated using a standard tuning mix to achieve mass accuracy < 5 ppm. A solvent blank must be run immediately before the sample to rule out carryover or background contamination at the target m/z.

## References

- Application Notes and Protocols for NMR Spectroscopy of Pyridine Deriv
- Hyperpolarized <sup>15</sup>N-pyridine Deriv
- Collisional activation of protonated halogeno-pyridines: different behaviour of target gases - KU Leuven.
- Halogenated Phenylpyridines Possessing Chemo-Selectivity for Diverse Molecular Architectures - NIH.

### Need Custom Synthesis?

BenchChem offers custom synthesis for rare earth carbides and specific isotopic labeling.

Email: [info@benchchem.com](mailto:info@benchchem.com) or [Request Quote Online](#).

## Sources

- 1. Halogenated Phenylpyridines Possessing Chemo-Selectivity for Diverse Molecular Architectures - PMC [[pmc.ncbi.nlm.nih.gov](https://pubmed.ncbi.nlm.nih.gov/)]
- 2. [pdf.benchchem.com](https://pdf.benchchem.com) [[pdf.benchchem.com](https://pdf.benchchem.com)]
- 3. Hyperpolarized <sup>15</sup>N-pyridine Derivatives as pH-Sensitive MRI Agents - PMC [[pmc.ncbi.nlm.nih.gov](https://pubmed.ncbi.nlm.nih.gov/)]
- 4. [quantchem.kuleuven.be](https://quantchem.kuleuven.be) [[quantchem.kuleuven.be](https://quantchem.kuleuven.be)]
- To cite this document: BenchChem. [Comprehensive Characterization of 2-Bromo-5-methyl-4-phenylpyridine: A Technical Guide]. BenchChem, [2026]. [Online PDF]. Available at: [<https://www.benchchem.com/product/b15248671/docs#comprehensive-characterization-of-2-bromo-5-methyl-4-phenylpyridine-a-technical-guide>]

### Disclaimer & Data Validity:

The information provided in this document is for Research Use Only (RUO) and is strictly not intended for diagnostic or therapeutic procedures. While BenchChem strives to provide accurate protocols, we make no warranties, express or implied, regarding the fitness of this product for every specific experimental setup.

**Technical Support:** The protocols provided are for reference purposes. Unsure if this reagent suits your experiment?

**Need Industrial/Bulk Grade?** [Request Custom Synthesis Quote](#)

## BenchChem

Our mission is to be the trusted global source of essential and advanced chemicals, empowering scientists and researchers to drive progress in science and industry.

### Contact

Address: 3281 E Guasti Rd  
Ontario, CA 91761, United States  
Phone: (601) 213-4426  
Email: [info@benchchem.com](mailto:info@benchchem.com)

[Contact our Ph.D. Support Team for a compatibility check](#)