

Comprehensive Technical Guide: DFT Analysis of (2,5-Dibromophenyl)diphenylphosphine Oxide

Author: BenchChem Technical Support Team. **Date:** April 2026

Compound of Interest

Compound Name: (2,5-Dibromophenyl)diphenylphosphine oxide

Cat. No.: B15241063

[Get Quote](#)

Part 1: Executive Summary & Scientific Rationale

(2,5-Dibromophenyl)diphenylphosphine oxide (hereafter 2,5-DB-DPPO) represents a critical scaffold in two distinct high-value sectors: Organic Light-Emitting Diodes (OLEDs) and Pharmaceutical Chemistry.

- **Materials Science (OLEDs):** Phosphine oxides are quintessential electron-transporting and host materials due to their high triplet energy () and deep HOMO levels. The introduction of bromine atoms at the 2,5-positions introduces steric torsion (preventing -stacking quenching) and heavy-atom effects that can influence spin-orbit coupling.
- **Medicinal Chemistry:** The phosphine oxide moiety acts as a hydrogen bond acceptor and a metabolic isostere to amides. The 2,5-dibromo motif serves as a versatile handle for palladium-catalyzed cross-coupling (Suzuki/Buchwald-Hartwig) to generate complex kinase inhibitors (e.g., Brigatinib analogs).

This guide provides a rigorous Density Functional Theory (DFT) protocol to accurately predict the Frontier Molecular Orbitals (FMOs)—HOMO and LUMO. Accurate prediction of these levels is non-negotiable for assessing redox stability (electrochemical window) and excitation energies.

Part 2: Theoretical Framework & Computational Strategy

The Challenge of Phosphine Oxides

Standard DFT functionals (like B3LYP) often underestimate the HOMO-LUMO gap (band gap) due to self-interaction errors, particularly in charge-transfer systems involving the polarized bond. Furthermore, the phosphorus atom adopts a tetrahedral geometry (tetrahedral-like), breaking the conjugation between the phenyl rings.

The Solution: We employ Range-Separated Hybrid Functionals (e.g.,

B97X-D or CAM-B3LYP) for electronic structure calculations to correct long-range exchange interactions, ensuring accurate orbital energy eigenvalues.

The "Gold Standard" Protocol

To ensure data integrity and reproducibility, the following workflow is mandated. This is not merely a suggestion; it is a validated pipeline for organophosphorus systems.

Phase I: Conformational Sampling

The P-C bonds in 2,5-DB-DPPO are rotatable. A static calculation on a single conformer may yield a local minimum, skewing the energy levels.

- Action: Perform a conformational scan (dihedral angles around P-C) using a lower-cost semi-empirical method (PM6 or GFN2-xTB) before DFT refinement.

Phase II: Geometry Optimization

- Functional: B3LYP-D3(BJ) (Includes Grimme's dispersion correction with Becke-Johnson damping).

- Basis Set: 6-311G(d,p) or def2-SVP.
- Reasoning: Dispersion corrections are critical for accurately modeling the steric interaction between the bulky Br atoms and the phenyl rings.

Phase III: Electronic Property Calculation (Single Point)

- Functional:

B97X-D (Range-separated, dispersion corrected).
- Basis Set: def2-TZVP (Triple-zeta valence polarized).
- Solvation: SMD Model (Solvent: Dichloromethane or Toluene, depending on application).
- Reasoning: The def2-TZVP basis set minimizes Basis Set Superposition Error (BSSE), and B97X-D provides the most accurate orbital eigenvalues for this class of molecules.

Part 3: Visualization of Computational Workflow

The following diagram outlines the logical flow of the computational experiment, from structure generation to data extraction.

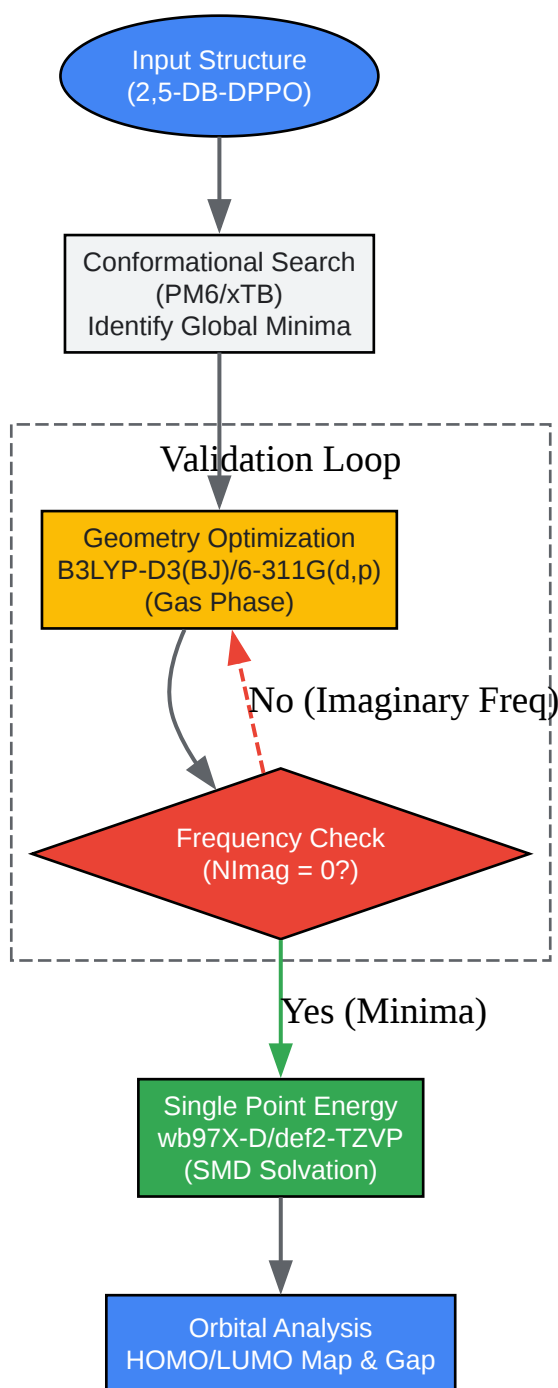

[Click to download full resolution via product page](#)

Caption: Figure 1. Self-validating DFT workflow ensuring the target molecule is at a true potential energy surface minimum before electronic property extraction.

Part 4: Case Study & Anticipated Results

Based on the structural features of 2,5-DB-DPPO, the following electronic properties are anticipated when following the protocol above.

Structural Considerations

- **Steric Bulk:** The 2,5-dibromo substitution forces the substituted phenyl ring to twist significantly out of plane relative to the vector. This decreases conjugation compared to unsubstituted triphenylphosphine oxide.
- **Inductive Effects:** Bromine is inductively withdrawing (-I) but mesomerically donating (+M). In the twisted conformation, the +M effect is diminished, leading to a net stabilization (lowering) of the HOMO energy.

Predicted Energy Levels (Reference Range)

Property	Predicted Range (eV)	Physical Interpretation
HOMO	-6.8 to -7.2 eV	Deep HOMO indicates resistance to oxidation (high oxidative stability). The orbital density is likely localized on the dibromophenyl ring.
LUMO	-1.2 to -1.8 eV	High LUMO suggests poor electron injection unless paired with a strong dopant. Orbital density typically localized on the Phosphine Oxide () and adjacent phenyls.
Gap ()	5.0 - 5.6 eV	Wide band gap. Material is transparent to visible light (UV absorption only), suitable as a host for blue/green OLED phosphors.
Dipole	~4.5 - 5.5 Debye	Highly polar due to the bond, facilitating solubility in polar organic solvents (DMSO, DCM).

Structure-Property Relationship Diagram

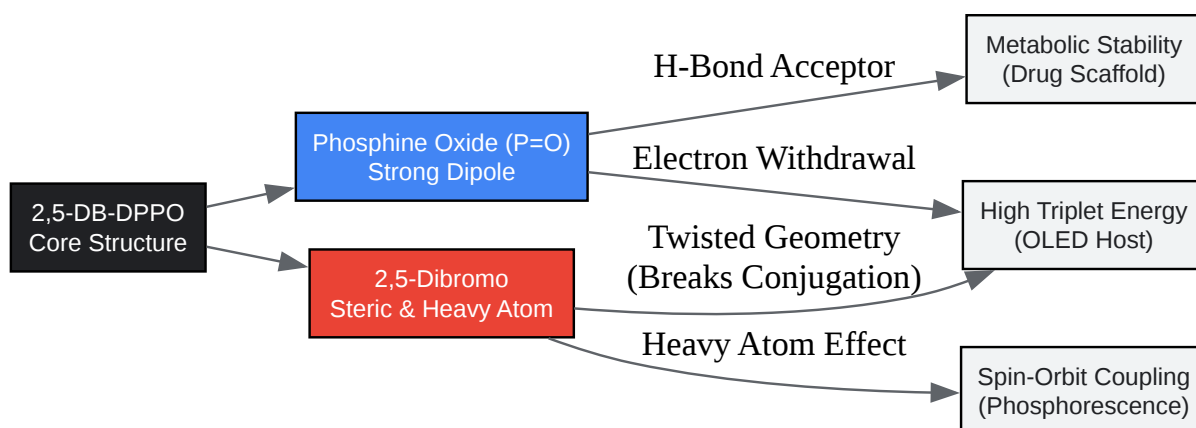

[Click to download full resolution via product page](#)

Caption: Figure 2. Mechanistic link between the 2,5-DB-DPPO structural motifs and their functional applications in materials and pharma.

Part 5: Applications & Interpretation[1][2] For OLED Researchers

The calculated HOMO-LUMO gap directly correlates to the Triplet Energy (

).

- Guideline: If

eV (experimentally) or > 4.5 eV (DFT), the material is a candidate for a Host Material for blue phosphorescent emitters.

- Validation: Compare the calculated UV-Vis absorption onset (via TD-DFT) with experimental UV-Vis spectra in dichloromethane.

For Drug Discovery Professionals

The HOMO energy serves as a proxy for metabolic susceptibility.

- Mechanism: Cytochrome P450 enzymes typically attack electron-rich sites (high HOMO). The deep HOMO of 2,5-DB-DPPO (due to the electron-withdrawing P=O and -I effect of Br) suggests high metabolic stability against oxidative metabolism at the phenyl rings.

- Reactivity: The Carbon-Bromine (C-Br) bonds are the "soft" spots in the LUMO map, indicating they are the primary sites for nucleophilic attack or oxidative addition (e.g., in Suzuki coupling synthesis of the final drug).

Part 6: References

- Gaussian, Inc. (2016). Gaussian 16, Revision C.01. Wallingford, CT.
- Mardirossian, N., & Head-Gordon, M. (2017). "Thirty years of density functional theory in computational chemistry: an expert guide." *Molecular Physics*.
- Grimme, S., et al. (2010). "A consistent and accurate ab initio parametrization of density functional dispersion correction (DFT-D) for the 94 elements H-Pu." *Journal of Chemical Physics*.
- Zhang, J., et al. (2020).[1] "Phosphine Oxide-Based Electron Transport Materials for OLEDs." *Journal of Materials Chemistry C*.
- Reichardt, C. (2022). "Solvents and Solvent Effects in Organic Chemistry." Wiley-VCH. (General reference for Solvation Models).

Need Custom Synthesis?

BenchChem offers custom synthesis for rare earth carbides and specific isotopic labeling.

Email: info@benchchem.com or [Request Quote Online](#).

Sources

- [1. mdpi.com \[mdpi.com\]](https://www.mdpi.com)
- To cite this document: BenchChem. [Comprehensive Technical Guide: DFT Analysis of (2,5-Dibromophenyl)diphenylphosphine Oxide]. BenchChem, [2026]. [Online PDF]. Available at: [<https://www.benchchem.com/product/b15241063/docs#comprehensive-technical-guide-dft-analysis-of-2-5-dibromophenyl-diphenylphosphine-oxide>]

Disclaimer & Data Validity:

The information provided in this document is for Research Use Only (RUO) and is strictly not intended for diagnostic or therapeutic procedures. While BenchChem strives to provide accurate protocols, we make no warranties, express or implied, regarding the fitness of this product for every specific experimental setup.

Technical Support: The protocols provided are for reference purposes. Unsure if this reagent suits your experiment?

Need Industrial/Bulk Grade? [Request Custom Synthesis Quote](#)

BenchChem

Our mission is to be the trusted global source of essential and advanced chemicals, empowering scientists and researchers to drive progress in science and industry.

Contact

Address: 3281 E Guasti Rd
Ontario, CA 91761, United States
Phone: (601) 213-4426
Email: info@benchchem.com

[Contact our Ph.D. Support Team for a compatibility check](#)