

# Advanced Technical Guide: Piperidinyl Benzamide Intermediates in Medicinal Chemistry

**Author:** BenchChem Technical Support Team. **Date:** May 2026

## Compound of Interest

**Compound Name:** 4-Amino-2-(piperidin-1-yl)benzamide

**CAS No.:** 1311316-53-6

**Cat. No.:** B1524481

[Get Quote](#)

## Executive Summary

The piperidinyl benzamide scaffold represents a privileged pharmacophore in medicinal chemistry, serving as the structural backbone for a generation of high-affinity ligands targeting G-protein coupled receptors (GPCRs), particularly 5-HT

agonists (e.g., Cisapride, Prucalopride, Renzapride) and D

antagonists.<sup>[1]</sup>

This technical guide provides a rigorous analysis of the synthetic pathways, process optimization strategies, and critical quality attributes (CQAs) required for the production of these intermediates. Unlike generic reviews, this document focuses on the chemical engineering of the amide bond formation between the substituted benzoic acid and the aminopiperidine moieties—the rate-limiting step in defining yield and purity.<sup>[1]</sup>

## Structural Classification & Pharmacological Logic

The core structure consists of two distinct domains linked by an amide bond.[1] The biological activity is governed by the "lock-and-key" fit of these domains into the receptor binding pocket.

## The Pharmacophore[1]

- Domain A (Benzamide): Typically a 4-amino-5-chloro-2-methoxybenzoic acid derivative.[2] The 5-chloro and 2-methoxy groups are critical for inducing a specific torsion angle in the amide bond, facilitating hydrogen bonding with receptor residues (e.g., Serine/Threonine in 5-HT).  
)
- Domain B (Piperidine): A 4-aminopiperidine ring, often -substituted with bulky lipophilic groups (benzyl, phenethyl, or methoxypropyl) to interact with the hydrophobic accessory pocket of the receptor.[1]

## Retrosynthetic Analysis

The most robust synthetic strategy relies on a convergent approach, disconnecting the molecule at the amide linkage.[1]

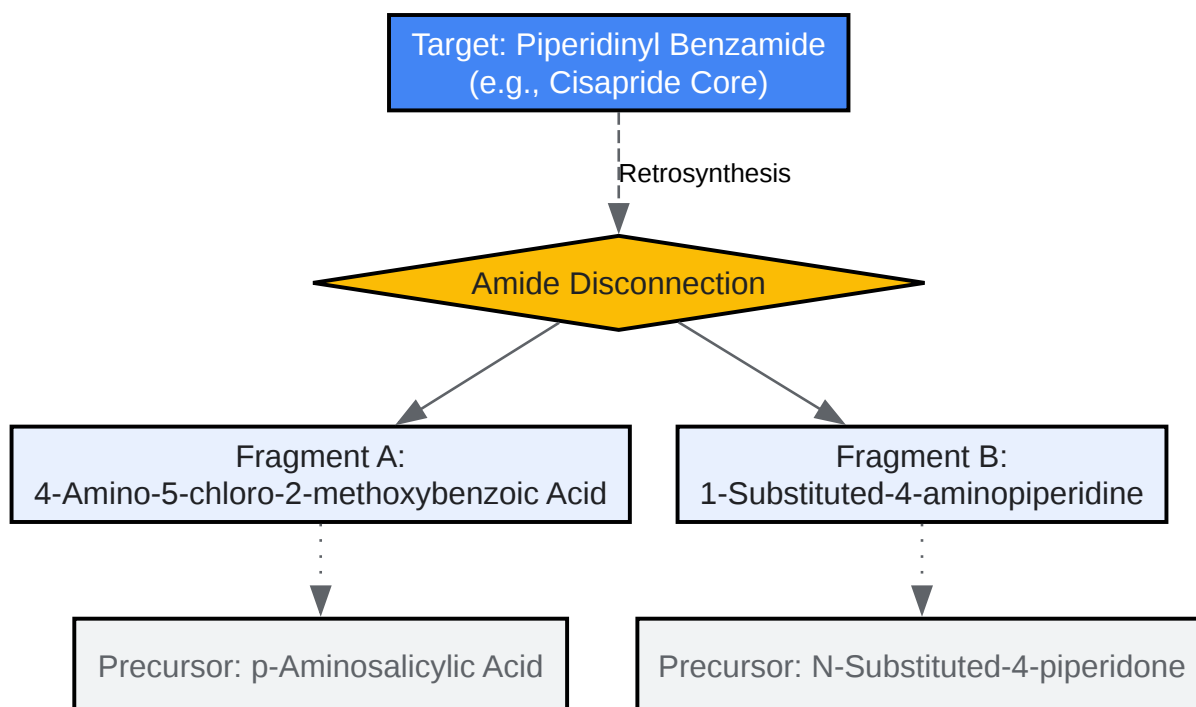

[Click to download full resolution via product page](#)

Figure 1: Convergent retrosynthetic analysis of the piperidinyl benzamide scaffold.

## Synthetic Strategies: The Amide Coupling Core[1]

The formation of the amide bond is the critical process step.[1] Three primary routes exist, each with distinct advantages regarding scalability and impurity profiles.[1][3][4]

### Route A: The Acid Chloride Method (Traditional)

This method involves converting the benzoic acid to its acid chloride using thionyl chloride ( ), followed by reaction with the amine.[1]

- Pros: High reactivity; low reagent cost.
- Cons: Generates HCl gas; requires protection of the 4-amino group on the benzamide (often as an acetamide) to prevent self-polymerization; harsh conditions can degrade sensitive -substituents on the piperidine.

### Route B: Mixed Anhydride Activation (Scalable & Mild)

Used in the synthesis of Prucalopride, this method uses ethyl chloroformate to generate a mixed anhydride in situ.[1]

- Mechanism: The carboxylic acid is treated with ethyl chloroformate and a base (TEA) to form a reactive anhydride, which is then attacked by the piperidinyl amine.[1]
- Pros: Mild conditions (0–25°C); no protection of the aniline nitrogen is strictly required if stoichiometry is controlled; easy workup.[1]
- Cons: Temperature control is critical to prevent disproportionation of the anhydride.[1]

### Route C: Coupling Reagents (Discovery Scale)

Utilization of HATU, EDC/HOBt, or T3P.[1]

- Pros: Extremely high yields; tolerance of diverse functional groups.[1]
- Cons: Prohibitively expensive for multi-kilogram scale; difficult removal of urea byproducts (in EDC reactions).

## Detailed Experimental Protocol

Case Study: Synthesis of 4-amino-5-chloro-2-methoxy-N-(1-benzylpiperidin-4-yl)benzamide via Mixed Anhydride Method.

### Reagents & Stoichiometry

Reagent	Equiv.	Role	Criticality
4-Amino-5-chloro-2-methoxybenzoic acid	1.0	Limiting Reagent	Purity >98% required to avoid des-chloro impurities.
Ethyl Chloroformate	1.1	Activator	Excess leads to double acylation.
Triethylamine (TEA)	2.5	Base	Scavenges HCl; drives anhydride formation.
4-Amino-1-benzylpiperidine	1.05	Nucleophile	Small excess ensures complete consumption of activated acid.
Dichloromethane (DCM)	10 Vol	Solvent	Anhydrous (<0.05% water) to prevent anhydride hydrolysis. [1]

## Step-by-Step Methodology

### Step 1: Activation

- Charge 4-amino-5-chloro-2-methoxybenzoic acid (50.0 g) and DCM (500 mL) into a reactor inerted with

- Cool the suspension to 0–5°C. Causality: Low temperature prevents the degradation of the unstable mixed anhydride intermediate.
- Add Triethylamine (60.0 g) dropwise, maintaining internal temperature <10°C. The solution should clarify.
- Add Ethyl Chloroformate (26.0 g) slowly over 30 minutes. Stir at 0–5°C for 1 hour.

### Step 2: Coupling

- Prepare a solution of 4-amino-1-benzylpiperidine (48.0 g) in DCM (100 mL).
- Add the amine solution to the activated acid mixture dropwise at 0–5°C.
- Allow the reaction to warm to 20–25°C and stir for 3 hours.
- In-Process Control (IPC): Monitor by HPLC. Target: <1.0% unreacted acid.

### Step 3: Workup & Purification

- Quench with water (500 mL). Separate phases.
- Wash organic layer with saturated  
(to remove unreacted acid) and brine.
- Dry over  
and concentrate in vacuo.
- Crystallization: Dissolve crude residue in refluxing Ethyl Acetate. Cool slowly to 0°C. Filter the white precipitate.
- Yield: ~85% (Theoretical). Purity: >99.5% (HPLC).

## Process Logic & Impurity Control

Understanding the reaction pathway allows for the prediction and control of specific impurities.

[1]

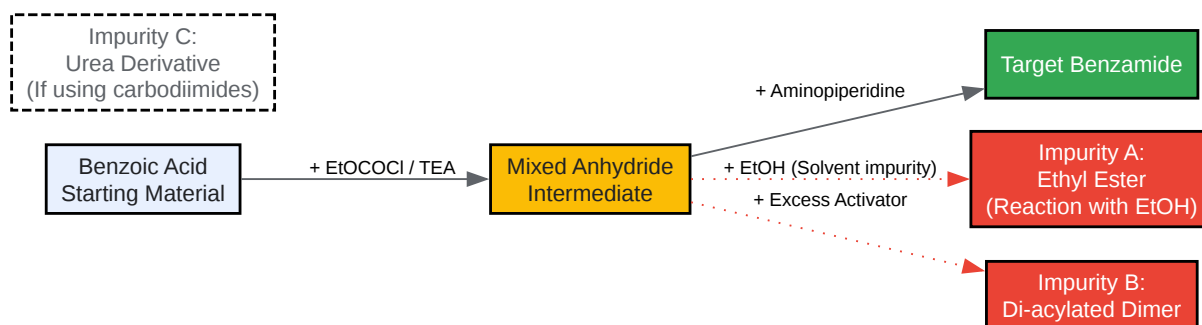

[Click to download full resolution via product page](#)

Figure 2: Reaction pathway and origin of critical impurities.

## Critical Quality Attributes (CQAs)

- Regioisomerism: In the synthesis of the benzoic acid precursor, chlorination of 4-amino-2-methoxybenzoic acid must be strictly controlled to favor the 5-chloro position over the 3-chloro isomer.
- Genotoxic Impurities (GTIs): If alkyl halides (e.g., benzyl chloride) are used in the piperidine synthesis step, trace levels must be quantified (<10 ppm) in the final intermediate.[1]

## References

- Preparation of Prucalopride. Technical Disclosure Commons. (2024). Describes the mixed anhydride coupling of 4-amino-5-chloro-2,3-dihydrobenzofuran-7-carboxylic acid with 1-(3-methoxypropyl)piperidin-4-amine.
- Synthesis and pharmacological evaluation of benzamide derivatives as selective 5-HT<sub>4</sub> receptor agonists. Bioorganic & Medicinal Chemistry. (2005). Details the SAR and synthesis of 4-amino-5-chloro-2-methoxy-N-(piperidin-4-yl)benzamide derivatives.

- Synthesis of 4-Amino-5-chloro-2-methoxy-N-(1-substituted piperidinyl)benzamide (TKS159). Chemical & Pharmaceutical Bulletin. (1999). Provides comparative protocols for benzamide formation using thionyl chloride vs. coupling agents.[1]
- Process for the preparation of Mosapride Citrate. Google Patents (CN111349052B). (2020). Industrial scale synthesis of the 2-ethoxy-4-amino-5-chlorobenzoic acid intermediate.
- Synthesis of N-Substituted Benzamide Derivatives. ResearchGate. (2025). General methodologies for amide bond formation in benzamide antitumor agents.

#### Need Custom Synthesis?

BenchChem offers custom synthesis for rare earth carbides and specific isotopic labeling.

Email: [info@benchchem.com](mailto:info@benchchem.com) or [Request Quote Online](#).

## Sources

- [1. Bot Verification \[rasayanjournal.co.in\]](#)
- [2. prepchem.com \[prepchem.com\]](#)
- [3. CN110143892A - The preparation method of Mosapride intermediate - Google Patents \[patents.google.com\]](#)
- [4. CN111349052B - Synthesis method of mosapride citrate - Google Patents \[patents.google.com\]](#)
- To cite this document: BenchChem. [Advanced Technical Guide: Piperidinyl Benzamide Intermediates in Medicinal Chemistry]. BenchChem, [2026]. [Online PDF]. Available at: [\[https://www.benchchem.com/product/b1524481/docs#advanced-technical-guide-piperidinyl-benzamide-intermediates-in-medicinal-chemistry\]](https://www.benchchem.com/product/b1524481/docs#advanced-technical-guide-piperidinyl-benzamide-intermediates-in-medicinal-chemistry)

#### Disclaimer & Data Validity:

The information provided in this document is for Research Use Only (RUO) and is strictly not intended for diagnostic or therapeutic procedures. While BenchChem strives to provide accurate protocols, we make no warranties, express or implied, regarding the fitness of this product for every specific experimental setup.

**Technical Support:** The protocols provided are for reference purposes. Unsure if this reagent suits your experiment?

**Need Industrial/Bulk Grade?** [Request Custom Synthesis Quote](#)

## BenchChem

Our mission is to be the trusted global source of essential and advanced chemicals, empowering scientists and researchers to drive progress in science and industry.

### Contact

Address: 3281 E Guasti Rd  
Ontario, CA 91761, United States  
Phone: (601) 213-4426  
Email: [info@benchchem.com](mailto:info@benchchem.com)

[Contact our Ph.D. Support Team for a compatibility check](#)