

# Synthesis of Biaryl Pyridines Containing Propynyl Groups: An Application and Protocol Guide

**Author:** BenchChem Technical Support Team. **Date:** May 2026

## Compound of Interest

**Compound Name:** (4-(Prop-1-YN-1-YL)pyridin-2-YL)boronic acid

**Cat. No.:** B15235093

[Get Quote](#)

## Introduction: The Significance of Functionalized Biaryl Pyridines

Biaryl pyridine scaffolds are privileged structures in medicinal chemistry and materials science, forming the core of numerous pharmaceuticals, agrochemicals, and functional organic materials.[1] The unique electronic properties and structural rigidity of the biaryl motif, combined with the hydrogen bonding capacity and coordination ability of the pyridine ring, make these compounds ideal candidates for interacting with biological targets.[2][3] The incorporation of a propynyl group introduces a reactive handle for further functionalization, such as click chemistry, and can enhance binding affinity and metabolic stability. This guide provides a comprehensive overview of the synthetic strategies and detailed protocols for the preparation of biaryl pyridines bearing propynyl substituents, with a focus on palladium-catalyzed cross-coupling reactions.

## Synthetic Strategies: A Mechanistic Perspective

The construction of biaryl pyridines containing propynyl groups typically relies on a sequence of palladium-catalyzed cross-coupling reactions, most notably the Suzuki-Miyaura and Sonogashira reactions. The order of these reactions can be strategically chosen based on the availability of starting materials and the desired substitution pattern on the pyridine ring.

## The Suzuki-Miyaura Coupling: Forging the Biaryl Bond

The Suzuki-Miyaura coupling is a robust and versatile method for the formation of C(sp<sup>2</sup>)-C(sp<sup>2</sup>) bonds, making it the cornerstone for synthesizing biaryl systems.[4][5] The reaction involves the coupling of an aryl or heteroaryl halide with an organoboron reagent, typically a boronic acid or its ester, in the presence of a palladium catalyst and a base.

The choice of catalyst, ligand, and base is crucial for achieving high yields, particularly when dealing with the electron-deficient pyridine ring. Palladium(II) acetate (Pd(OAc)<sub>2</sub>) and tetrakis(triphenylphosphine)palladium(0) (Pd(PPh<sub>3</sub>)<sub>4</sub>) are commonly used catalyst precursors. The ligand plays a critical role in stabilizing the palladium center and facilitating the catalytic cycle.

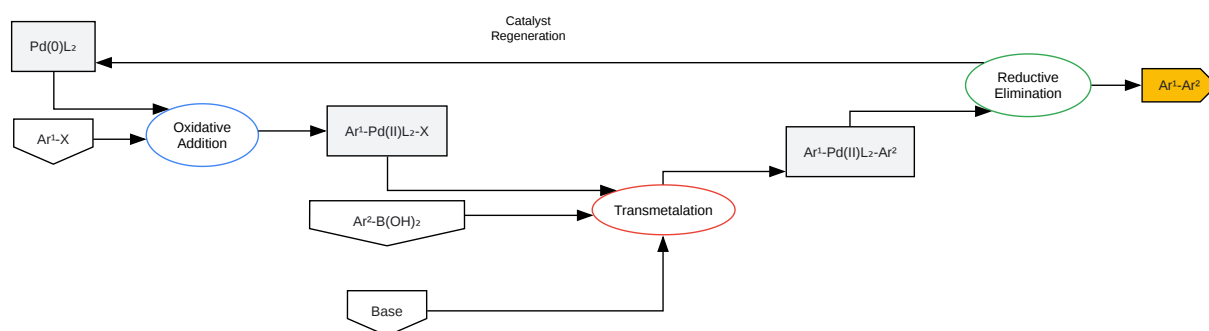

[Click to download full resolution via product page](#)

Figure 1: Catalytic Cycle of the Suzuki-Miyaura Coupling.

## The Sonogashira Coupling: Installing the Propynyl Moiety

The Sonogashira reaction is the method of choice for forming a carbon-carbon bond between a terminal alkyne and an aryl or vinyl halide.<sup>[6][7]</sup> This reaction is typically co-catalyzed by palladium and copper(I) salts. The palladium catalyst facilitates the oxidative addition and reductive elimination steps, while the copper co-catalyst is believed to form a copper(I) acetylide intermediate, which then undergoes transmetalation to the palladium center.<sup>[6][8]</sup>

For the synthesis of the target compounds, a halopyridine or a halo-biaryl pyridine can be coupled with propyne gas or a suitable propyne surrogate.<sup>[2][9][10]</sup> The use of propyne gas requires careful handling due to its volatile and flammable nature.

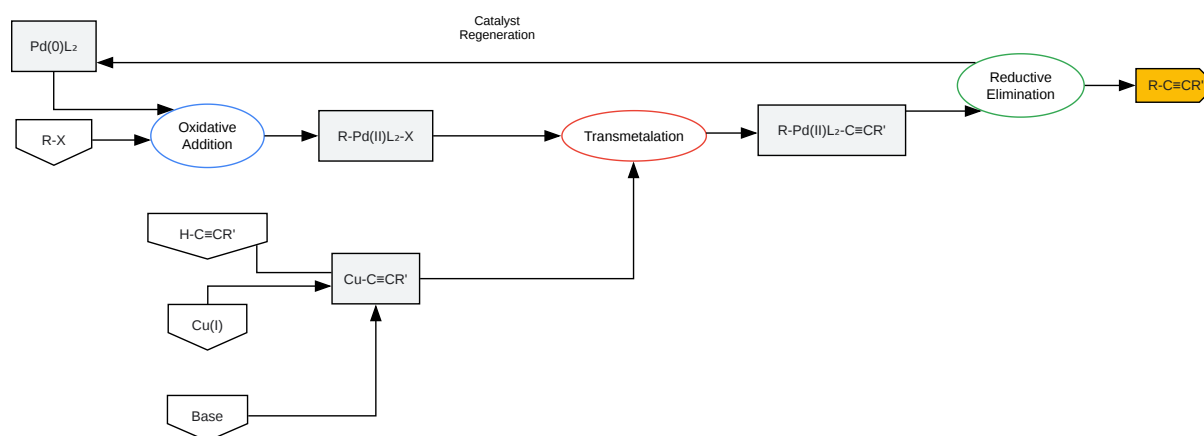

[Click to download full resolution via product page](#)

Figure 2: Catalytic Cycle of the Sonogashira Coupling.

## Synthetic Routes and Experimental Protocols

Two primary synthetic routes are presented for the synthesis of biaryl pyridines containing propynyl groups, starting from a dihalopyridine. The choice of route will depend on the relative reactivity of the halogen atoms and the desired final product.

## Route A: Sonogashira Coupling followed by Suzuki Coupling

This route is advantageous when one halogen is significantly more reactive towards Sonogashira coupling (e.g., I > Br > Cl).

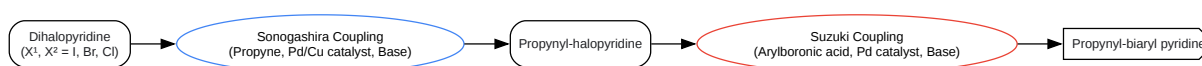

[Click to download full resolution via product page](#)

Figure 3: Synthetic pathway for Route A.

### Protocol A1: Sonogashira Coupling of 2,5-Dibromopyridine with Propyne

- Materials and Reagents:
  - 2,5-Dibromopyridine
  - Propyne (as a solution in THF or generated in situ)
  - Bis(triphenylphosphine)palladium(II) dichloride (Pd(PPh<sub>3</sub>)<sub>2</sub>Cl<sub>2</sub>)
  - Copper(I) iodide (CuI)
  - Triethylamine (Et<sub>3</sub>N)
  - Anhydrous tetrahydrofuran (THF)
- Procedure:
  - To a flame-dried Schlenk flask under an inert atmosphere (argon or nitrogen), add 2,5-dibromopyridine (1.0 eq), Pd(PPh<sub>3</sub>)<sub>2</sub>Cl<sub>2</sub> (0.03 eq), and CuI (0.05 eq).

- Add anhydrous THF and triethylamine (2.0 eq).
- Cool the mixture to 0 °C and slowly bubble propyne gas through the solution for 15 minutes, or add a solution of propyne in THF (1.2 eq).
- Allow the reaction to warm to room temperature and stir for 12-16 hours.
- Monitor the reaction progress by thin-layer chromatography (TLC) or gas chromatography-mass spectrometry (GC-MS).
- Upon completion, quench the reaction with saturated aqueous ammonium chloride solution.
- Extract the product with ethyl acetate, wash the combined organic layers with brine, dry over anhydrous sodium sulfate, and concentrate under reduced pressure.
- Purify the crude product by column chromatography on silica gel to afford 5-bromo-2-(prop-1-yn-1-yl)pyridine.

#### Protocol A2: Suzuki Coupling of 5-Bromo-2-(prop-1-yn-1-yl)pyridine with Phenylboronic Acid

- Materials and Reagents:
  - 5-Bromo-2-(prop-1-yn-1-yl)pyridine
  - Phenylboronic acid
  - Tetrakis(triphenylphosphine)palladium(0) ( $\text{Pd}(\text{PPh}_3)_4$ )
  - Potassium carbonate ( $\text{K}_2\text{CO}_3$ )
  - 1,4-Dioxane
  - Water
- Procedure:

- To a round-bottom flask, add 5-bromo-2-(prop-1-yn-1-yl)pyridine (1.0 eq), phenylboronic acid (1.2 eq), Pd(PPh<sub>3</sub>)<sub>4</sub> (0.05 eq), and K<sub>2</sub>CO<sub>3</sub> (2.0 eq).
- Add a 4:1 mixture of 1,4-dioxane and water.
- Degas the mixture by bubbling argon through the solution for 15 minutes.
- Heat the reaction mixture to 90 °C and stir for 8-12 hours.
- Monitor the reaction progress by TLC or LC-MS.
- After completion, cool the reaction to room temperature and dilute with water.
- Extract the product with ethyl acetate, wash the combined organic layers with brine, dry over anhydrous sodium sulfate, and concentrate under reduced pressure.
- Purify the crude product by column chromatography on silica gel to yield 5-phenyl-2-(prop-1-yn-1-yl)pyridine.

## Route B: Suzuki Coupling followed by Sonogashira Coupling

This approach is useful when the reactivity of the halogens towards Suzuki coupling is more distinct, allowing for selective initial arylation.

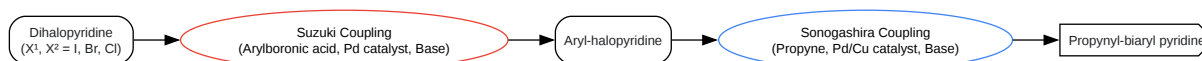

[Click to download full resolution via product page](#)

Figure 4: Synthetic pathway for Route B.

### Protocol B1: Suzuki Coupling of 2,5-Dibromopyridine with Phenylboronic Acid

- Materials and Reagents:
  - 2,5-Dibromopyridine

- Phenylboronic acid
- Palladium(II) acetate ( $\text{Pd}(\text{OAc})_2$ )
- 2-Dicyclohexylphosphino-2',6'-dimethoxybiphenyl (SPhos)
- Potassium phosphate ( $\text{K}_3\text{PO}_4$ )
- Toluene
- Water
- Procedure:
  - In a Schlenk tube, combine 2,5-dibromopyridine (1.0 eq), phenylboronic acid (1.1 eq),  $\text{Pd}(\text{OAc})_2$  (0.02 eq), SPhos (0.04 eq), and  $\text{K}_3\text{PO}_4$  (2.0 eq).
  - Evacuate and backfill the tube with argon three times.
  - Add degassed toluene and water (10:1 mixture).
  - Heat the reaction mixture to 100 °C for 16 hours.
  - Monitor the reaction by GC-MS.
  - Upon completion, cool the reaction to room temperature, dilute with ethyl acetate, and filter through a pad of Celite.
  - Wash the filtrate with water and brine, dry over anhydrous sodium sulfate, and concentrate in vacuo.
  - Purify by column chromatography to isolate 5-bromo-2-phenylpyridine.

#### Protocol B2: Sonogashira Coupling of 5-Bromo-2-phenylpyridine with Propyne

- Materials and Reagents:
  - 5-Bromo-2-phenylpyridine

- Propyne (as a solution in THF or generated in situ)
- Bis(triphenylphosphine)palladium(II) dichloride ( $\text{Pd}(\text{PPh}_3)_2\text{Cl}_2$ )
- Copper(I) iodide ( $\text{CuI}$ )
- Diisopropylethylamine (DIPEA)
- Anhydrous N,N-dimethylformamide (DMF)
- Procedure:
  - To a flame-dried flask under argon, add 5-bromo-2-phenylpyridine (1.0 eq),  $\text{Pd}(\text{PPh}_3)_2\text{Cl}_2$  (0.04 eq), and  $\text{CuI}$  (0.08 eq).
  - Add anhydrous DMF and DIPEA (2.5 eq).
  - Introduce propyne via bubbling or as a THF solution (1.5 eq) at room temperature.
  - Stir the reaction at 60 °C for 6 hours.
  - Monitor the reaction by LC-MS.
  - After completion, cool to room temperature and pour into water.
  - Extract with diethyl ether, wash the combined organic layers with brine, dry over magnesium sulfate, and concentrate.
  - Purify by flash chromatography to obtain 5-phenyl-2-(prop-1-yn-1-yl)pyridine.

## Data Presentation: A Comparative Overview

Route	Intermediate	Intermediate Yield (%)	Final Product	Final Yield (%)	Key Considerations
A	5-Bromo-2-(prop-1-yn-1-yl)pyridine	75-85	5-Phenyl-2-(prop-1-yn-1-yl)pyridine	80-90	Selective Sonogashira on more reactive halide.
B	5-Bromo-2-phenylpyridine	80-90	5-Phenyl-2-(prop-1-yn-1-yl)pyridine	70-80	Selective Suzuki on more reactive halide.

## Characterization of the Final Product: 5-Phenyl-2-(prop-1-yn-1-yl)pyridine

The structure of the synthesized biaryl pyridine containing a propynyl group should be confirmed by standard analytical techniques.

- $^1\text{H}$  NMR (400 MHz,  $\text{CDCl}_3$ ):** The proton NMR spectrum is expected to show signals for the pyridine and phenyl protons in the aromatic region ( $\delta$  7.0-9.0 ppm). A characteristic singlet for the methyl protons of the propynyl group should appear in the upfield region ( $\delta$  ~2.1 ppm).
- $^{13}\text{C}$  NMR (100 MHz,  $\text{CDCl}_3$ ):** The carbon NMR spectrum will display signals for the aromatic carbons of both rings, as well as the two sp-hybridized carbons of the alkyne and the methyl carbon of the propynyl group.
- High-Resolution Mass Spectrometry (HRMS):** HRMS analysis will confirm the molecular formula of the product by providing a highly accurate mass-to-charge ratio.

## Conclusion and Future Perspectives

The sequential application of Sonogashira and Suzuki cross-coupling reactions provides a reliable and versatile platform for the synthesis of biaryl pyridines functionalized with propynyl

groups. The choice of the synthetic route can be tailored based on the starting materials and desired substitution pattern. These compounds serve as valuable building blocks for the development of novel pharmaceuticals and functional materials, with the propynyl group offering a gateway for further molecular diversification.

## References

- Recent Advances in Pyridine Scaffold: Focus on Chemistry, Synthesis, and Antibacterial Activities. (2023). PMC. [\[Link\]](#)
- Sonogashira Coupling. NROChemistry. [\[Link\]](#)
- Sonogashira Coupling. Organic Chemistry Portal. [\[Link\]](#)
- A Convenient Procedure for Sonogashira Reactions Using Propyne. (2021). Semantic Scholar. [\[Link\]](#)
- A Convenient Procedure for Sonogashira Reactions Using Propyne. (2022). Thieme. [\[Link\]](#)
- A Convenient Procedure for Sonogashira Reactions Using Propyne. ResearchGate. [\[Link\]](#)
- The Suzuki coupling reaction of arylbromides with phenylboronic acid. ResearchGate. [\[Link\]](#)
- Suzuki reactions of 2-bromopyridine with aryl boronic acids a. ResearchGate. [\[Link\]](#)
- Suzuki cross-coupling of aryl bromides with phenylboronic acid. ResearchGate. [\[Link\]](#)
- Design, synthesis and evaluation of 2-phenylpyrimidine derivatives as novel antifungal agents targeting CYP51. PMC. [\[Link\]](#)
- An Operationally Simple Sonogashira Reaction for an Undergraduate Organic Chemistry Laboratory Class. Pendidikan Kimia. [\[Link\]](#)
- The Suzuki-Miyaura Reaction of Phenylboronic Acid with Different Aryl Halides Catalyzed with Cu (II) Salen Complex@KCC-1 as a Recyclable Heterogeneous Catalyst. Journal of Nanostructures. [\[Link\]](#)

- A Complete  $^1\text{H}$  and  $^{13}\text{C}$  NMR Data Assignment for Three 3-[Substituted methylidene]-1H,3H-naphtho-[1,8-cd]-pyran-1-ones. MDPI. [\[Link\]](#)
- Design and synthesis of 2-phenylimidazo[1,2-a]pyridines as a novel class of melatonin receptor ligands. ResearchGate. [\[Link\]](#)
- Palladium-Catalyzed Sonogashira Coupling Reaction of 2-Amino-3-Bromopyridines with Terminal Alkynes. Scientific Research Publishing. [\[Link\]](#)
- Characterization of Biaryl Torsional Energetics and its Treatment in OPLS All-Atom Force Fields. PMC. [\[Link\]](#)

### Need Custom Synthesis?

BenchChem offers custom synthesis for rare earth carbides and specific isotopic labeling.

Email: [info@benchchem.com](mailto:info@benchchem.com) or [Request Quote Online](#).

## Sources

1. Sonogashira cross-coupling reactions of 3,5-dibromo-2,6-dichloropyridine - Organic & Biomolecular Chemistry (RSC Publishing) [[pubs.rsc.org](https://pubs.rsc.org)]
2. A Convenient Procedure for Sonogashira Reactions Using Propyne [[organic-chemistry.org](https://organic-chemistry.org)]
3. [researchgate.net](https://researchgate.net) [[researchgate.net](https://researchgate.net)]
4. [researchgate.net](https://researchgate.net) [[researchgate.net](https://researchgate.net)]
5. The Suzuki-Miyaura Reaction of Phenylboronic Acid with Different Aryl Halides Catalyzed with Cu (II) Salen Complex@KCC-1 as a Recyclable Heterogeneous Catalyst [[jns.kashanu.ac.ir](https://jns.kashanu.ac.ir)]
6. Sonogashira Coupling | NROChemistry [[nrochemistry.com](https://nrochemistry.com)]
7. Sonogashira Coupling [[organic-chemistry.org](https://organic-chemistry.org)]
8. Palladium-Catalyzed Sonogashira Coupling Reaction of 2-Amino-3-Bromopyridines with Terminal Alkynes [[scirp.org](https://scirp.org)]
9. [semanticscholar.org](https://semanticscholar.org) [[semanticscholar.org](https://semanticscholar.org)]
10. [researchgate.net](https://researchgate.net) [[researchgate.net](https://researchgate.net)]

- To cite this document: BenchChem. [Synthesis of Biaryl Pyridines Containing Propynyl Groups: An Application and Protocol Guide]. BenchChem, [2026]. [Online PDF]. Available at: [<https://www.benchchem.com/product/b15235093/docs#synthesis-of-biaryl-pyridines-containing-propynyl-groups-an-application-and-protocol-guide>]

---

### Disclaimer & Data Validity:

The information provided in this document is for Research Use Only (RUO) and is strictly not intended for diagnostic or therapeutic procedures. While BenchChem strives to provide accurate protocols, we make no warranties, express or implied, regarding the fitness of this product for every specific experimental setup.

**Technical Support:** The protocols provided are for reference purposes. Unsure if this reagent suits your experiment?

**Need Industrial/Bulk Grade?** [Request Custom Synthesis Quote](#)

## BenchChem

Our mission is to be the trusted global source of essential and advanced chemicals, empowering scientists and researchers to drive progress in science and industry.

### Contact

Address: 3281 E Guasti Rd  
Ontario, CA 91761, United States  
Phone: (601) 213-4426  
Email: [info@benchchem.com](mailto:info@benchchem.com)

[Contact our Ph.D. Support Team for a compatibility check](#)