

Technical Support Center: Mono-Cbz Protection of Guanidines

Author: BenchChem Technical Support Team. **Date:** May 2026

Compound of Interest

Compound Name: *N*-Cbz-*a*-(methylamino)-
benzeneacetic acid

Cat. No.: B15233663

[Get Quote](#)

Topic: Improving Efficiency and Selectivity in Mono-Benzylloxycarbonyl (Cbz) Protection of Guanidines. Audience: Medicinal Chemists, Process Chemists, and Drug Discovery Researchers.^{[1][2]} Format: Interactive Troubleshooting & Optimization Guide.

The Core Challenge: The "pKa Trap"

Q: Why is my reaction constantly yielding bis-Cbz product or recovering starting material, with very little mono-Cbz?

A: You are likely falling into the pKa Trap.^{[1][2]} This is the fundamental thermodynamic barrier in direct guanidine protection.^{[1][2]}

- The Starting Material (SM): Alkyl guanidines are highly basic (ngcontent-ng-c1352109670="" _ngghost-ng-c1270319359="" class="inline ng-star-inserted">

).^[1] In standard basic conditions (pH 10–12), a significant portion remains protonated (guanidinium cation) and non-nucleophilic.^{[1][2]}

- The Product (Mono-Cbz): The electron-withdrawing Cbz group lowers the basicity of the guanidine significantly (ngcontent-ng-c1352109670="" _ngghost-ng-c1270319359="" class="inline ng-star-inserted">).^[1]
- The Trap: At a reaction pH of 10, the SM is largely protonated (inactive), while the Mono-Cbz product is largely deprotonated (neutral and active).^{[1][2]} Even though the Cbz group electronically deactivates the nitrogen, the concentration of the active neutral species is much higher for the product than for the starting material.^{[1][2]} The electrophile (Cbz-Cl) preferentially attacks the neutral Mono-Cbz species, leading to bis-protection.^{[1][2]}

Visualizing the Mechanism

The following diagram illustrates the kinetic competition driven by pH states.

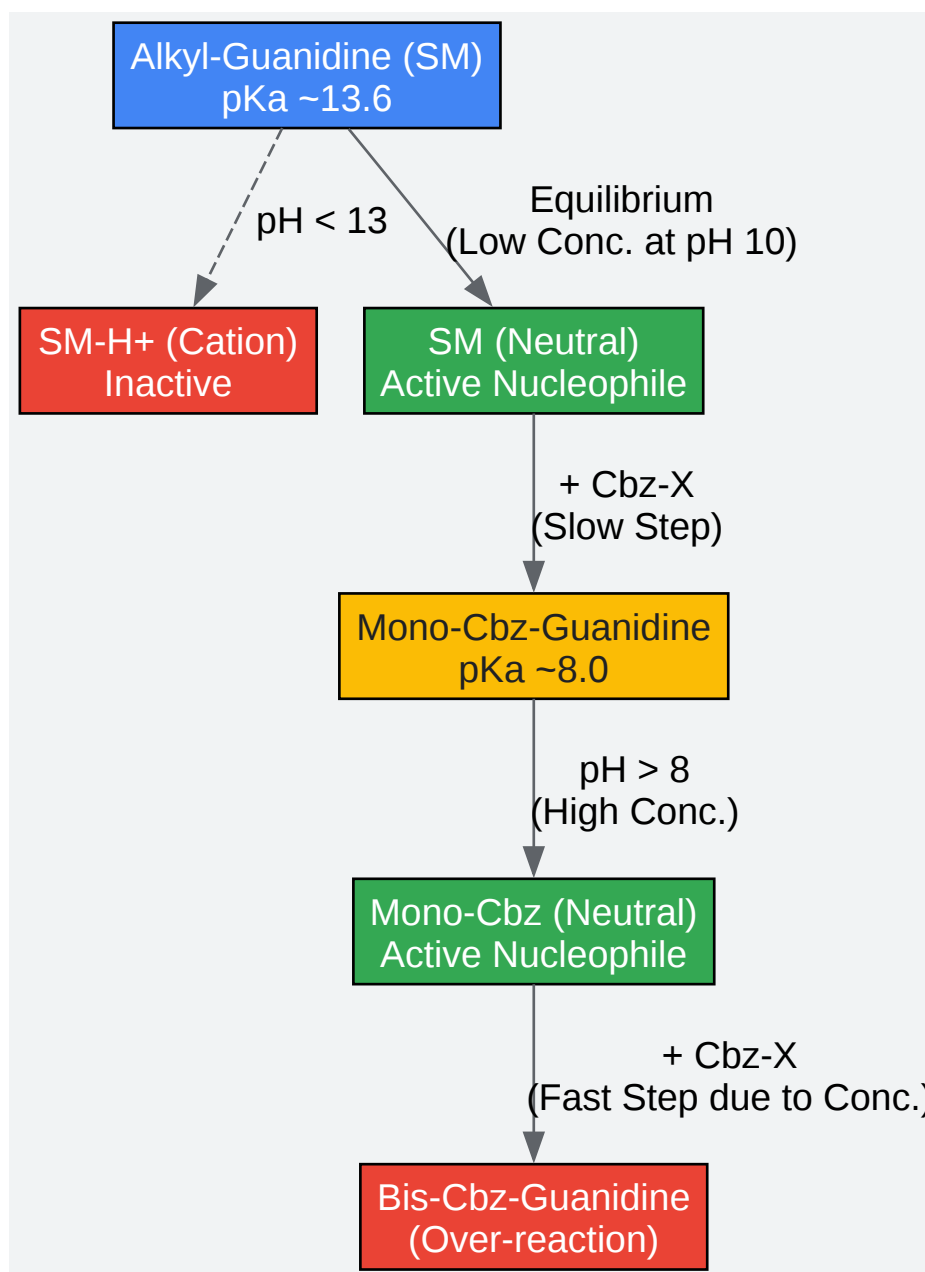

[Click to download full resolution via product page](#)

Figure 1: The pKa Trap. At standard reaction pH, the product is more available in its reactive neutral form than the starting material, promoting over-reaction.[1][2]

Reagent Selection & Protocol Optimization

Q: Should I use Cbz-Cl or Cbz-OSu?

A: For mono-protection, Cbz-OSu (N-(Benzyloxycarbonyloxy)succinimide) is superior.[1][2]

Feature	Cbz-Cl (Benzyl Chloroformate)	Cbz-OSu (Succinimide Carbonate)
Reactivity	High (Aggressive)	Moderate (Tunable)
Selectivity	Poor (Prone to Bis-Cbz)	High (Favors Mono-Cbz)
Byproducts	HCl (Requires strong base buffering)	N-Hydroxysuccinimide (Neutral/Weakly acidic)
Recommendation	Use for Bis-protection or robust substrates.[1][2]	Standard for Mono-protection.

Protocol A: The "Golden Standard" (Cbz-OSu Method)

Best for: Valuable substrates requiring high mono-selectivity.[1]

Reagents:

- Substrate: Alkyl Guanidine (1.0 equiv)[1][2]
- Reagent: Cbz-OSu (0.95 - 1.0 equiv) — Slight deficit prevents over-reaction.[1][2]
- Base: DIPEA (N,N-Diisopropylethylamine) (1.5 equiv)[1]
- Solvent: DCM (Dichloromethane) or DMF (if solubility is poor).[1][2]

Step-by-Step:

- Dissolution: Dissolve guanidine substrate in DCM (0.1 M). Add DIPEA.
- Addition: Add Cbz-OSu as a solid in one portion (or dissolved in minimal DCM) at 0°C.
- Reaction: Stir at 0°C for 1 hour, then warm to Room Temperature (RT) for 12–18 hours.
- Workup (Critical):
 - Wash organic layer with 5% Citric Acid (aq).[1][2]

- Why? The Mono-Cbz product (pKa ~8) will remain in the organic layer (mostly neutral at pH 2-3 of citric acid wash? Correction: At pH 2, Mono-Cbz is protonated and may go to water.[1][2] See Note below.).
- Refined Workup: Wash with water and brine.[1][2] If the product is amphiphilic, evaporate solvent and purify via flash chromatography (DCM/MeOH gradient).[1][2]
- Purification: Mono-Cbz guanidines often streak on silica.[1][2] Add 1% Triethylamine (TEA) to your eluent.[1][2]

Protocol B: The "Bis-then-Clip" Strategy (Maki Method)

Best for: Cases where Mono-protection fails, and you constantly get mixtures.[1][2]

Instead of fighting the kinetics, drive the reaction to completion (Bis-Cbz) and then selectively remove one group.[1][2]

- Bis-Protection: React Guanidine with 3.0 equiv Cbz-Cl and 4.0 equiv NaOH (Schotten-Baumann conditions) to force Bis-Cbz formation.[2]
- Selective Deprotection:
 - Dissolve Bis-Cbz guanidine in MeOH.
 - Add catalyst: Pd(OAc)₂ (5 mol %).[1][2]
 - Stir under H₂ (balloon) or transfer hydrogenation conditions.
 - Mechanism:[2][3][4][5] The steric bulk of the Bis-Cbz species makes one group more accessible/labile than the Mono-species under controlled catalytic conditions [1].[1]

Troubleshooting Guide

Q: My product is stuck in the aqueous layer during workup.

- Cause: Mono-Cbz guanidines are still basic (pKa ~8) and polar.[1][2] In acidic washes (HCl), they protonate and become water-soluble salts.[1][2]

- Fix:
 - Use a neutral workup (Water/Brine only).[\[1\]](#)[\[2\]](#)
 - If you must remove starting material, use a buffer at pH 9.0.[\[1\]](#)[\[2\]](#) At pH 9, the SM (pKa 13) is protonated (water soluble), but the Mono-Cbz (pKa ~8) is largely neutral (organic soluble).[\[1\]](#)[\[2\]](#)

Q: I am seeing regioselectivity issues (N vs. N').

- Context: If your guanidine is monosubstituted (ngcontent-ng-c1352109670="" _ngghost-ng-c1270319359="" class="inline ng-star-inserted">
) , Cbz can attach to the substituted nitrogen (
) or the unsubstituted nitrogen (
).[\[1\]](#)
- Insight: Cbz-Cl/OSu generally prefers the less sterically hindered nitrogen (the ngcontent-ng-c1352109670="" _ngghost-ng-c1270319359="" class="inline ng-star-inserted">
terminus).[\[1\]](#)
- Fix: If you need the Cbz on the internal nitrogen, you cannot use direct protection.[\[1\]](#)[\[2\]](#) You must synthesize the guanidine de novo using a protected guanylation agent like N,N'-Bis(Cbz)-1H-pyrazole-1-carboximidine [\[2\]](#).[\[1\]](#)[\[2\]](#)

Q: The reaction yields 50% SM and 50% Bis-Cbz, with no Mono.

- Diagnosis: This is the classic "Phase Transfer" failure.[\[1\]](#)[\[2\]](#) The reaction is happening too fast at the interface or in solution where local pH is too high.[\[1\]](#)[\[2\]](#)
- Fix: Switch to Protocol A (Homogeneous organic phase with Cbz-OSu). If you must use Cbz-Cl, use a biphasic system (DCM/Water) with highly efficient stirring and slow addition of Cbz-Cl over 1 hour.[\[1\]](#)[\[2\]](#)

Decision Matrix (Workflow)

Follow this logic flow to select the correct experimental path.

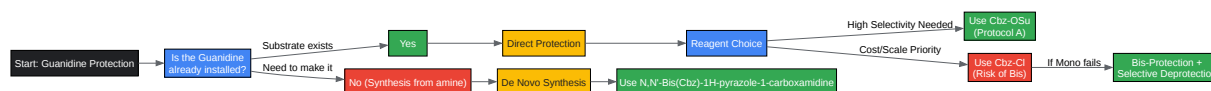

[Click to download full resolution via product page](#)

Figure 2: Strategic Decision Matrix for Guanidine Protection.[1][2]

References

- Maki, T.; Tsuritani, T.; Yasukata, T. Selective Deprotection of N,N'-Bis(benzyloxycarbonyl)guanidines. *Org. Lett.* 2014, 16, 1868–1871. [1][2][6][7] [Link]
- Bernatowicz, M. S.; Wu, Y.; Matsueda, G. R. 1H-Pyrazole-1-carboxamide Hydrochloride: An Attractive Reagent for Guanylation of Amines and Its Application to Peptide Synthesis. *J. Org. Chem.* 1992, 57, 2497–2502. [1][2] [Link][1][2]
- Greene, T. W.; Wuts, P. G. M. [1][2] *Protective Groups in Organic Synthesis*, 4th ed.; Wiley-Interscience: New York, 2006. [1][2]
- Powell, D. A.; Ramsden, P. D.; Batey, R. A. [1][2] Phase-Transfer-Catalyzed Alkylation of Guanidines. *J. Org. Chem.* 2003, 68, 2300–2309. [1][2] [Link]

Need Custom Synthesis?

BenchChem offers custom synthesis for rare earth carbides and specific isotopic labeling.

Email: info@benchchem.com or [Request Quote Online](#).

Sources

- 1. Preparation of Mono-Cbz Protected Guanidines - PMC [pmc.ncbi.nlm.nih.gov]

- [2. Guanidine - Wikipedia \[en.wikipedia.org\]](#)
- [3. Cbz Protection - Common Conditions \[commonorganicchemistry.com\]](#)
- [4. masterorganicchemistry.com \[masterorganicchemistry.com\]](#)
- [5. Amino protecting group—benzyloxycarbonyl \(Cbz\) \[en.highfine.com\]](#)
- [6. Cbz-Protected Amino Groups \[organic-chemistry.org\]](#)
- [7. glaserr.missouri.edu \[glaserr.missouri.edu\]](#)
- To cite this document: BenchChem. [Technical Support Center: Mono-Cbz Protection of Guanidines]. BenchChem, [2026]. [Online PDF]. Available at: [\[https://www.benchchem.com/product/b15233663/docs#technical-support-center-mono-cbz-protection-of-guanidines\]](https://www.benchchem.com/product/b15233663/docs#technical-support-center-mono-cbz-protection-of-guanidines)

Disclaimer & Data Validity:

The information provided in this document is for Research Use Only (RUO) and is strictly not intended for diagnostic or therapeutic procedures. While BenchChem strives to provide accurate protocols, we make no warranties, express or implied, regarding the fitness of this product for every specific experimental setup.

Technical Support: The protocols provided are for reference purposes. Unsure if this reagent suits your experiment?

Need Industrial/Bulk Grade? [Request Custom Synthesis Quote](#)

BenchChem

Our mission is to be the trusted global source of essential and advanced chemicals, empowering scientists and researchers to drive progress in science and industry.

Contact

Address: 3281 E Guasti Rd

Ontario, CA 91761, United States

Phone: (601) 213-4426

Email: info@benchchem.com

Contact our Ph.D. Support Team for a compatibility check